

# Amerigear® Mill Spindles

## Heavy Duty, High Performance Design

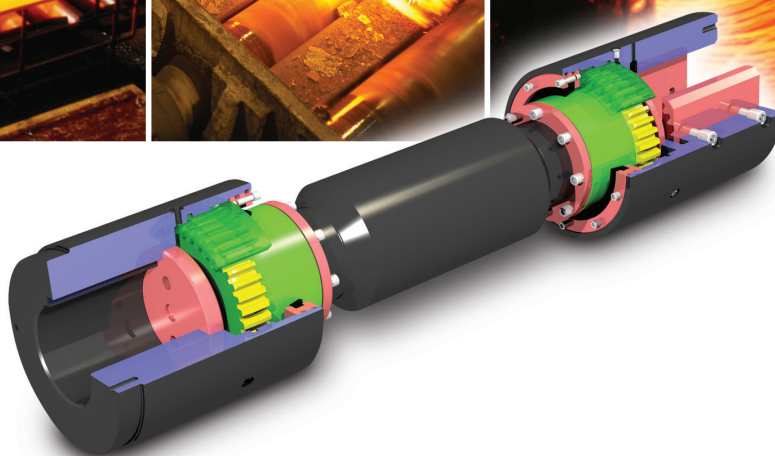

 **Ameridrives®**  
Couplings

An Altra Industrial Motion Company

# Flexible Spindles

Gear type spindles have been universally accepted on all types of mill drives since their commercial development in the early 1950s. Rolling mill couplings that connect the drives to the rolls were often taken for granted. However, market demand for greater productivity and improved quality of rolled products has driven the design and manufacture of equipment to accommodate high operating speeds, torques and misalignments with minimum maintenance. Gear spindles were originally introduced to meet these needs by replacing inefficient universal slippers and cast wobblers.

The worldwide metals industry, from large integrated plants to small rolling facilities, is becoming more efficient and effective in producing quality products at economical prices. A wide variety of new process developments have been implemented in the industry to achieve metal production efficiencies. These developments include new machine design concepts, better metallurgical practices, as well as the application of process control and automation. Consequently, modern rolling mills have become a very complex and sophisticated system of electronic, hydraulic, and mechanical components.

Gear spindles are a critical component of the drive train. Strip quality and thickness control can be influenced by the performance of the drive spindles. Ameridrives is continually improving gear spindle technology, quality, and operating efficiency necessary to meet the demands of the most up-to-date mill equipment.

The modern, efficient gear type spindle requires less maintenance and is much more economical than its predecessors. Gear spindles provide constant angular velocity at misalignment angles, which ensures even transmission of power.

This results in uniform size and improved surface quality of rolled products. Drives that operate at a non-uniform angular velocity may cause product size variations and surface finish irregularities. In addition, the inherent dynamic balance characteristics of gear type flexible spindles minimize vibration, thus increasing the operating life of bearings, gears, and other components of the drive train.

## Table Of Contents

Introduction .....	2
Fully-Crowned Advanced Teeth Design .....	3-4
Materials and Heat Treatment .....	5
<b>SM Spindle (Mill Type)</b>	
SM Design 1 Engineering Data .....	6
SM Design 2 Engineering Data .....	7
SM Design 3 Engineering Data .....	8
SM Design 4 Engineering Data .....	9
SM Design Features .....	10-11
Maintenance and Lubrication .....	12
<b>SL (Leveler) and SF (Flange) Spindles</b>	
Selection .....	13
SL Engineering Data .....	14
SF Engineering Data .....	15
Variations and Custom Applications .....	16-17
Typical Applications .....	18
Rolling Mill Application Data Form.....	19



There are four basic types of Amerigear Spindles: VL Mill Spindle (our newest design), SM Mill Type, SL Leveler Type and SF Flange Type. **The new VL Mill Spindle is used on medium to heavy duty metals rolling main drives and auxiliary equipment. VL Mill Spindles are specifically designed to meet the needs of hot and cold rolling mill applications at reduced cost. For more information, request catalog 781-ADV.** The SM Spindle is custom designed and is used primarily on rolling mill drives ranging from heavy duty, hot reversing roughers to high speed cold mills. The spindles used on these drives are often limited by the minimum roll size, and they must handle high continuous loads. These spindles must also accommodate high misalignment angles due to the constant change in material thickness, roll size, and roll change requirements. The SL and SF Spindles are standard designs used mainly on auxiliary equipment.

Each Amerigear mill spindle is custom designed for a particular application. Torque application factors (TAF) are considered. Gear spindle materials, heat treatment and hardening processes, misalignment capabilities, optional design features and custom modifications are reviewed in our application analysis to ensure maximum service life with minimum downtime. Finite element analysis (FEA) techniques are used to develop gear tooth geometries that maximize strength and contact area.

In addition to special designs and materials, regular preventive maintenance and ongoing corrective action is necessary for maximum performance from your gear type flexible spindles. Ameridrives is a leader in providing contract maintenance programs as well as specific maintenance training which covers all aspects of lubrication and repair.

# Fully-Crowned Advanced Gear Design

## Fully Crowned Teeth

The Ameridrives Fully-Crowned Tooth represents the ultimate achievement in the art of gear tooth design, with all three working portions of the tooth crowned.

### A. Crowned Flank

- Thickness greatest at center of tooth
- Larger contact area per tooth
- More teeth in contact for given angle
- Actual loading at center of tooth
- Eliminates end loading
- Optimum load distribution
- Minimum backlash
- Constant velocity
- Optimum oil film characteristics

### B. Crowned Tips

- Creates ball and socket action
- Minimum diametral sleeve clearance
- Optimum dynamic balance characteristics

### C. Crowned Chamfer

- Eliminates interference with internal tooth fillets
- Allows for true involute flanks
- Freedom to misalign

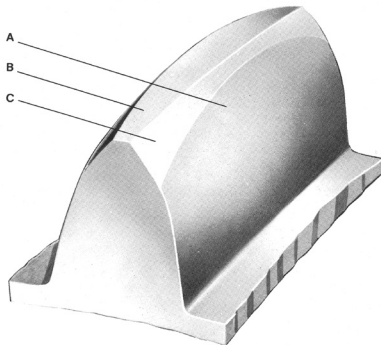

## Improving on the Existing Design

Through an intense "Advanced Gear Design" analysis (patent pending), Ameridrives Couplings has managed to optimize the geometry of the existing Fully-Crowned Gear Tooth design to increase capacities up to 300% greater than previous designs. This analysis was developed through years of finite element analysis, strain gage testing, dynamic testing and field testimonials from users.

## The Basics of "Advanced Gear Design"

The main concept of the Advanced Gear Design is optimization of the tooth geometry to obtain a higher percent of teeth in contact at the coupling operating conditions. In order to perform this optimization, you must first understand the variables that affect the actual percent of teeth in contact. These are:

### Misalignment Angle

- This is the only consideration in a conventional gear coupling analysis.
- Theoretically, there are only two teeth in contact when any misalignment is present and no load is applied. The remainder has a gap between each tooth set.

### Applied Load

- There must be a load applied to obtain contact of more than two teeth.

### Flank Curvature

- This is the main contributor aside from the misalignment angle in determining the gap between each tooth set.

- An optimized flank curvature will produce minimal gaps between each tooth set while maintaining an acceptable compressive stress.

### Hub and Sleeve Stiffness

- Tooth quantity, tooth size and sleeve barrel diameter are all important factors in determining the stiffness of the hub and sleeve set.
- An optimized stiffness is soft and maintains a balanced deflection of the hub and sleeve set.

## The Development of "Advanced Gear Design" Procedures

The advanced Gear Design procedures were developed using ProENGINEER'S™ 3-D modeling system and NISA finite element software (FEA).

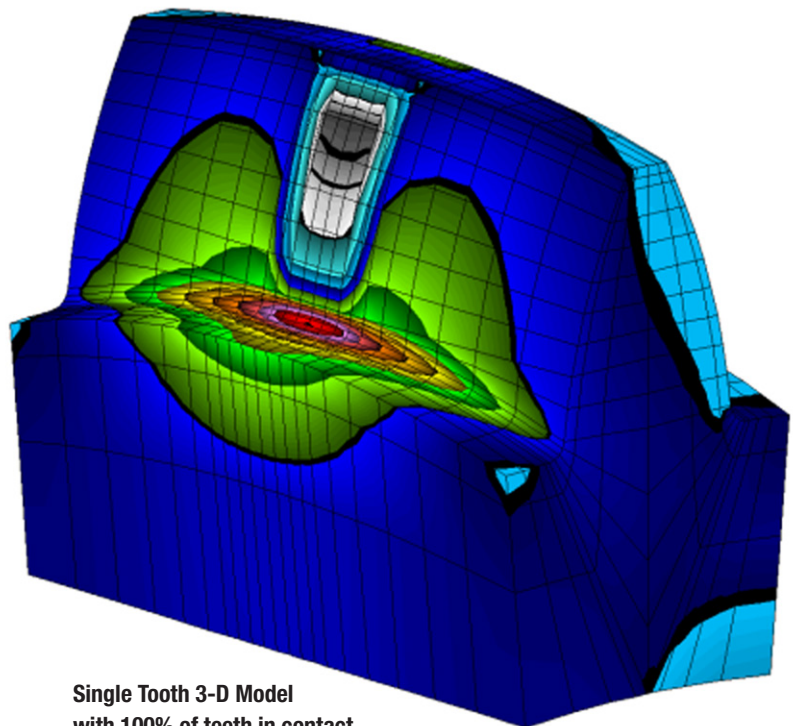

Single Tooth 3-D Model  
with 100% of teeth in contact.

# Fully-Crowned Advanced Gear Design

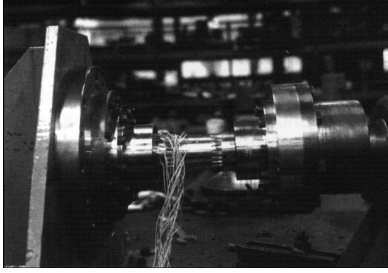

## Verification of the Design Process

- The verification process consisted of numerous in-house strain gage and dynamic tests on both new and old design configurations.
- The correlation of stresses, percent of teeth in contact, and heat generation characteristics were excellent.
- In conjunction with the in-house testing, selected high maintenance, short life mill applications were used for field-testing.
- An optimization process consisting of flank curvature, diametral pitch, face width and sleeve barrel was performed on each configuration.
- The results were outstanding, increasing both load carrying capabilities and coupling life by magnitudes beyond expectations.

## "Percent of Coupling Teeth in Contact" vs. "Percent of Tooth Face in Contact"

- The Percent of Coupling Teeth in Contact is based on the number of teeth in the coupling that transmit load. The more teeth in contact, the higher the torque capacity.
- The Percent of Tooth Face in Contact is the amount of face width that contacts through one revolution. The magnitude of this value is not nearly as important as obtaining a uniform pattern. In fact, to inhibit tooth end loading, the smaller this value, the better. It is limited only by the compressive and wear properties of the material.
- With the knowledge of accurately predicting the percent of coupling teeth in contact, the heart of the Advanced Gear Design, Ameridrives has the ability to design Spindle gearing for the specific operating conditions of each high angle, high torque application.

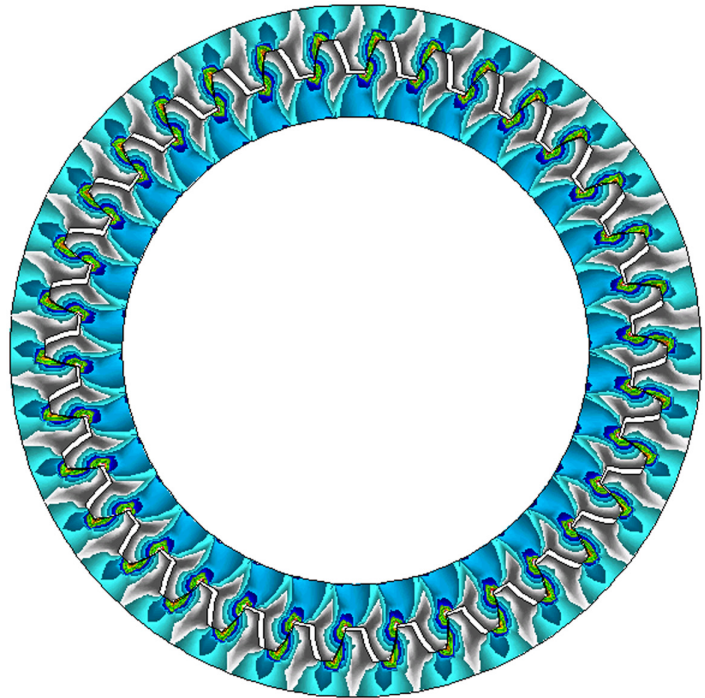

360° 2-D model simulating 100% of teeth in contact

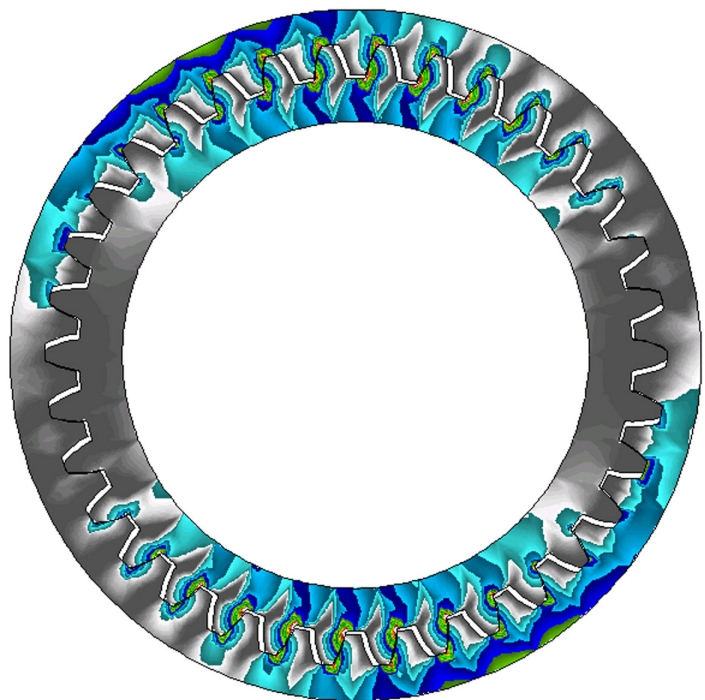

360° 2-D model at angle providing bending stress and percent of teeth in contact

Amerigear Flexible Spindles are used on heavy-duty, high torque applications that require rugged strength such as metal rolling mill main drives and similar heavy equipment. To maximize the torque carrying capacity and life of the spindle, the proper combination of material, heat treatment and gearing geometry must be selected.

Materials used by Ameridrives in the production of spindle components include both medium carbon and forged alloy steels. Various heat treatment methods are also used by Ameridrives to improve the physical and mechanical properties of steel.

Two principle reasons for heat treating spindle parts are to increase strength and to resist wear on working surfaces. However, hardened steel can be brittle or lack fatigue and shock resistance if the material/heat-treat combination is not properly matched. For maximum strength and durability, it is desirable to harden selected outer surfaces of spindle parts while leaving the inner cores ductile for shock resistance.

Several heat treatment methods are available for case hardening the gear tooth components including induction hardening, nitriding and carburizing. Other spindle components may also be heat treated to yield significant improvement in strength and wearability.

The Fully-Contoured Induction Hardened gear, developed by Ameridrives, has been an industry standard for many years and provides excellent torque carrying capacity. Induction hardening imparts a deep, hard case to a gear tooth through localized hardening. It is the most economical choice for case hardening.

Nitriding is a case-hardening process for alloy steel parts that results in exceptionally high surface hardness, good wear resistance, and minimum distortion. It is ideally suited for high speed, high angle spindle applications.

Carburizing is the ultimate means of hardening spindle gear teeth. It is used on the most severe applications requiring optimum spindle design. Select grade alloy forgings are carburized to obtain a very hard deep case while maintaining a tough ductile core. This results in maximum wear characteristics, shock load capability, and torque carrying capacity.

The material and heat treatment combinations commonly used for spindle applications are as follows:

1. AISI 1045 Induction Hardened -The majority of spindles manufactured from this material are the SL and SF types shown on pages 14-15 for use on auxiliary equipment. It is also used for low torque, light duty SM spindles.
2. AISI 4140 Heat Treated and Induction Hardened - This is used on SM medium duty spindle applications such as cold mills, temper mills, and bar mills. Special design SL and SF spindles may also use this combination.
3. AISI 4140 Heat Treated and Nitrided - This is for medium torque, high angle and high speed applications. Nitriding is also preferred for high temperature applications where it is more durable than other forms of hardening.
4. Forged Alloy Steels Heat Treated, Carburized and Lapped - This combination is used for high torque applications such as hot strip mills and reversing roughers where maximum torque transmitting capability is required. The carburizing process imparts a hard, deep case over a ductile and shock resistant core to resist wear and abrasion.

Let Ameridrives review your application and, based upon years of practical experience, provide the correct spindle to satisfy your requirements.

## Exclusive Lapping Process for Optimum Gear Tooth Life

Ameridrives has developed an exclusive lapping process that accurately machine laps the internal and external gear teeth. This process eliminates the effects of minor involute distortion and eccentricity caused by carburizing. Machine lapping also imparts an extremely fine surface finish to the mating teeth and allows for total interchangeability of component parts. As a result, the lapped spindle parts are completely broken in to assure uniform tooth loading.

Other spindle manufacturers remove distortion by grinding or not at all. Grinding is a "hot" process and tends to weaken the hardened surface of the gear as material is removed. Additionally, grinding produces residual tensile stresses or minute cracks on the surface which can be the source of fatigue cracking.

A coupling with ground teeth must still be broken in during initial operation. This may produce burnishing due to remaining tooth spacing errors which can contaminate the lubrication and cause premature galling of the gear teeth.

The net result is lapping generally only removes half as much material as does grinding. Grinding will therefore remove a greater amount of case depth which softens the teeth and reduces spindle wear life. Not removing the distortion by any method requires the teeth to break in during operation. This can produce irreversible damage from unequal tooth loading during break in and contaminate the lubricant and metal particles.

**In accordance with our established policy to constantly improve our products, the specifications contained herein are subject to change without notice.**

# SM (Mill Type) Design 1 | Engineering Data

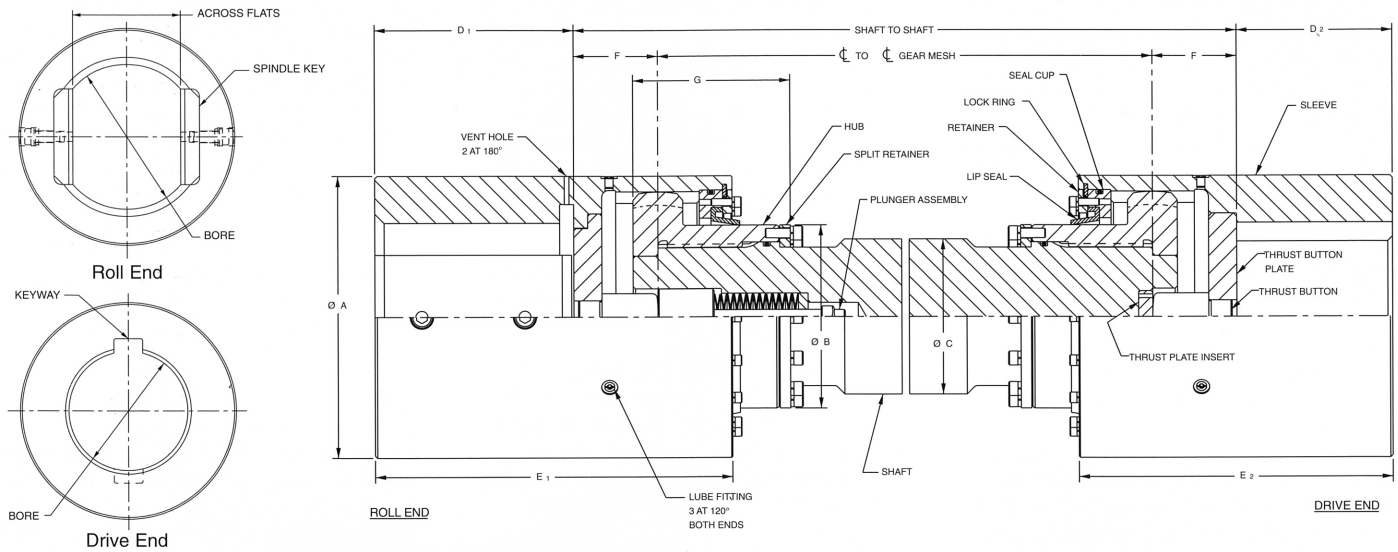

SM Spindles are used on medium to high torque applications which require rugged strength, such as metal rolling mill main drives and similar heavy equipment. Mill type spindles deliver maximum torque capacity under severe shock loads, while operating at relatively high angles.

Gear sections are made from medium carbon and forged alloy steels with heat treated teeth. Hub gear teeth are Fully-Crowned to provide maximum torque capacity with minimum backlash. One-piece, molded lip-type seals, designed for operation under misalignment conditions, provide the most effective closure available to keep lubricant in and contaminants out.

All spindles are designed so that the contact point of the thrust button is located on the centerline of the gear mesh. This provides ball and socket action, rather than the sliding motion that occurs if the contact point is located on the thrust plate.

Size O.D.	Roll End			Drive End				A	B	C	E1	E2	F	G
	Max. Bore	Max. Flats	D1	Max. Bore	Max. Keyway	D2								
6	4.00	3.00	4.00	4.00	1 x 1/2	4.00	6.00	4.12	3.75	7.88	7.88	1.75	4.12	
8	5.38	4.00	5.38	5.38	1-1/4 x 5/8	5.38	8.00	5.62	5.00	10.63	10.63	2.63	5.62	
10	6.63	5.00	6.63	6.63	1-3/4 x 3/4	6.63	10.00	6.38	5.75	13.50	13.50	3.13	6.38	
12	8.00	6.00	8.00	8.00	2 x 3/4	8.00	12.00	7.75	7.00	14.63	14.63	3.25	7.75	
14	9.38	7.00	9.38	9.38	2-1/2 x 7/8	9.38	14.00	9.00	8.13	18.25	18.25	4.06	9.00	
16	10.63	8.00	10.63	10.63	2-1/2 x 7/8	10.63	16.00	11.00	9.88	20.13	20.13	4.38	11.00	
18	12.00	9.00	12.00	12.00	3 x 1	12.00	18.00	12.00	10.75	20.75	20.75	4.38	12.00	
20	13.38	10.00	13.38	13.38	3-1/2 x 1-1/4	13.38	20.00	13.50	12.13	24.38	24.38	5.50	13.50	
22	14.63	11.00	14.63	14.63	3-1/2 x 1-1/4	14.63	22.00	15.75	14.13	25.25	25.25	5.69	15.75	
24	16.00	12.00	16.00	16.00	4 x 1-1/2	16.00	24.00	17.25	15.50	29.13	29.13	6.69	17.25	
26	17.38	13.00	17.38	17.38	4 x 1-1/2	17.38	26.00	18.50	16.63	30.50	30.50	6.69	18.50	
28	18.63	14.00	18.63	18.63	5 x 1-3/4	18.63	28.00	21.00	18.88	33.00	33.00	7.81	21.00	
30	20.00	15.00	20.00	20.00	5 x 1-3/4	20.00	30.00	21.00	18.88	35.63	35.63	8.56	21.00	
32	21.38	16.00	21.38	21.38	5 x 1-3/4	21.38	32.00	24.50	22.00	37.25	37.25	8.69	24.50	
34	22.63	17.00	22.63	22.63	6 x 2	22.63	34.00	25.00	22.50	39.25	39.25	8.69	25.00	
36	24.00	18.00	24.00	24.00	6 x 2	24.00	36.00	25.00	22.50	40.75	40.75	8.75	25.00	
38	25.38	19.00	25.38	25.38	6 x 2	25.38	38.00	25.00	22.50	42.25	42.25	8.81	25.00	

Dimensions in inches.

# SM (Mill Type) Design 2 Engineering Data

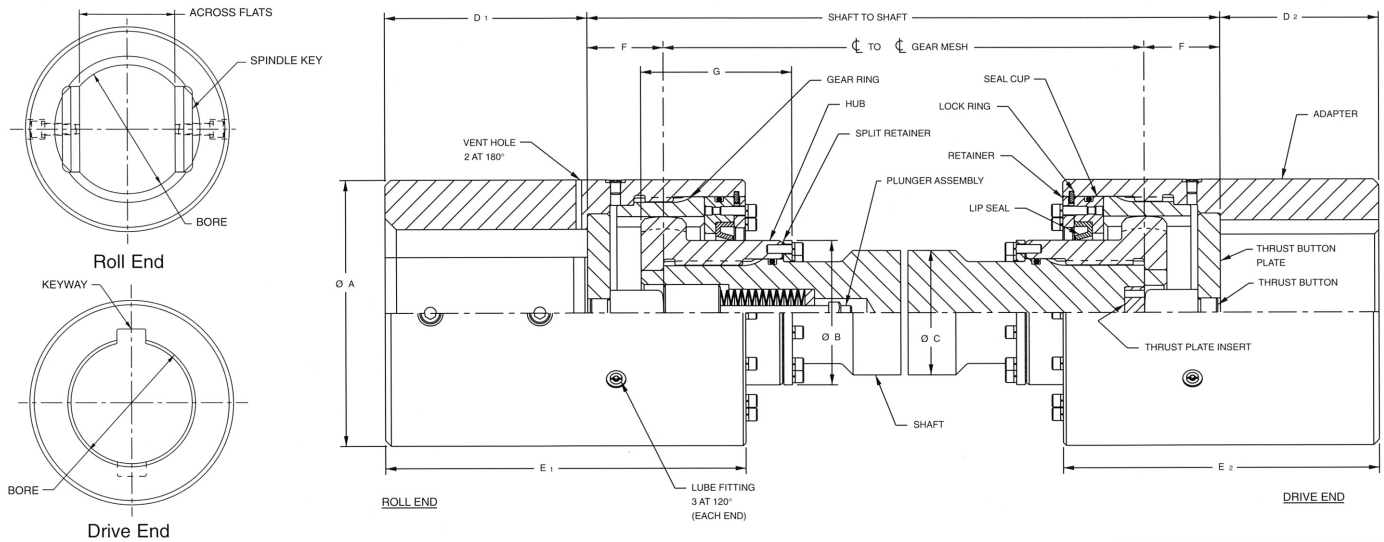

This optional spindle configuration shows the replaceable insert gear ring at both the roll and drive ends. The gear ring is connected to the adapter through a snug-fitting spline employing a flat root side fit. The gear ring is held concentric with the adapter by accurately machined

pilots in both ends of the spline engagement. If the gear ring is damaged for any reason, it can be replaced in a fraction of the time required to replace a sleeve which has an integral gear, and it has the added benefit of being much more economical.

Size O.D.	Roll End			Drive End			A	B	C	E1	E2	F	G
	Max. Bore	Max. Flats	D1	Max. Bore	Max. Keyway	D2							
8	5.38	4.00	5.38	5.38	1-1/4 x 5/8	5.38	8.00	4.12	3.75	10.13	10.13	2.19	4.12
10	6.63	5.00	6.63	6.63	1-3/4 x 3/4	6.63	10.00	5.62	5.00	12.25	12.25	2.56	5.62
12	8.00	6.00	8.00	8.00	2 x 3/4	8.00	12.00	6.38	5.75	16.88	16.88	3.94	6.38
14	9.38	7.00	9.38	9.38	2-1/2 x 7/8	9.38	14.00	7.75	7.00	17.88	17.88	4.00	7.75
16	10.63	8.00	10.63	10.63	2-1/2 x 7/8	10.63	16.00	9.00	8.13	21.25	21.25	4.75	9.00
18	12.00	9.00	12.00	12.00	3 x 1	12.00	18.00	11.00	9.88	23.13	23.13	5.00	11.00
20	13.38	10.00	13.38	13.38	3-1/2 x 1-1/4	13.38	20.00	12.00	10.75	23.63	23.63	4.94	12.00
22	14.63	11.00	14.63	14.63	3-1/2 x 1-1/4	14.63	22.00	13.50	12.13	26.63	26.63	5.69	13.50
24	16.00	12.00	16.00	16.00	4 x 1-1/2	16.00	24.00	15.75	14.13	27.50	27.50	5.81	15.75
27	18.00	13.50	18.00	18.00	4 x 1-1/2	18.00	27.00	17.25	15.50	31.50	31.50	6.44	17.25
29	19.38	14.50	19.38	19.38	5 x 1-3/4	19.38	29.00	18.50	16.63	32.88	32.88	6.44	18.50
31	20.63	15.50	20.63	20.63	5 x 1-3/4	20.63	31.00	21.00	18.88	36.50	36.50	8.19	21.00
33	22.00	16.50	22.00	22.00	5 x 1-3/4	22.00	33.00	21.00	18.88	38.75	38.75	8.63	21.00
35	23.38	17.50	23.38	23.38	6 x 2	23.38	35.00	24.50	22.00	40.13	40.13	8.63	24.50
37	24.63	18.50	24.63	24.63	6 x 2	24.63	37.00	25.00	22.50	42.13	42.13	8.63	25.00
39	26.00	19.50	26.00	26.00	6 x 2	26.00	39.00	25.00	22.50	43.50	43.50	8.63	25.00
41	27.38	20.50	27.38	27.38	7 x 2-1/2	27.38	41.00	25.00	22.50	44.88	44.88	8.63	25.00

Dimensions in inches.

# SM (Mill Type) Design 3 Engineering Data

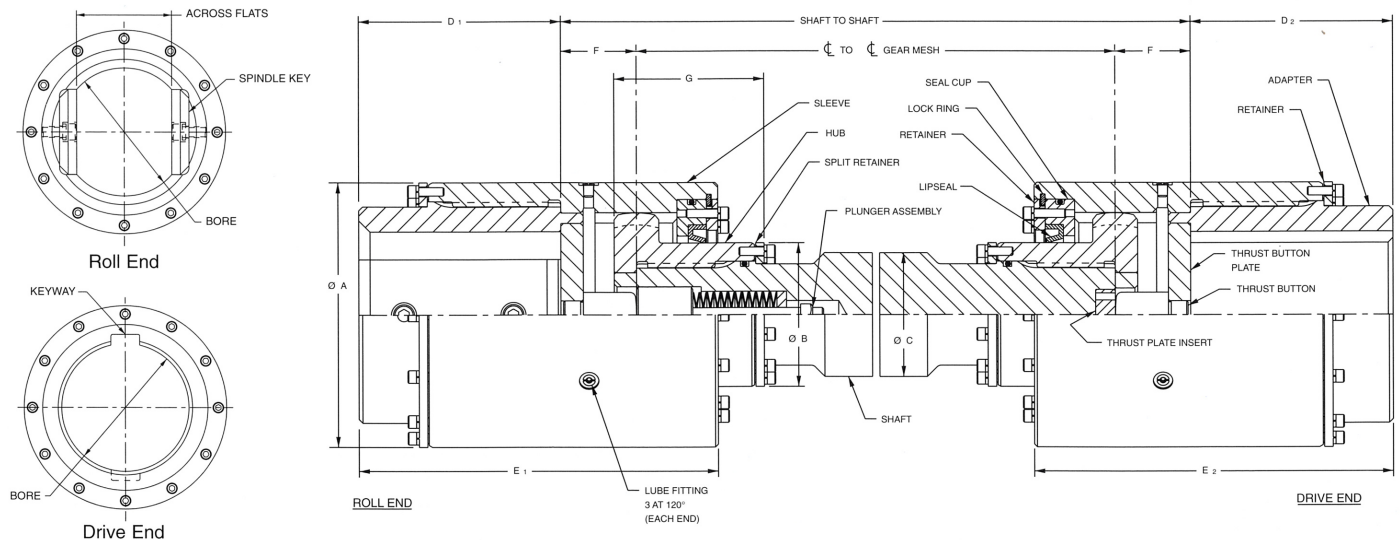

This spindle arrangement shows the splined replaceable sleeve option. This design has both an adapter which fits on the pinion shaft, and an intermediate sleeve that is splined to the adapter. This sleeve also has an internal gear which meshes with the hub.

This type of design is desirable in many cases where a quick disconnect feature is required. It also allows for an interchangeable sleeve that can be used on either end.

Size O.D.	Roll End			Drive End			A	B	C	E1	E2	F	G
	Max. Bore	Max. Flats	D1	Max. Bore	Max. Keyway	D2							
6	3.50	2.63	3.50	3.50	7/8 x 7/16	3.50	6.00	4.12	3.75	7.88	7.88	1.75	4.12
8	4.50	3.38	4.50	4.50	1 x 1/2	4.50	8.00	5.62	5.00	10.63	10.63	2.63	5.62
10	5.63	4.25	5.63	5.63	1-1/2 x 3/4	5.63	10.00	6.38	5.75	13.50	13.50	3.13	6.38
12	7.00	5.25	7.00	7.00	1-3/4 x 3/4	7.00	12.00	7.75	7.00	14.63	14.63	3.25	7.75
14	8.00	6.00	8.00	8.00	2 x 3/4	8.00	14.00	9.00	8.13	18.25	18.25	4.06	9.00
16	9.13	6.88	9.13	9.13	2-1/2 x 7/8	9.13	16.00	11.00	9.88	20.13	20.13	4.38	11.00
18	10.13	7.63	10.13	10.13	2-1/2 x 7/8	10.13	18.00	12.00	10.75	20.75	20.75	4.38	12.00
20	11.38	8.50	11.38	11.38	3 x 1	11.38	20.00	13.50	12.13	24.38	24.38	5.50	13.50
22	12.63	9.50	12.63	12.63	3 x 1	12.63	22.00	15.75	14.13	25.25	25.25	5.69	15.75
24	13.38	10.00	13.38	13.38	3-1/2 x 1-1/4	13.38	24.00	17.25	15.50	29.13	29.13	6.69	17.25
26	14.25	10.75	14.25	14.25	3-1/2 x 1-1/4	14.25	26.00	18.50	16.63	30.50	30.50	6.69	18.50
28	16.00	12.00	16.00	16.00	4 x 1/2	16.00	28.00	21.00	18.88	33.00	33.00	7.81	21.00
30	16.00	12.00	16.00	16.00	4 x 1/2	16.00	30.00	21.00	18.88	35.63	35.63	8.56	21.00
32	18.13	13.63	18.13	18.13	5 x 1-3/4	18.13	32.00	24.50	22.00	37.25	37.25	8.69	24.50
34	19.25	14.50	19.25	19.25	5 x 1-3/4	19.25	34.00	25.00	22.50	39.25	39.25	8.69	25.00
36	20.25	15.25	20.25	20.25	5 x 1-3/4	20.25	36.00	25.00	22.50	40.75	40.75	8.75	25.00
38	21.38	16.00	21.38	21.38	5 x 1-3/4	21.38	38.00	25.00	22.50	42.25	42.25	8.81	25.00

Dimensions in inches.



# SM (Mill Type) Design 4 Engineering Data

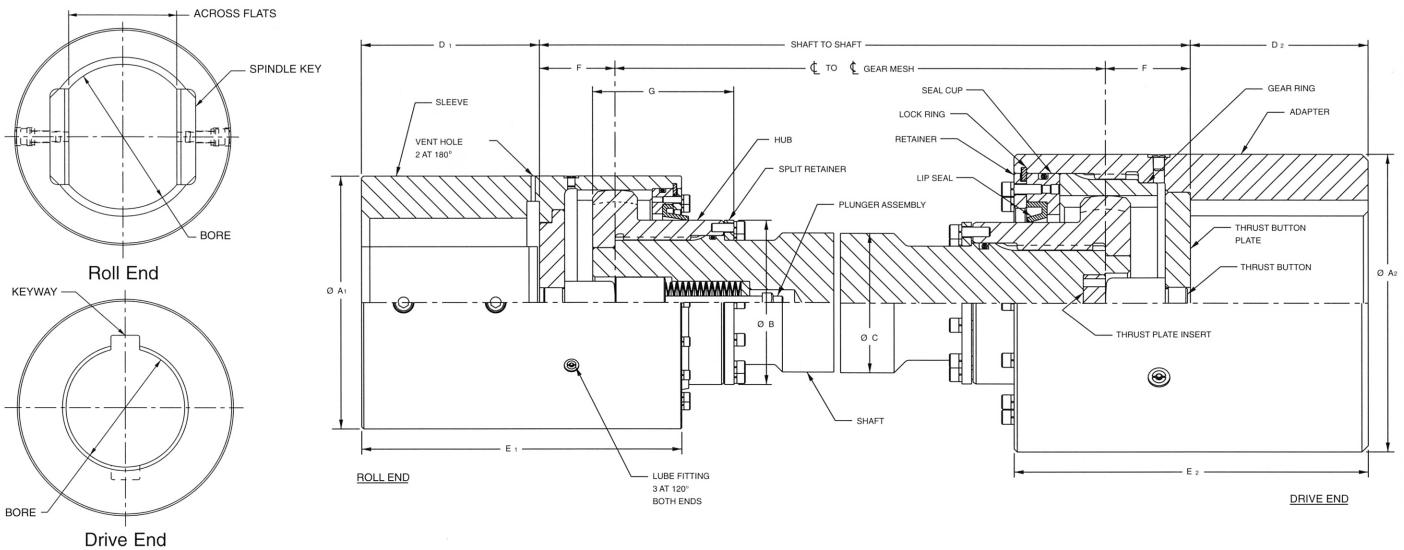

This arrangement is frequently used where diameter limitations prevent the use of a gear ring at the roll end. The spindle hubs can be interchangeable. This option allows the pinion end adapter to remain fixed to the pinion shaft when it becomes necessary to replace the gear ring.

Size	Roll End				Drive End				D2	B	C	E1	E2	F1	F2	G
	A1	Max. Bore	Max. Flats	D1	A2	Max. Bore	Max. Keyway									
6/8	6.00	4.00	3.00	4.00	8.00	5.38	1-1/4 x 5/8	5.38	4.12	3.75	7.88	10.13	1.75	2.19	4.12	
8/10	8.00	5.38	4.00	5.38	10.00	6.63	1-3/4 x 3/4	6.63	5.62	5.00	10.63	12.25	2.63	2.56	5.62	
10/12	10.00	6.63	5.00	6.63	12.00	8.00	2 x 3/4	8.00	6.38	5.75	13.50	16.88	3.13	3.94	6.38	
12/14	12.00	8.00	6.00	8.00	14.00	9.38	2-1/2 x 7/8	9.38	7.75	7.00	14.63	17.88	3.25	4.00	7.75	
14/16	14.00	9.38	7.00	9.38	16.00	10.63	2-1/2 x 7/8	10.63	9.00	8.13	18.25	21.25	4.06	4.75	9.00	
16/18	16.00	10.63	8.00	10.63	18.00	12.00	3 x 1	12.00	11.00	9.88	20.13	23.13	4.38	5.00	11.00	
18/20	18.00	12.00	9.00	12.00	20.00	13.38	3-1/2 x 1-1/4	13.38	12.00	10.75	20.75	23.63	4.38	4.94	12.00	
20/22	20.00	13.38	10.00	13.38	22.00	14.63	3-1/2 x 1-1/4	14.63	13.50	12.13	24.38	26.63	5.50	5.69	13.50	
22/24	22.00	14.63	11.00	14.63	24.00	16.00	4 x 1-1/2	16.00	15.75	14.13	25.25	27.50	5.69	5.81	15.75	
24/27	24.00	16.00	12.00	16.00	27.00	18.00	4 x 1-1/2	18.00	17.25	15.50	29.13	31.50	6.69	6.44	17.25	
26/29	26.00	17.38	13.00	17.38	29.00	19.38	5 x 1-3/4	19.38	18.50	16.63	30.50	32.88	6.69	6.44	18.50	
28/31	28.00	18.63	14.00	18.63	31.00	20.63	5 x 1-3/4	20.63	21.00	18.88	33.00	36.50	7.81	8.19	21.00	
30/33	30.00	20.00	15.00	20.00	33.00	22.00	5 x 1-3/4	22.00	21.00	18.88	35.63	38.75	8.56	8.63	21.00	
32/35	32.00	21.38	16.00	21.38	35.00	23.38	6 x 2	23.38	24.50	22.00	37.25	40.13	8.69	8.63	24.50	
34/37	34.00	22.63	17.00	22.63	37.00	24.63	6 x 2	24.63	25.00	22.50	39.25	42.13	8.69	8.63	25.00	
36/39	36.00	24.00	18.00	24.00	39.00	26.00	6 x 2	26.00	25.00	22.50	40.75	43.50	8.75	8.63	25.00	
38/41	38.00	25.38	19.00	25.38	41.00	27.38	7 x 2-1/2	27.38	25.00	22.50	42.25	44.88	8.81	8.63	25.00	

Dimensions in inches.

# Design Features

## Splined Hub (Figure 1)

Hubs are connected to the intermediate shaft through snug-fitting splines with a flat root side fit. The hub is held concentric with the spindle shaft by a close tolerance accurately machined pilot diameter on both ends of the spline. This holds the hub in a fixed position, able to resist radial load. The spline is used only to transmit torque. Relative movement between the internal and external spline is virtually non-existent, insuring that fretting and rapid wear cannot take place. Also, a spline requires less radial space than keys, permitting the use of larger shafts. Amerigear spindles are supplied with external hub retention. A split retainer is used which fits into a groove in the shaft and is through-bolted into the back of the hub. All internal bolting is eliminated which prevents the possibility of broken capscrews working into the gear teeth causing premature failure.

## Insert Gear Rings (Figure 2)

This component is connected to the adapter through snug-fitting flat root side fit spline. The gear ring is held concentric with the adapter by close toleranced pilots at both ends of the spline engagement. If the gear rings are damaged for any reason, they can be changed in a fraction of the time required to replace a larger one-piece sleeve. The gear ring replacement is also much more economical.

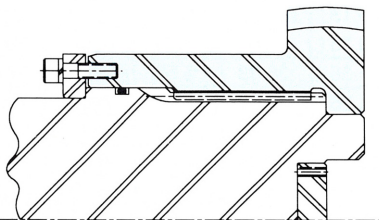

Figure 1 - Splined Hub

## Spring-Loaded Plunger Assembly (Figure 3)

Amerigear spindles can be designed to incorporate a spring loaded plunger assembly which holds the roll end coupling in line with the spindle shaft during roll change. When the roll neck is removed from the coupling, the spring force drives the sleeve assembly until it locks against the hub. The roll end sleeve is now in a horizontal position, ready to receive a new roll. All spindles are designed so the contact point of the thrust surface is located on the centerline of the gear mesh. This provides ball and socket action, rather than a sliding motion that occurs if the contact point is located on the thrust plate.

## Lock Ring Seal Assembly (Figure 4)

A split lock ring is used to retain the seal assembly to the sleeve or adapter. This allows for larger pitch diameter gearing since the lock ring requires less wall thickness than retainer bolts. Also, the lock ring design is much stronger than the bolted design and eliminates bolt breakage problems.

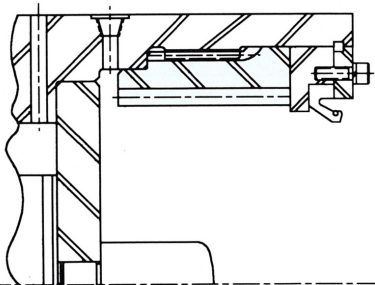

Figure 2 - Insert Gear Rings

## Lip Seals (Figure 5)

High angle lip type seals are provided on all Amerigear spindles. The Amerigear positive seal is an integral one-piece molded lip seal designed specifically for flexible spindle applications. The unique convoluted design combines positive sealing with maximum resilience and long life to keep vital lubricant in and damaging contaminants out. Special material can be supplied for severe atmospheric conditions.

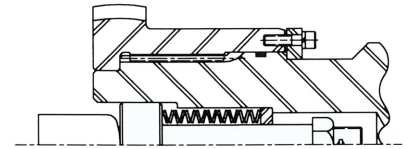

Figure 3 - Spring-Loaded Plunger Assembly

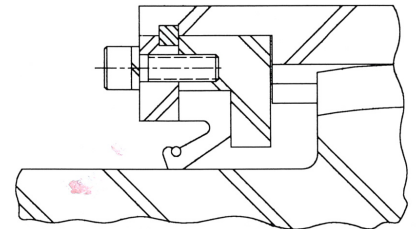

Figure 4 - Lock Ring Seal Assembly

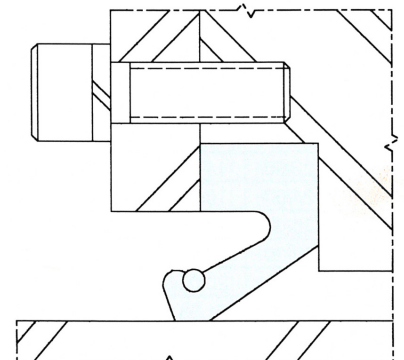
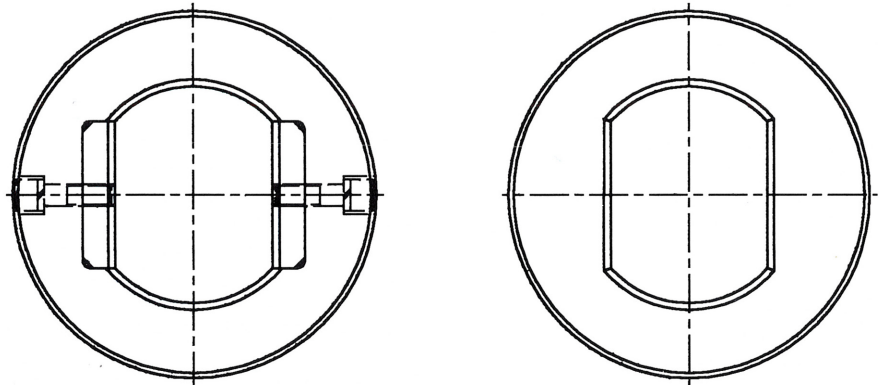

Figure 5 - Lip Seals

## Roll End Bores (Figure 6)

Amerigear spindles can be furnished with either a developed bore or replaceable wear keys. Keys can be hardened alloy steel or standard commercial steel depending on the application. A developed roll end bore configuration is available with or without heat treatment and hardening, based on the severity of the application. Roll end bores can be hardened by nitriding, carburizing or hard face welding.



REPLACEABLE SPINDLE KEY

DEVELOPED BORE

Figure 6

## Axial Travel Capability (Figure 7)

Various designs of SM spindles are available offering axial travel capability. These are most commonly used on mill stands that shift horizontally for various pass lines such as bar, rod and structural mills. Other uses include applications with vertical roll removal, roll shifting, special disconnecting requirements, special maintenance considerations and variable shaft separations. It is possible to accommodate axial travel requirements in excess of 60 inches. Figure 7 shows examples of axial travel design spindles.

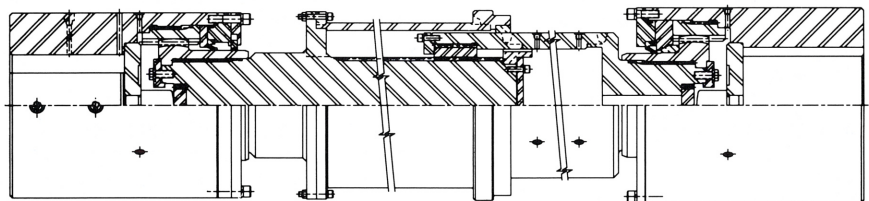

Variable length shaft assembly with 34 in. travel capability for vertical roll stand.

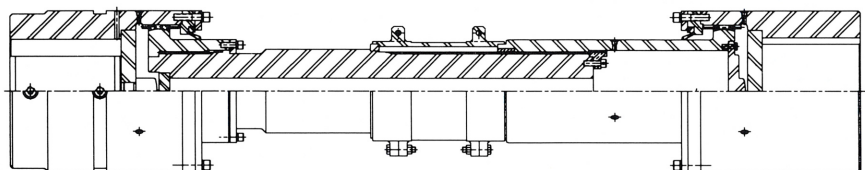

Fixed length design with removable split spacer that has 14 in. retraction for vertical roll removal.

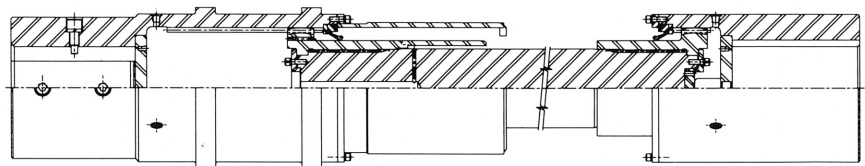

Collapsing design with 10.5 in. travel in the sleeve for roll change.

Figure 7

# Maintenance and Lubrication

## General Description

The Ameridrives Amerigear SM Type flexible spindles are designed primarily for heavy duty steel mill applications. These units fulfill the requirements of transmitting the maximum torque possible while operating at a specific angle of misalignment between driving and driven equipment. They also can be designed to allow for higher no load angle misalignments which makes roll change easier. The gear elements of the Amerigear spindle are made from high quality carbon or forged alloy steel depending on the operating angle and load requirements. Both the external and internal gear teeth are case hardened to provide longer wear life.

## Maintenance

Installation and Maintenance Manuals are provided for your specific Amerigear spindle. The manual contains fully detailed pre-installation preparations, disassembly procedures, and final installation/assembly instructions. There are also recommended schedules for cleaning, inspection and lubrication. It is extremely important that all gear spindles operate within the design parameters stated on the assembly drawing.

## Lubrication

One of the most important factors for successful operation and long spindle life is the use of the proper lubricant.

Since the fully-crowned gear teeth of a spindle are subjected to sliding and rolling action as the spindle rotates, the lubricant used should provide a low friction film between the working surfaces to reduce the possibility of wear and scoring. The lubricant should also have extreme pressure capability and good capacity for dissipating the heat generated from the sliding and rolling action of mating gear teeth.

## Type of Lubricant

The general requirements for fully-crowned gear type flexible spindle lubricants are:

1. High film strength
2. High heat resistant characteristics
3. Good retention characteristics
4. Extreme pressure capability

See ANSI/AGMA 9001-B97 "Flexible Couplings - Lubrication" for grease specifications. Contact Ameridrives Couplings for specific recommendations on lubricants which are suitable for your application.

Any lubricants listed on Ameridrives drawings or maintenance manuals are recommended by the lubricant manufacturers for the type of equipment on which the spindles are installed. The listings are solely for convenience purposes and do not constitute an endorsement. The listings are not intended to be complete nor necessarily current due to continuous research and improvement by manufacturers.

## Frequency and Manner of Lubrication

A rule for frequency of lubrication cannot be prescribed for all applications because of the variable conditions that must be considered, such as production schedules, ambient temperatures, operating angles, torque loads, mill position and atmosphere conditions. However, some general recommendations can be made. All spindles should be filled with a high quality lubricant. Prior to assembly, wipe each external and internal tooth with clean lubricant by hand. This prevents the spindle gear mesh from running dry until the lubricant works its way through all the teeth. When the spindle is assembled, fill it with the same lubricant.

One method of filling the spindle is to rotate the unit until one lube fitting is below the horizontal centerline of the spindle. Pump the recommended amount of lubricant into the gear mesh cavity. Follow this procedure at initial lubrication and whenever the spindles are completely washed out. Check the spindle frequently, particularly during the first month of operation, to assure adequate quantities of lubricant are maintained and to establish regular lubrication intervals which will depend on the operation of the equipment.

At least twice a year, disassemble the spindle, thoroughly wash it out, and inspect the parts for gear tooth wear as well as any other type of abnormal wear or damage.

Prior to re-assembly, coat the internal and external gear teeth with lubricant. Following assembly, fill the spindle with the proper lubricant as directed above.

## Expected Length of Service

The length of service which can be expected from Amerigear spindles is dependent upon several important factors. The first thing that must be considered is spindle design. Spindle design centers around a base set of operating conditions such as torque, angle and speed. Amerigear spindles are designed to operate at the most difficult combination of these factors. Variations in operating conditions are considered and safety factors are selected to allow for torque amplification due to impact loading or variations in material thickness. Cyclic loading is also considered and the appropriate service factor is applied to account for fatigue. The final design reflects a material selection, heat-treat processing, and a combination of safety factors based upon sound engineering practice and many years of experience with all types of mill drives.

In operation, several environmental and human factors contribute to spindle life. The maintenance of spindles is critical to successful operation. The quality, quantity and frequency of lubrication is a primary concern. Also, atmospheric conditions such as dust, moisture, heat and cold must be considered. In addition, system characteristics such as excessive backlash, worn bearings, torque variations, as well as material being rolled, must be taken into account.

Problems in any of these areas can adversely affect spindle life. The best measure of service will be found by studying the life cycle of components on each individual mill.

## Caution:

Rotating equipment is potentially dangerous and could cause injury or damage if not properly protected. Follow applicable codes and regulations.

# SL and SF General Guide for Size and Material Selection

## Spindle Selection

Step 1 - Calculate service torque (Ts) including appropriate service factor.

$$T_s = \frac{H.P. \times 63,025}{RPM} \times S.F.$$

Step 2 - Select spindle size (O.D.) and type from table below.

Step 3 - Check adapter bore capacity with equipment shafts (see pages 14-15)

Step 4 - Find torque capacity of chosen size from charts below. Be sure to look in the proper column which corresponds to the full load operating angle of the spindle. Compare torque capacity to the calculated service torque (Ts). Torque capacity must be greater than Ts. If Ts is greater than the torque capacity, select larger spindle or alternative material.

Load	Driven Equipment	Service Factors	
		Continuous, Non-Reversing Motors & Turbines	Reversing D.C. Motors & Reciprocating Engines
Medium Shock	Pumps, Lumber Machinery, Paper Mill Equipment, Bar & Rod Mills, Cold Mills & Auxiliary Equipment	1.25	1.5
Heavy Shock	Presses, Mixers, Crane Drives, Mining Equipment, Hot Roll Mills, Runout Tables & Feed Roll Mills	1.75	2.75

AISI-1045 Induction Hardened								
Spindle Size in.		Torque Capacity (In.lb. x 10 <sup>3</sup> ) For Misalignments Indicated						
SL	SF	1°	1.5°	2°	3°	4°	5°	6°
2.62	3.56	4.5	3.8	3.2	2.3	1.8	1.4	0.9
3.00	4.00	7.9	6.6	5.5	4.0	3.2	2.4	1.6
4.00	6.00	19.1	16.0	13.4	9.6	7.6	5.7	3.8
5.00	7.00	38.4	32.3	26.9	19.2	15.4	11.5	7.7
6.00	8.38	64.8	54.4	45.4	32.4	25.9	19.4	13.0
7.00	9.44	113.1	95.0	79.2	56.6	45.2	33.9	22.6
8.00	11.00	176.8	148.5	123.8	88.4	70.7	53.0	35.4
9.00	12.50	264.6	222.3	185.2	132.3	105.8	79.4	52.9
10.00	13.62	380.6	319.7	266.4	190.3	152.2	114.2	76.1
11.62	15.31	639.6	537.3	447.7	319.8	255.8	191.9	127.9
12.62	16.56	855.6	718.7	598.9	427.8	342.2	256.7	171.1
14.00	18.00	1,218.5	1,023.5	853.0	609.3	487.4	365.6	243.7
15.75	20.75	1,679.2	1,410.5	1,175.4	839.6	671.7	503.8	335.8

Dimensions in inches.

AISI-4140 Induction Hardened								
Spindle Size in.		Torque Capacity (In.lb. x 10 <sup>3</sup> ) For Misalignments Indicated						
SL	SF	1°	1.5°	2°	3°	4°	5°	6°
2.62	3.56	6.8	5.7	4.7	3.4	2.7	2.0	1.4
3.00	4.00	11.9	10.0	8.3	5.9	4.7	3.6	2.4
4.00	6.00	28.7	24.1	20.1	14.3	11.5	8.6	5.7
5.00	7.00	57.6	48.4	40.3	28.8	23.0	17.3	11.5
6.00	8.38	97.2	81.6	68.0	48.6	38.9	29.2	19.4
7.00	9.44	169.7	142.5	118.8	84.8	67.9	50.9	33.9
8.00	11.00	265.2	222.8	185.6	132.6	106.1	79.6	53.0
9.00	12.50	396.9	333.4	277.8	198.5	158.8	119.1	79.4
10.00	13.62	570.9	479.6	399.6	285.5	228.4	171.3	114.2
11.62	15.31	1,212.0	1,018.1	848.4	606.0	484.8	363.6	242.4
12.62	16.56	1,621.4	1,361.9	1,135.0	810.7	648.5	486.4	324.3
14.00	18.00	2,291.9	1,925.2	1,604.3	1,146.0	916.8	687.6	458.4
15.75	20.75	3,128.8	2,628.2	2,190.2	1,564.4	1,251.5	938.6	625.8

Dimensions in inches.

**Note: Table reflects full load angle torque capability.**

Above couplings have ± 6° angular misalignment capacity per gear mesh.

SL and SF spindles are furnished with medium carbon steel shafts. In some cases where torque levels are high, heat treated alloy steel shafts may be required.

Consult the factory for verification of your selection.

# SL (Leveler Type) | Engineering Data

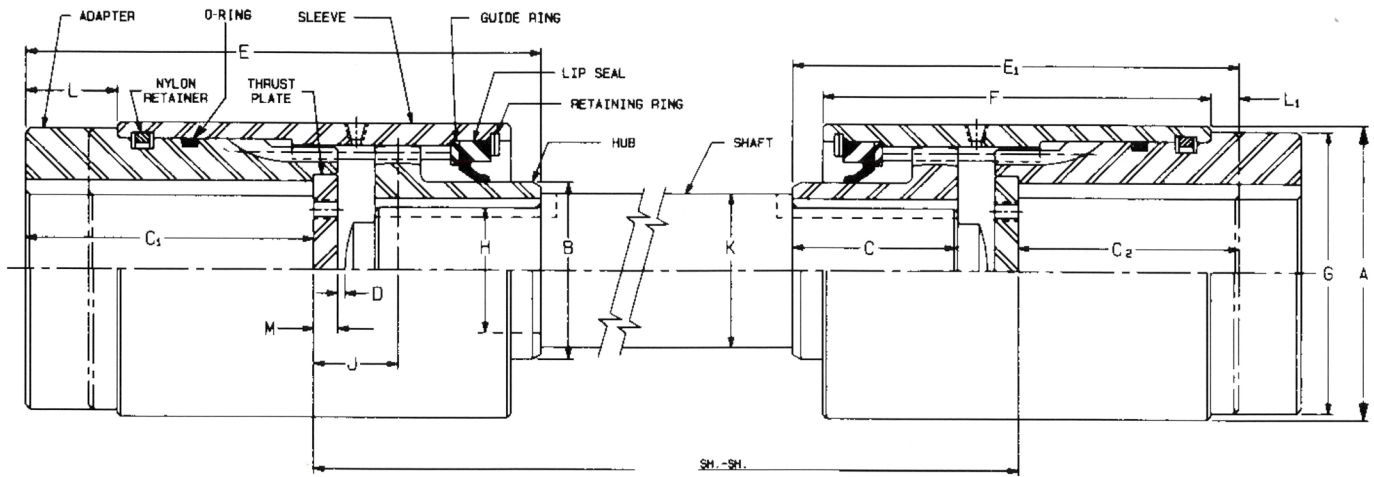

## Application

The SL Spindle is for medium torque applications where high misalignment capacity is required and where equipment must be disconnected quickly and/or frequently. Typical applications include drives for auxiliary equipment such as levelers, uncoilers, side trimmers, tension

and payoff reels, run-out tables, pinch rolls, brush rolls, bridles, flatteners, and scale breakers.

SL Spindles can also be used on applications where shaft center-to-center spacing is minimal and where diameters are limited.

## Description

The Amerigear Series SL Flexible Spindle is designed to deliver maximum torque in a limited space at relatively high misalignments. The quick disconnect sleeve design permits rapid and easy installation or removal of the spindle without removing the drive or driven equipment. The gear sleeves are positively secured to the adapter with a unique retaining ring design.

See page 13 for Torque Capacities.

Size	Adapter Bore and Keyway Data				Dimensions														Dimensions With Minimum Length Adapter		
	Square Key		Reduced Key		A	B	C	C <sub>1</sub>	D	E	F	G	H	J	K	L	M	C <sub>2</sub>	E <sub>1</sub>	L <sub>1</sub>	
	Max. Bore	Keyway	Max. Bore	Keyway																	
2 <sup>5</sup> / <sub>8</sub>	1 <sup>1</sup> / <sub>16</sub>	3/8 x 3/16	1 <sup>1</sup> / <sub>16</sub>	3/8 x 1/8	2 <sup>5</sup> / <sub>8</sub>	1 <sup>1</sup> / <sub>8</sub>	1 <sup>1</sup> / <sub>8</sub>	1 <sup>15</sup> / <sub>16</sub>	1/16	3 <sup>27</sup> / <sub>32</sub>	3 <sup>3</sup> / <sub>16</sub>	2 <sup>7</sup> / <sub>16</sub>	1	1 <sup>1</sup> / <sub>16</sub>	1 <sup>1</sup> / <sub>8</sub>	3/32	1/4	1 <sup>19</sup> / <sub>16</sub>	3 <sup>27</sup> / <sub>32</sub>	3/32	
2 <sup>3</sup> / <sub>4</sub>	1 <sup>1</sup> / <sub>16</sub>	3/8 x 3/16	1 <sup>11</sup> / <sub>16</sub>	3/8 x 1/8	2 <sup>3</sup> / <sub>4</sub>	1 <sup>11</sup> / <sub>16</sub>	1 <sup>1</sup> / <sub>2</sub>	1 <sup>31</sup> / <sub>32</sub>	1/16	3 <sup>31</sup> / <sub>32</sub>	3 <sup>3</sup> / <sub>8</sub>	2 <sup>11</sup> / <sub>16</sub>	1 <sup>1</sup> / <sub>8</sub>	1 <sup>1</sup> / <sub>16</sub>	1 <sup>1</sup> / <sub>4</sub>	3/16	1/4	1 <sup>31</sup> / <sub>32</sub>	3 <sup>31</sup> / <sub>32</sub>	3/16	
2 <sup>7</sup> / <sub>8</sub>	1 <sup>11</sup> / <sub>16</sub>	3/8 x 3/16	1 <sup>3</sup> / <sub>4</sub>	3/8 x 1/8	2 <sup>7</sup> / <sub>8</sub>	1 <sup>13</sup> / <sub>16</sub>	1 <sup>5</sup> / <sub>8</sub>	2	1/16	4 <sup>3</sup> / <sub>16</sub>	3 <sup>3</sup> / <sub>8</sub>	2 <sup>19</sup> / <sub>16</sub>	1 <sup>1</sup> / <sub>8</sub>	3/4	1 <sup>1</sup> / <sub>2</sub>	3/16	1/4	2	4 <sup>3</sup> / <sub>16</sub>	3/16	
3	1 <sup>1</sup> / <sub>4</sub>	3/8 x 3/16	1 <sup>13</sup> / <sub>16</sub>	1/2 x 3/16	3	1 <sup>1</sup> / <sub>8</sub>	1 <sup>11</sup> / <sub>16</sub>	2 <sup>1</sup> / <sub>4</sub>	1/16	4 <sup>1</sup> / <sub>2</sub>	3 <sup>15</sup> / <sub>16</sub>	2 <sup>15</sup> / <sub>16</sub>	1 <sup>1</sup> / <sub>4</sub>	3/4	1 <sup>5</sup> / <sub>8</sub>	3/16	1/4	2 <sup>1</sup> / <sub>4</sub>	4 <sup>1</sup> / <sub>2</sub>	3/16	
3 <sup>3</sup> / <sub>8</sub>	1 <sup>15</sup> / <sub>16</sub>	1/2 x 1/4	2	1/2 x 3/16	3 <sup>3</sup> / <sub>8</sub>	2 <sup>1</sup> / <sub>4</sub>	1 <sup>3</sup> / <sub>4</sub>	2 <sup>1</sup> / <sub>4</sub>	1/16	4 <sup>17</sup> / <sub>32</sub>	4	3 <sup>5</sup> / <sub>16</sub>	1 <sup>3</sup> / <sub>8</sub>	3/4	1 <sup>3</sup> / <sub>4</sub>	1/4	1/4	2 <sup>3</sup> / <sub>16</sub>	4 <sup>15</sup> / <sub>32</sub>	3/16	
3 <sup>1</sup> / <sub>2</sub>	2	1/2 x 1/4	2 <sup>1</sup> / <sub>8</sub>	1/2 x 3/16	3 <sup>1</sup> / <sub>2</sub>	2 <sup>5</sup> / <sub>8</sub>	1 <sup>13</sup> / <sub>16</sub>	2 <sup>1</sup> / <sub>2</sub>	1/16	4 <sup>31</sup> / <sub>32</sub>	4 <sup>1</sup> / <sub>8</sub>	3 <sup>7</sup> / <sub>16</sub>	1 <sup>1</sup> / <sub>2</sub>	7/8	1 <sup>1</sup> / <sub>4</sub>	1/2	1/4	2 <sup>3</sup> / <sub>16</sub>	4 <sup>21</sup> / <sub>32</sub>	3/16	
3 <sup>3</sup> / <sub>4</sub>	2 <sup>1</sup> / <sub>8</sub>	1/2 x 1/4	2 <sup>1</sup> / <sub>4</sub>	1/2 x 3/16	3 <sup>3</sup> / <sub>4</sub>	2 <sup>1</sup> / <sub>2</sub>	1 <sup>5</sup> / <sub>8</sub>	2 <sup>1</sup> / <sub>8</sub>	1/16	5 <sup>5</sup> / <sub>8</sub>	4 <sup>3</sup> / <sub>8</sub>	3 <sup>1</sup> / <sub>16</sub>	1 <sup>1</sup> / <sub>8</sub>	7/8	1 <sup>1</sup> / <sub>8</sub>	3/4	1/4	2 <sup>3</sup> / <sub>16</sub>	4 <sup>13</sup> / <sub>16</sub>	3/16	
4	2 <sup>1</sup> / <sub>4</sub>	1/2 x 1/4	2 <sup>3</sup> / <sub>8</sub>	5/8 x 7/32	4	2 <sup>5</sup> / <sub>8</sub>	1 <sup>15</sup> / <sub>16</sub>	3	1/8	5 <sup>11</sup> / <sub>16</sub>	4 <sup>1</sup> / <sub>2</sub>	3 <sup>3</sup> / <sub>8</sub>	1 <sup>1</sup> / <sub>4</sub>	1	1 <sup>1</sup> / <sub>8</sub>	1 <sup>13</sup> / <sub>16</sub>	1/4	2 <sup>3</sup> / <sub>8</sub>	5 <sup>1</sup> / <sub>16</sub>	3/16	
5	3	3/4 x 3/8	3 <sup>3</sup> / <sub>8</sub>	3/4 x 1/4	5	3 <sup>3</sup> / <sub>8</sub>	2 <sup>1</sup> / <sub>16</sub>	3 <sup>3</sup> / <sub>8</sub>	1/8	7 <sup>1</sup> / <sub>8</sub>	5 <sup>1</sup> / <sub>2</sub>	4 <sup>1</sup> / <sub>8</sub>	2 <sup>1</sup> / <sub>8</sub>	1 <sup>1</sup> / <sub>8</sub>	2 <sup>1</sup> / <sub>4</sub>	1	1/4	3 <sup>3</sup> / <sub>16</sub>	6 <sup>1</sup> / <sub>16</sub>	5/16	
6	3 <sup>3</sup> / <sub>16</sub>	7/8 x 1/16	3 <sup>5</sup> / <sub>8</sub>	7/8 x 5/16	6	4 <sup>1</sup> / <sub>8</sub>	3 <sup>19</sup> / <sub>32</sub>	4 <sup>1</sup> / <sub>2</sub>	1/8	8 <sup>21</sup> / <sub>32</sub>	6 <sup>3</sup> / <sub>8</sub>	5 <sup>1</sup> / <sub>8</sub>	2 <sup>1</sup> / <sub>8</sub>	1 <sup>1</sup> / <sub>2</sub>	3	1 <sup>1</sup> / <sub>4</sub>	3/8	3 <sup>3</sup> / <sub>8</sub>	7 <sup>25</sup> / <sub>32</sub>	3/8	
7	4 <sup>1</sup> / <sub>16</sub>	1 x 1/2	4 <sup>1</sup> / <sub>4</sub>	1 x 3/8	7	5 <sup>5</sup> / <sub>8</sub>	3 <sup>19</sup> / <sub>32</sub>	5 <sup>1</sup> / <sub>4</sub>	1/8	9 <sup>29</sup> / <sub>32</sub>	6 <sup>3</sup> / <sub>4</sub>	6 <sup>3</sup> / <sub>8</sub>	3 <sup>1</sup> / <sub>2</sub>	1 <sup>1</sup> / <sub>2</sub>	3 <sup>1</sup> / <sub>2</sub>	1 <sup>1</sup> / <sub>8</sub>	3/8	3 <sup>3</sup> / <sub>16</sub>	8 <sup>15</sup> / <sub>32</sub>	7/16	
8	4 <sup>1</sup> / <sub>8</sub>	1 <sup>1</sup> / <sub>4</sub> x 3/8	5 <sup>3</sup> / <sub>16</sub>	1 <sup>1</sup> / <sub>4</sub> x 7/16	8	5 <sup>5</sup> / <sub>8</sub>	4 <sup>1</sup> / <sub>16</sub>	6 <sup>1</sup> / <sub>2</sub>	1/8	11 <sup>15</sup> / <sub>16</sub>	7 <sup>1</sup> / <sub>16</sub>	7 <sup>7</sup> / <sub>8</sub>	3 <sup>3</sup> / <sub>8</sub>	1 <sup>1</sup> / <sub>4</sub>	4	2 <sup>1</sup> / <sub>16</sub>	3/8	4 <sup>1</sup> / <sub>2</sub>	9 <sup>15</sup> / <sub>16</sub>	3/16	
9	5 <sup>1</sup> / <sub>2</sub>	1 <sup>1</sup> / <sub>4</sub> x 3/8	5 <sup>3</sup> / <sub>4</sub>	1 <sup>1</sup> / <sub>2</sub> x 1/2	9	6 <sup>1</sup> / <sub>2</sub>	4 <sup>3</sup> / <sub>4</sub>	7 <sup>1</sup> / <sub>8</sub>	1/8	13 <sup>3</sup> / <sub>16</sub>	8 <sup>3</sup> / <sub>8</sub>	8 <sup>3</sup> / <sub>8</sub>	4 <sup>1</sup> / <sub>16</sub>	1 <sup>1</sup> / <sub>8</sub>	4 <sup>5</sup> / <sub>8</sub>	3	1/2	4 <sup>3</sup> / <sub>4</sub>	10 <sup>13</sup> / <sub>16</sub>	5/8	
10	6 <sup>1</sup> / <sub>4</sub>	1 <sup>1</sup> / <sub>2</sub> x 3/4	6 <sup>1</sup> / <sub>2</sub>	1 <sup>1</sup> / <sub>2</sub> x 1/2	10	7 <sup>1</sup> / <sub>4</sub>	5 <sup>5</sup> / <sub>16</sub>	8 <sup>1</sup> / <sub>8</sub>	1/8	14 <sup>7</sup> / <sub>8</sub>	9 <sup>1</sup> / <sub>4</sub>	9 <sup>9</sup> / <sub>16</sub>	4 <sup>1</sup> / <sub>16</sub>	2 <sup>1</sup> / <sub>16</sub>	5 <sup>5</sup> / <sub>8</sub>	3 <sup>3</sup> / <sub>16</sub>	1/2	5 <sup>5</sup> / <sub>16</sub>	12 <sup>1</sup> / <sub>16</sub>	5/8	
11 <sup>5</sup> / <sub>8</sub>	7	1 <sup>1</sup> / <sub>4</sub> x 7/8	7 <sup>1</sup> / <sub>2</sub>	1 <sup>1</sup> / <sub>4</sub> x 3/8	11 <sup>5</sup> / <sub>8</sub>	8 <sup>1</sup> / <sub>2</sub>	6 <sup>3</sup> / <sub>32</sub>	9 <sup>3</sup> / <sub>8</sub>	3/16	16 <sup>31</sup> / <sub>32</sub>	10 <sup>1</sup> / <sub>4</sub>	11 <sup>3</sup> / <sub>8</sub>	5 <sup>1</sup> / <sub>16</sub>	2 <sup>1</sup> / <sub>4</sub>	5 <sup>3</sup> / <sub>4</sub>	4 <sup>1</sup> / <sub>16</sub>	1/2	5 <sup>3</sup> / <sub>4</sub>	13 <sup>11</sup> / <sub>32</sub>	7/16	
12 <sup>5</sup> / <sub>8</sub>	7 <sup>3</sup> / <sub>4</sub>	2 x 1	8 <sup>3</sup> / <sub>4</sub>	2 x 3/4	12 <sup>5</sup> / <sub>8</sub>	9	6 <sup>3</sup> / <sub>8</sub>	10 <sup>1</sup> / <sub>4</sub>	3/16	18 <sup>11</sup> / <sub>16</sub>	11	12 <sup>3</sup> / <sub>8</sub>	5 <sup>1</sup> / <sub>16</sub>	2 <sup>3</sup> / <sub>16</sub>	6 <sup>1</sup> / <sub>4</sub>	4 <sup>1</sup> / <sub>16</sub>	1/2	6 <sup>1</sup> / <sub>16</sub>	14 <sup>1</sup> / <sub>2</sub>	3/8	
14	8 <sup>1</sup> / <sub>2</sub>	2 x 1	8 <sup>15</sup> / <sub>16</sub>	2 x 3/4	14	10	7 <sup>13</sup> / <sub>32</sub>	11 <sup>1</sup> / <sub>4</sub>	1/16	20 <sup>17</sup> / <sub>32</sub>	12 <sup>1</sup> / <sub>4</sub>	13 <sup>3</sup> / <sub>4</sub>	6 <sup>1</sup> / <sub>16</sub>	2 <sup>1</sup> / <sub>16</sub>	7	4 <sup>1</sup> / <sub>8</sub>	1/2	7 <sup>1</sup> / <sub>8</sub>	16 <sup>13</sup> / <sub>32</sub>	3/4	
15 <sup>3</sup> / <sub>4</sub>	10	2 <sup>1</sup> / <sub>2</sub> x 1 <sup>1</sup> / <sub>4</sub>	10 <sup>3</sup> / <sub>4</sub>	2 <sup>1</sup> / <sub>2</sub> x 7/8	15 <sup>3</sup> / <sub>4</sub>	12	8 <sup>1</sup> / <sub>16</sub>	13 <sup>1</sup> / <sub>2</sub>	3/16	24 <sup>1</sup> / <sub>4</sub>	13 <sup>1</sup> / <sub>2</sub>	15 <sup>1</sup> / <sub>2</sub>	6 <sup>1</sup> / <sub>16</sub>	2 <sup>9</sup> / <sub>16</sub>	7 <sup>1</sup> / <sub>2</sub>	6 <sup>1</sup> / <sub>16</sub>	1/2	8 <sup>1</sup> / <sub>2</sub>	19 <sup>1</sup> / <sub>4</sub>	1 <sup>1</sup> / <sub>16</sub>	

Note: Adapter engagement length is variable from Std. C<sub>1</sub> to minimum length C<sub>2</sub>.

Dimensions in inches.

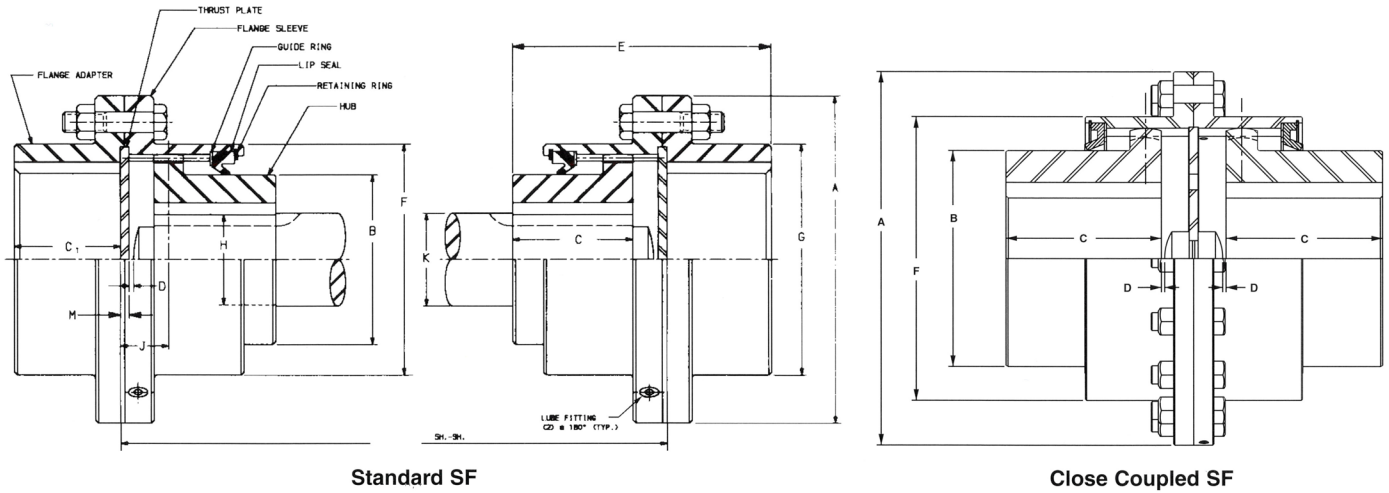

Standard SF

Close Coupled SF

### Application

The SL Spindle is for medium torque applications where high misalignment capacity is required. It is used on applications where equipment is not subjected to frequent disconnecting of drive components. Typical applications include auxiliary equipment such as pinch rolls, tension bridles, continuous casting

equipment, plastic and rubber calenders, rotary side guides, paper mills, as well as electrolytic cleaning, pickle and galvanizing lines.

### Description

The Amerigear Series SF Flexible Spindle is similar to a tandem arrangement using flange-type couplings (Series F) except

the gearing will accommodate higher misalignment. The gear teeth are heat treated to provide higher torque ratings and special molded high angle lip type seals are used. Close coupled SF spindles are also available.

See page 13 for Torque Capacities.

Size	Adapter Bore and Keyway Data				Dimensions												
	Square Key		Reduced Key		A	B	C	C <sub>1</sub>	D	E	F	G	H	J	K	M	
	Max. Bore	Keyway	Max. Bore	Keyway													
3 <sup>3</sup> / <sub>16</sub>	1 <sup>3</sup> / <sub>4</sub>	<sup>3</sup> / <sub>8</sub> x <sup>3</sup> / <sub>16</sub>	1 <sup>1</sup> / <sub>8</sub>	<sup>3</sup> / <sub>8</sub> x <sup>1</sup> / <sub>8</sub>	3 <sup>3</sup> / <sub>16</sub>	1 <sup>5</sup> / <sub>8</sub>	1 <sup>3</sup> / <sub>8</sub>	1 <sup>3</sup> / <sub>8</sub>	<sup>1</sup> / <sub>16</sub>	3 <sup>3</sup> / <sub>32</sub>	2 <sup>5</sup> / <sub>8</sub>	2 <sup>9</sup> / <sub>16</sub>	1	1 <sup>1</sup> / <sub>16</sub>	1 <sup>1</sup> / <sub>8</sub>	<sup>1</sup> / <sub>4</sub>	
4	2	<sup>1</sup> / <sub>2</sub> x <sup>1</sup> / <sub>4</sub>	2 <sup>1</sup> / <sub>8</sub>	<sup>1</sup> / <sub>2</sub> x <sup>3</sup> / <sub>16</sub>	4	1 <sup>1</sup> / <sub>8</sub>	1 <sup>11</sup> / <sub>16</sub>	1 <sup>11</sup> / <sub>16</sub>	<sup>1</sup> / <sub>16</sub>	3 <sup>19</sup> / <sub>16</sub>	3	3	1 <sup>1</sup> / <sub>4</sub>	<sup>3</sup> / <sub>4</sub>	1 <sup>1</sup> / <sub>8</sub>	<sup>1</sup> / <sub>4</sub>	
6	2 <sup>1</sup> / <sub>16</sub>	<sup>5</sup> / <sub>8</sub> x <sup>5</sup> / <sub>16</sub>	2 <sup>7</sup> / <sub>8</sub>	<sup>5</sup> / <sub>8</sub> x <sup>7</sup> / <sub>32</sub>	6	2 <sup>5</sup> / <sub>8</sub>	1 <sup>15</sup> / <sub>16</sub>	1 <sup>3</sup> / <sub>4</sub>	<sup>1</sup> / <sub>8</sub>	4 <sup>1</sup> / <sub>16</sub>	3 <sup>3</sup> / <sub>8</sub>	3 <sup>3</sup> / <sub>8</sub>	1 <sup>3</sup> / <sub>4</sub>	1	1 <sup>1</sup> / <sub>8</sub>	<sup>1</sup> / <sub>4</sub>	
7	3 <sup>1</sup> / <sub>4</sub>	<sup>7</sup> / <sub>8</sub> x <sup>7</sup> / <sub>16</sub>	3 <sup>1</sup> / <sub>2</sub>	<sup>7</sup> / <sub>8</sub> x <sup>3</sup> / <sub>16</sub>	7	3 <sup>3</sup> / <sub>8</sub>	2 <sup>7</sup> / <sub>16</sub>	2 <sup>1</sup> / <sub>4</sub>	<sup>1</sup> / <sub>8</sub>	5 <sup>1</sup> / <sub>2</sub>	5	4 <sup>7</sup> / <sub>8</sub>	2 <sup>1</sup> / <sub>8</sub>	1 <sup>1</sup> / <sub>8</sub>	2 <sup>1</sup> / <sub>4</sub>	<sup>1</sup> / <sub>4</sub>	
8 <sup>3</sup> / <sub>8</sub>	4	1 x <sup>1</sup> / <sub>2</sub>	4 <sup>1</sup> / <sub>4</sub>	1 x <sup>3</sup> / <sub>8</sub>	8 <sup>3</sup> / <sub>8</sub>	4 <sup>1</sup> / <sub>8</sub>	3 <sup>1</sup> / <sub>32</sub>	2 <sup>13</sup> / <sub>16</sub>	<sup>1</sup> / <sub>8</sub>	6 <sup>31</sup> / <sub>32</sub>	6	5 <sup>7</sup> / <sub>8</sub>	2 <sup>1</sup> / <sub>8</sub>	1 <sup>1</sup> / <sub>2</sub>	3	<sup>3</sup> / <sub>8</sub>	
9 <sup>7</sup> / <sub>16</sub>	4 <sup>5</sup> / <sub>8</sub>	1 <sup>1</sup> / <sub>4</sub> x <sup>5</sup> / <sub>8</sub>	5	1 <sup>1</sup> / <sub>4</sub> x <sup>7</sup> / <sub>16</sub>	9 <sup>7</sup> / <sub>16</sub>	5 <sup>1</sup> / <sub>8</sub>	3 <sup>19</sup> / <sub>32</sub>	3 <sup>5</sup> / <sub>16</sub>	<sup>1</sup> / <sub>8</sub>	7 <sup>31</sup> / <sub>32</sub>	7	6 <sup>13</sup> / <sub>16</sub>	3 <sup>3</sup> / <sub>8</sub>	1 <sup>1</sup> / <sub>2</sub>	3 <sup>1</sup> / <sub>2</sub>	<sup>3</sup> / <sub>8</sub>	
11	5 <sup>3</sup> / <sub>8</sub>	1 <sup>1</sup> / <sub>4</sub> x <sup>3</sup> / <sub>8</sub>	5 <sup>3</sup> / <sub>4</sub>	1 <sup>1</sup> / <sub>4</sub> x <sup>7</sup> / <sub>16</sub>	11	5 <sup>5</sup> / <sub>8</sub>	4 <sup>3</sup> / <sub>16</sub>	3 <sup>3</sup> / <sub>8</sub>	<sup>1</sup> / <sub>8</sub>	9 <sup>5</sup> / <sub>16</sub>	8	7 <sup>3</sup> / <sub>4</sub>	3 <sup>3</sup> / <sub>8</sub>	1 <sup>3</sup> / <sub>4</sub>	4	<sup>3</sup> / <sub>8</sub>	
12 <sup>1</sup> / <sub>2</sub>	6 <sup>1</sup> / <sub>4</sub>	1 <sup>1</sup> / <sub>2</sub> x <sup>3</sup> / <sub>4</sub>	6 <sup>3</sup> / <sub>4</sub>	1 <sup>1</sup> / <sub>2</sub> x <sup>1</sup> / <sub>2</sub>	12 <sup>1</sup> / <sub>2</sub>	6 <sup>1</sup> / <sub>2</sub>	4 <sup>1</sup> / <sub>4</sub>	4 <sup>3</sup> / <sub>8</sub>	<sup>1</sup> / <sub>8</sub>	10 <sup>7</sup> / <sub>16</sub>	9 <sup>9</sup> / <sub>16</sub>	9 <sup>9</sup> / <sub>16</sub>	4 <sup>7</sup> / <sub>16</sub>	1 <sup>1</sup> / <sub>8</sub>	4 <sup>5</sup> / <sub>8</sub>	<sup>1</sup> / <sub>2</sub>	
13 <sup>3</sup> / <sub>8</sub>	6 <sup>3</sup> / <sub>4</sub>	1 <sup>3</sup> / <sub>4</sub> x <sup>7</sup> / <sub>8</sub>	7 <sup>3</sup> / <sub>8</sub>	1 <sup>3</sup> / <sub>4</sub> x <sup>3</sup> / <sub>8</sub>	13 <sup>3</sup> / <sub>8</sub>	7 <sup>1</sup> / <sub>4</sub>	5 <sup>5</sup> / <sub>16</sub>	4 <sup>15</sup> / <sub>16</sub>	<sup>1</sup> / <sub>8</sub>	11 <sup>11</sup> / <sub>16</sub>	10 <sup>3</sup> / <sub>8</sub>	10 <sup>3</sup> / <sub>16</sub>	4 <sup>15</sup> / <sub>16</sub>	2 <sup>1</sup> / <sub>16</sub>	5 <sup>5</sup> / <sub>8</sub>	<sup>1</sup> / <sub>2</sub>	
15 <sup>5</sup> / <sub>16</sub>	7 <sup>3</sup> / <sub>8</sub>	1 <sup>3</sup> / <sub>4</sub> x <sup>7</sup> / <sub>8</sub>	8 <sup>3</sup> / <sub>8</sub>	1 <sup>3</sup> / <sub>4</sub> x <sup>5</sup> / <sub>8</sub>	15 <sup>5</sup> / <sub>16</sub>	8 <sup>1</sup> / <sub>2</sub>	6 <sup>1</sup> / <sub>32</sub>	5 <sup>11</sup> / <sub>16</sub>	<sup>3</sup> / <sub>16</sub>	13 <sup>3</sup> / <sub>32</sub>	11 <sup>3</sup> / <sub>8</sub>	11 <sup>3</sup> / <sub>8</sub>	5 <sup>1</sup> / <sub>16</sub>	2 <sup>1</sup> / <sub>4</sub>	5 <sup>3</sup> / <sub>4</sub>	<sup>1</sup> / <sub>2</sub>	
16 <sup>3</sup> / <sub>16</sub>	8 <sup>3</sup> / <sub>4</sub>	2 x 1	9 <sup>1</sup> / <sub>4</sub>	2 x <sup>3</sup> / <sub>4</sub>	16 <sup>3</sup> / <sub>16</sub>	9	6 <sup>5</sup> / <sub>8</sub>	6 <sup>1</sup> / <sub>16</sub>	<sup>3</sup> / <sub>16</sub>	14 <sup>1</sup> / <sub>2</sub>	12 <sup>3</sup> / <sub>8</sub>	12 <sup>1</sup> / <sub>2</sub>	5 <sup>15</sup> / <sub>16</sub>	2 <sup>9</sup> / <sub>16</sub>	6 <sup>1</sup> / <sub>4</sub>	<sup>1</sup> / <sub>2</sub>	
18	9 <sup>3</sup> / <sub>8</sub>	2 x 1	9 <sup>3</sup> / <sub>8</sub>	2 x <sup>3</sup> / <sub>4</sub>	18	10	7 <sup>13</sup> / <sub>32</sub>	7 <sup>5</sup> / <sub>32</sub>	<sup>3</sup> / <sub>16</sub>	16 <sup>7</sup> / <sub>16</sub>	13 <sup>3</sup> / <sub>8</sub>	13 <sup>1</sup> / <sub>2</sub>	6 <sup>7</sup> / <sub>16</sub>	2 <sup>11</sup> / <sub>16</sub>	7	<sup>1</sup> / <sub>2</sub>	
20 <sup>1</sup> / <sub>4</sub>	10 <sup>1</sup> / <sub>4</sub>	2 <sup>1</sup> / <sub>2</sub> x 1 <sup>1</sup> / <sub>4</sub>	11 <sup>1</sup> / <sub>2</sub>	2 <sup>1</sup> / <sub>2</sub> x <sup>7</sup> / <sub>8</sub>	20 <sup>1</sup> / <sub>4</sub>	12	8 <sup>1</sup> / <sub>16</sub>	8 <sup>1</sup> / <sub>16</sub>	<sup>3</sup> / <sub>16</sub>	19 <sup>3</sup> / <sub>16</sub>	15 <sup>1</sup> / <sub>4</sub>	15 <sup>1</sup> / <sub>4</sub>	6 <sup>15</sup> / <sub>16</sub>	2 <sup>15</sup> / <sub>16</sub>	7 <sup>1</sup> / <sub>2</sub>	<sup>1</sup> / <sub>2</sub>	

Dimensions in inches.

# Custom Spindles and Design Variations

Amerigear spindles can be specifically designed for custom applications and unconventional requirements. Ameridrives provides years of engineering experience, modern manufacturing facilities, and advanced computer analysis capability to design and manufacture spindles to meet your rolling mill needs.

The following illustrations show examples of custom Amerigear Flexible Spindle designs. Contact Ameridrives Couplings to discuss the spindle selection for your custom application.

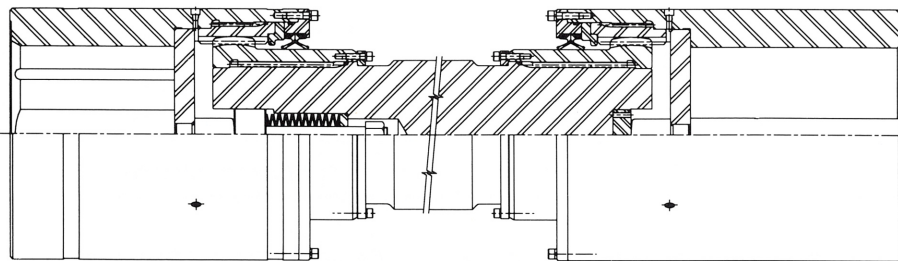

**HOT STRIP MILL SPINDLE**

## SM 23-5/8

- Finish Stands
- 2,480 HP @ 59 RPM
- Misalignment – 1-1/2° Full Load; 4° No Load
- 23-5/8" Diameter Roll End and Pinion End Adapters
- Replaceable Gear Elements
- Splined Hubs
- Roll End Spring Thrust Package
- Developed Roll End Adapter Bore
- Carburized Gearing

## SM 14/18

- 3 Stand
- 2,000 HP @ 125 RPM
- Misalignment – 1-1/2° Full Load; 2° No Load
- 14" Diameter Roll End Adapter
- 18" Diameter Pinion End Adapter
- Replaceable Insert Gear Ring at Pinion End
- Replaceable Roll End Spindle Keys
- Splined Hubs
- Roll End Spring Thrust Package
- Induction Hardened Gearing

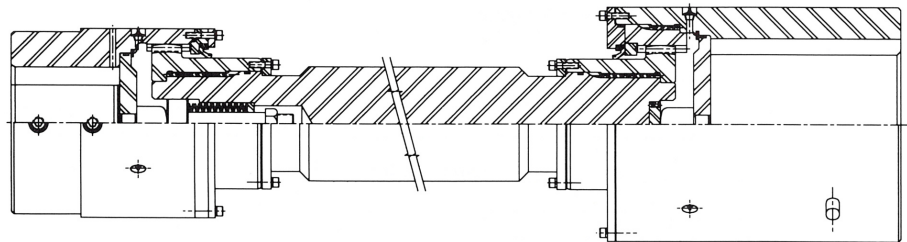

**TANDEM COLD MILL SPINDLE**

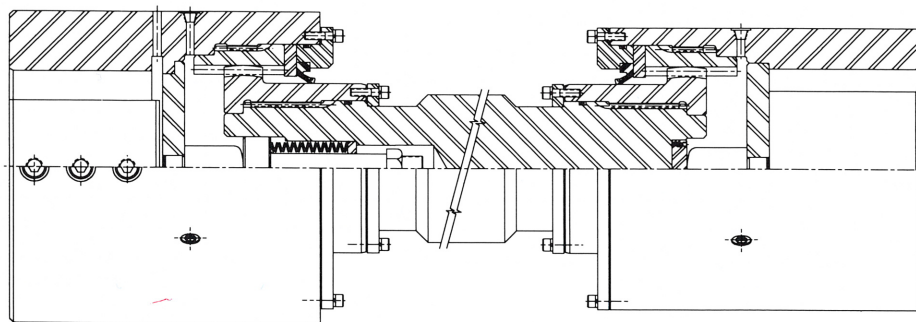

**TEMPER MILL SPINDLE**

## SM 21/16

- Single Stand Cold Mill
- 300 HP @ 29 RPM
- Misalignment – 3° Full Load; 4° No Load
- 21" Diameter Roll End Adapter
- 16" Diameter Pinion End Adapter
- Replaceable Gear Elements
- Replaceable Roll End Spindle Keys
- Splined Hubs
- Roll End Spring Thrust Package
- Induction Hardened Gearing



# Custom Spindles and Design Variations

## SM 16-1/2

Single Stand Cold Mill  
 1,500 HP @ 350 RPM  
 Misalignment – 1-1/2° Full Load; 3° No Load  
 16-1/2" Diameter Roll End and Pinion End  
 Adapters  
 Replaceable Gear Elements  
 Replaceable Roll End Spindle Keys  
 Splined Hubs  
 Roll End Spring Thrust Package  
 Induction Hardened Gearing

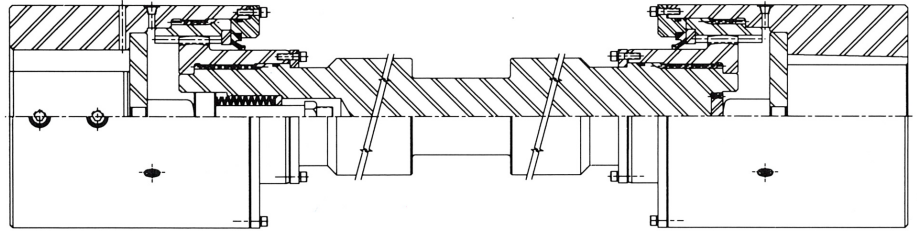

**TIN MILL SPINDLE**

## SM 11-1/2/18

2,000 HP @ 350 RPM  
 Misalignment – 2° Full Load and No Load  
 11-1/2" Diameter Roll End Sleeve  
 18" Diameter Pinion End Adapter  
 Replaceable Insert Gear at Pinion End  
 Replaceable Roll End Spindle Keys  
 Splined Hub at Roll End  
 ±3-1/2" Axial Travel for Roll Shifting  
 Roll End Spring Thrust Package  
 Carburized Gearing

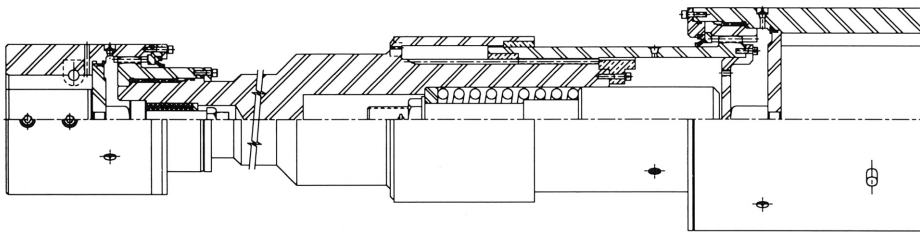

**TANDEM COLD MILL SPINDLE**

## SF 8-3/8/SM 8-3/4

75 HP @ 131 RPM  
 Misalignment – 3/4° Full Load; 1-1/2° No Load  
 8-3/4" Diameter Roll End Sleeve  
 8-3/8" Diameter Pinion End Flange Sleeve  
 Roll End Quick Disconnect  
 Induction Hardened Gearing

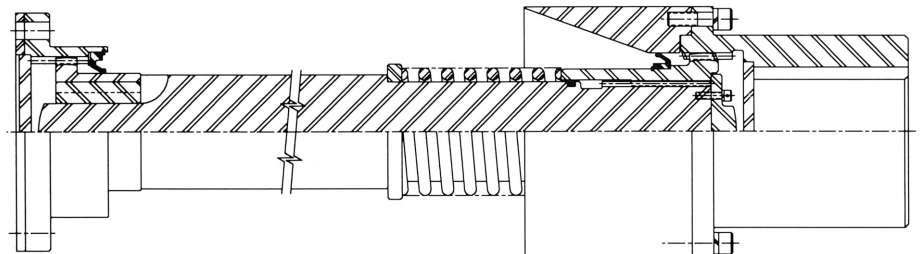

**SLITTER SPINDLE**

## SM 7-13/16/6-5/8

875 HP @ 280 RPM  
 Misalignment – 1/2° Full Load; 1° No Load  
 6-5/8" Diameter Roll End Sleeve  
 7-13/16" Diameter Pinion End Sleeve  
 Special Notched Roll End Sleeve  
 Nitrided Gearing

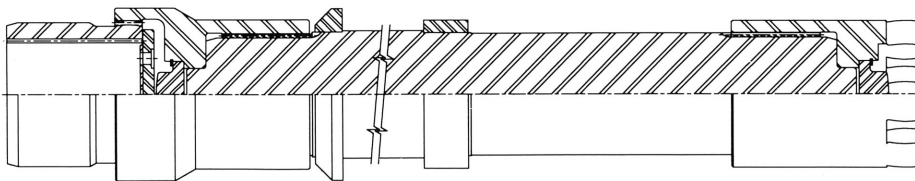

**CLUSTER COLD MILL (Z MILL) SPINDLE**

# Typical Applications

Whatever the application, there is an Amerigear Spindle design to meet your specific requirements. Following is a list of Amerigear Spindle applications.

## SM Spindles

### Metal Industry - Main Drives

(Steel, Aluminum, Copper, Brass)

- Bar and Rod Mills
- Cold Mills
- Continuous Casters
- Hot Strip Mills
- Pipe Mills
- Reversing Roughers
- Scalebreakers
- Sendzimir Mills
- Structural Mills
- Temper Mills
- Tube Mills
- Wire Mills

### SL and SF Spindles

Agitators

Blowers and Fans

Compressors

Conveyors

Cranes and Hoists

Crushers

Dredges

Food Industry

- Grain Mills
- Sugar Mills

## Generators

### Glass Manufacturing

### Lumber Industry

- Barkers
- Hoists
- Planer Tilting Hoist
- Sorting Table
- Trimmer Feed

### Marine Propulsion

### Metal Industry - Auxiliary Drives

(Steel, Aluminum, Copper, Brass)

- Bridles
- Brush Rolls
- Coilers
- Downcoilers
- Feed Rolls
- Flatteners
- Levelers
- Loopers
- Payoff Reels
- Pinch Rolls
- Rotary Side Guides
- Runout Tables
- Shears
- Side Trimmers
- Slitters
- Straighteners
- Tension Reels
- Transfer Cars
- Trimmers
- Unwinders
- Winders

### Mining Equipment

### Oil and Gas

- Chillers
- Drilling Rigs
- Pumps
- Rotary Kilns

## Packaging

### Paper Mill Machinery

- Calender Rolls
- Couch Rolls
- Dryers
- Presses
- Process Pumps
- Reels
- Refiners
- Sizing Rolls
- Slitters
- Suction Rolls
- Winders

### Plastic Manufacturing

- Calenders
- Melt Pumps

### Printing Presses

### Pumps

- Irrigation
- Lift
- Sewage

### Rubber

- Banbury Mixers
- Calenders
- Sheeters
- Straighteners
- Tubers

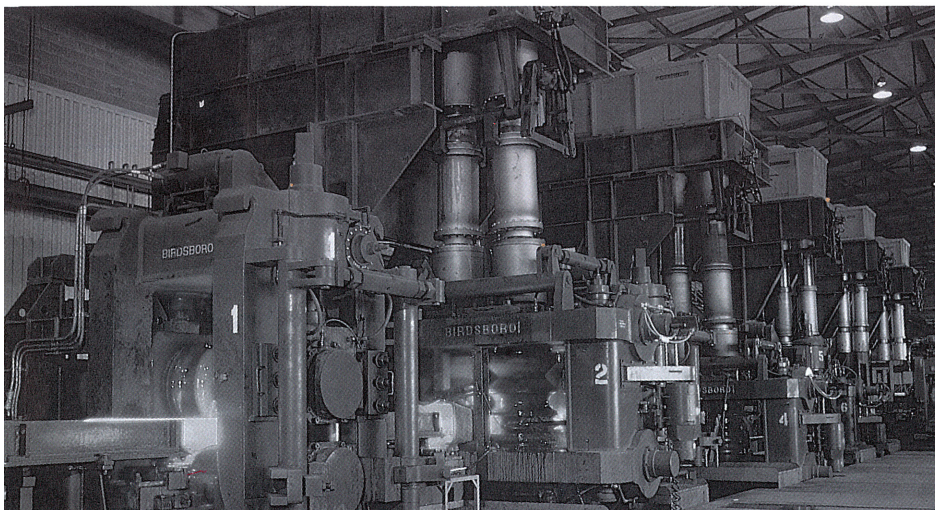

Amerigear SM Spindles on Bar Mill Vertical Stand

## Rolling Mill Application Data for Selection and Design

Customer: \_\_\_\_\_ Inquiry No.: \_\_\_\_\_  
 Contact Name: \_\_\_\_\_ No. of Units: \_\_\_\_\_  
 Type of Mill: \_\_\_\_\_ Phone: \_\_\_\_\_  
 No. of Stands: \_\_\_\_\_ Fax: \_\_\_\_\_  
 Date: \_\_\_\_\_ No. of Pages \_\_\_\_\_  
 (including cover sheet)

Fill in the boxes on the diagrams below for the following information.

- |                              |   |   |
|------------------------------|---|---|
| 1. Motor Horsepower          | 6. Pinion Centers                         | 11. Maximum Work Roll Centers - Operating |
| 2. Motor RPM (Min. and Max.) | 7. Shaft Separation                       | 12. Maximum Operating Angle (Full Load)   |
| 3. Required Service Factor   | 8. Minimum Work Roll Diameter             | 13. Maximum Roll Change Angle (No Load)   |
| 4. Motor Overload Rating     | 9. Maximum Work Roll Diameter             | 14. Bore Requirements                     |
| 5. Reducer Ratio             | 10. Minimum Work Roll Centers - Operating |   |

Comments or special features (e.g. page 16-17) or special conditions such as: Ambient temperature, atmospheric, diameter limitation, roll change method, bore wear problems, vertical or reversing application, work roll or back up roll driven, torque amplification factor, shaft support, etc.: \_\_\_\_\_

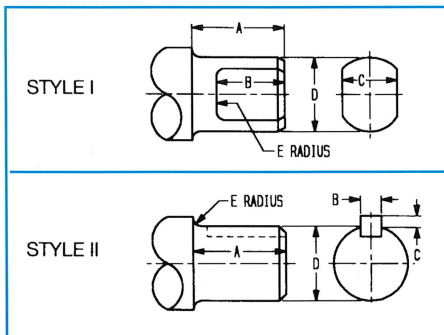
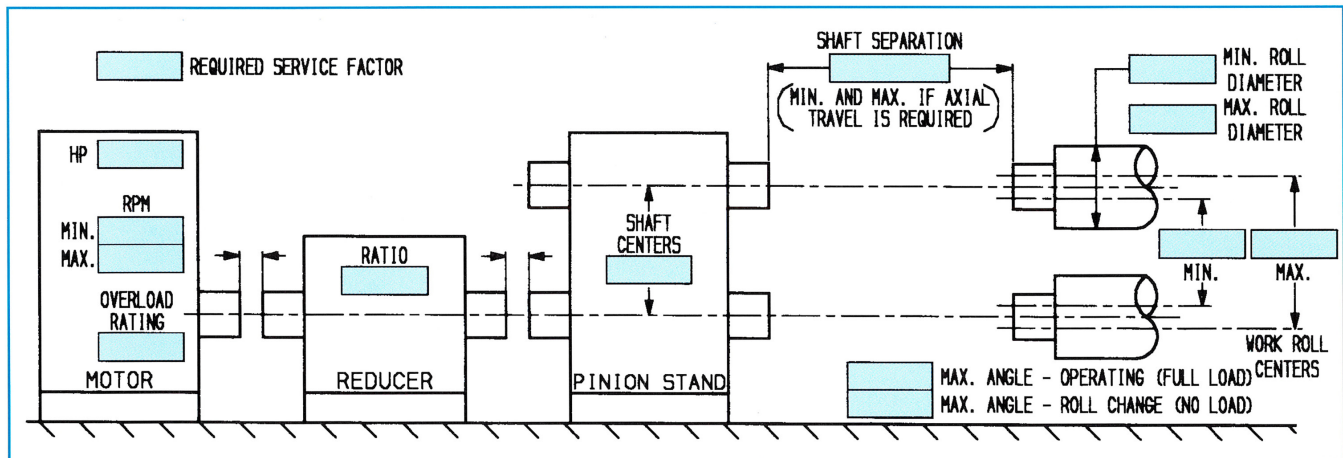

BORE REQUIREMENTS		
STYLE	PINION SHAFT	ROLL NECK
A		
B		
C		
D		
E		

**Caution:**

This product will be selected based on the information supplied to Ameridrives Couplings by the Purchaser. Complete and accurate information will help to minimize errors and misapplications. Further, it is the responsibility of the Purchaser to assure the interface connection between couplings and connected equipment (flanges, bolting, keys, hydraulic fits, ect.), are capable of handling anticipated loads. Ameridrives Couplings will not be responsible for errors due to inaccurate or incomplete information supplied to Ameridrives Couplings.

All Customer Service phone numbers shown in bold

## Electromagnetic Clutches and Brakes

### Warner Electric

*Electromagnetic Clutches and Brakes*

New Hartford, CT - USA  
**1-800-825-6544**

*For application assistance:*  
1-800-825-9050

St Barthelemy d'Anjou, France  
**+33 (0) 2 41 21 24 24**

*Precision Electric Coils and Electromagnetic Clutches and Brakes*

Columbia City, IN - USA  
**1-260-244-6183**

### Matrix International

*Electromagnetic Clutches and Brakes, Pressure Operated Clutches and Brakes*

Brechin, Scotland  
**+44 (0) 1356 602000**

New Hartford, CT - USA  
**1-800-825-6544**

### Inertia Dynamics

*Spring Set Brakes; Power On and Wrap Spring Clutch/Brakes*

New Hartford, CT - USA  
**1-800-800-6445**

## Linear Products

### Warner Linear

*Linear Actuators*  
Belvidere, IL - USA  
**1-800-825-6544**

*For application assistance:*  
1-800-825-9050

St Barthelemy d'Anjou, France  
**+33 (0) 2 41 21 24 24**

## Couplings

### Ameridrives Couplings

*Mill Spindles, Ameriflex, Ameridisc*

Erie, PA - USA  
**1-814-480-5000**

*Gear Couplings*

San Marcos, TX - USA  
**1-800-458-0887**

### Bibby Turboflex

*Disc, Gear, Grid Couplings, Overload Clutches*

Dewsbury, England  
**+44 (0) 1924 460801**

Boksburg, South Africa  
**+27 11 918 4270**

### TB Wood's

*Elastomeric Couplings*

Chambersburg, PA - USA  
**1-888-829-6637** – Press #5

*For application assistance:*  
1-888-829-6637 – Press #7

*General Purpose Disc Couplings*

San Marcos, TX - USA  
**1-888-449-9439**

### Ameridrives Power Transmission

*Universal Joints, Drive Shafts, Mill Gear Couplings*

Green Bay, WI - USA  
**1-920-593-2444**

### Huco Dynatork

*Precision Couplings and Air Motors*

Hertford, England  
**+44 (0) 1992 501900**

Chambersburg, PA - USA  
**1-888-829-6637**

### Lamiflex Couplings

*Flexible Couplings, Bearing Isolators, and Coupling Guards*

São Paulo, SP - Brasil  
**(11) 5679-6533**

## Heavy Duty Clutches and Brakes

### Wichita Clutch

*Pneumatic Clutches and Brakes*

Wichita Falls, TX - USA  
**1-800-964-3262**

Bedford, England  
**+44 (0) 1234 350311**

### Twiflex Limited

*Caliper Brakes and Thrusters*

Twickenham, England  
**+44 (0) 20 8894 1161**

### Industrial Clutch

*Pneumatic and Oil Immersed Clutches and Brakes*

Waukesha, WI - USA  
**1-262-547-3357**

## Gearing

### Boston Gear

*Enclosed and Open Gearing, Electrical and Mechanical P.T. Components*

Charlotte, NC - USA  
**1-800-825-6544**

*For application assistance:*  
1-800-816-5608

### Bauer Gear Motor

*Gearred Motors*

Esslingen, Germany  
**+49 (711) 3518 0**

Somerset, NJ - USA  
**1-732-469-8770**

### Nuttall Gear and Delroyd Worm Gear

*Worm Gear and Helical Speed Reducers*

Niagara Falls, NY - USA  
**1-716-298-4100**

## Overrunning Clutches

### Formsprag Clutch

*Overrunning Clutches and Holdbacks*

Warren, MI - USA  
**1-800-348-0881** – Press #1

*For application assistance:*  
1-800-348-0881 – Press #2

### Marland Clutch

*Roller Ramp and Sprag Type Overrunning Clutches and Backstops*

South Beloit, IL - USA  
**1-800-216-3515**

### Stieber Clutch

*Overrunning Clutches and Holdbacks*

Heidelberg, Germany  
**+49 (0) 6221 30 47 0**

## Belted Drives and Sheaves

### TB Wood's

*Belted Drives*

Chambersburg, PA - USA  
**1-888-829-6637** – Press #5

*For application assistance:*  
1-888-829-6637 – Press #7

## Engineered Bearing Assemblies

### Kilian Manufacturing

*Engineered Bearing Assemblies*

Syracuse, NY - USA  
**1-315-432-0700**

For information concerning our sales offices in Asia Pacific check our website  
[www.altramotion.com.cn](http://www.altramotion.com.cn)



[www.ameridrives.com](http://www.ameridrives.com)

1802 Pittsburgh Avenue  
Erie, PA 16502 - USA  
814-480-5000  
Fax: 814-453-5891



SOCIEDAD INDUSTRIAL DE TRANSMISIONES S.A.

Pº Ubarburu, 67  
20014 San Sebastián

Tfno. 943 457200

Fax 943 463356

[www.sitsa.es](http://www.sitsa.es)

[atencioncliente@sitsa.es](mailto:atencioncliente@sitsa.es)