

Amerigear® Gear Couplings

High Speed, High Performance Design

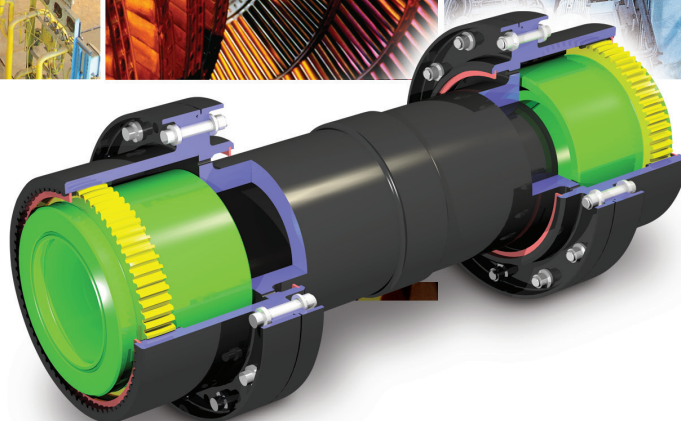
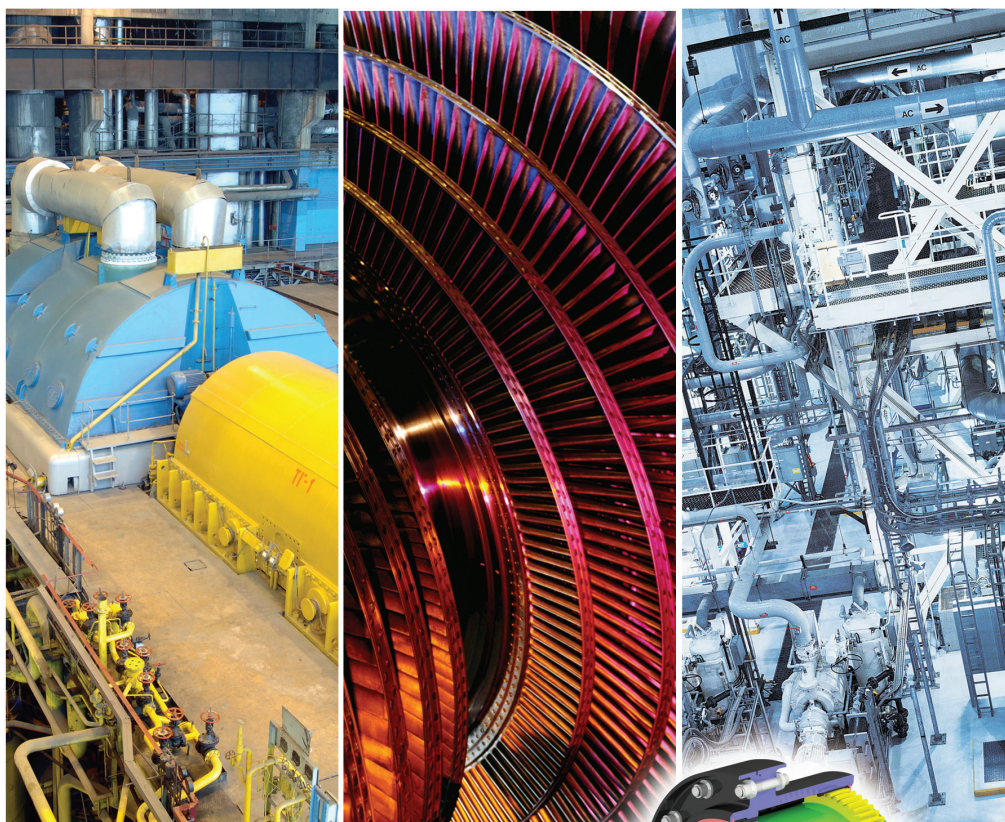

 **Ameridrives®**
Couplings

An Altra Industrial Motion Company





Amerigear® high performance Class I Gear Couplings Introduction, Design and Manufacturing

Amerigear High Performance Class I Gear Coupling

Higher torque, higher speed, and higher misalignment requirements; this is the trend in rotating mechanical equipment. Let Ameridrives Couplings, first to apply the Fully Crowned Tooth concept to a gear-type coupling in the early 1950's, supply a coupling for your needs. Our engineering know-how in tooth design, material and lube selection, and manufacturing techniques stand ready to serve you.

We can supply you with one of our conventional Class 1 high performance designs, or let us custom-design a coupling for your equipment.

If you need to connect two or more pieces of rotating equipment – contact Ameridrives.

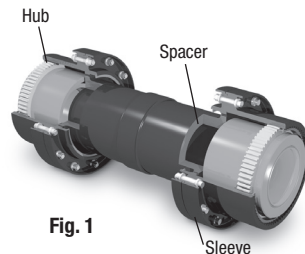

Fig. 1

Conventional Class I Designs

Amerigear Class I High Performance Gear Couplings are compact, offering high torque and high performance characteristics in relation to their size and weight.

The standard line is rated at full 1/4° misalignment per gear mesh. The hubs, sleeves, and spacer are made of high quality AISI 4140 heat treated steel with nitrided gear teeth, providing optimum strength and hardness properties. Fasteners are twelve point Grade 8 bolts and matching self-locking nuts.

The gear tooth is fully crowned. The flanks of the teeth are crowned so that the tooth thickness is greatest at the center of the tooth.

This assures larger contact area per tooth for higher court capacity and puts more teeth in contact at a given angle. The crowned flank eliminates end-of-tooth loading, provides optimum load distribution, and corrects for all types of misalignment with minimum backlash.

Tips of the teeth are crowned with a radius equal to the outside radius of the gear element. The crowned tip contacts the root of the internal gear teeth in the external sleeve, accurately piloting the sleeve and permitting minimum diametral sleeve clearance to assure good dynamic balance characteristics.

Faces of the teeth adjacent to the tips are crown chamfered to eliminate interference with sleeve tooth fillets, allowing true involute flanks of gear teeth to be in contact with the sleeve tee regardless of operating angle.

Custom High Performance Designs

These couplings are custom-designed to your needs, whether they involve weight or size

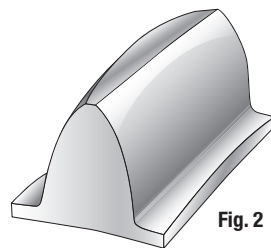

Fig. 2

limitations, high temperature, high speed, or extreme misalignment requirements. We would select a material suitable for your application from a variety of choices including 1045, 4140 Nitrided, 4340 Nitrided, Nitr alloy, 8620 or 9310 carburized.

Fastener selection again would be dependent on your requirements. They could be Grade 5, Grade 8, Aircraft type, Inconel, etc.

Tooth design would be fully crowned and specifically designed to your needs which could be as high as 7-1/2° per mesh. Coupling balance would also be based on your requirements.

Conventional Class I Manufacturing

Amerigear couplings are manufactured to precise tolerances. Tips of external gear teeth are spherically ground for a precision fit with mating internal sleeve teeth. All other pilots utilize interference fits.

Gear teeth are manufactured by precision hobbing and shaping equipment to exacting standards of tooth finish, profile, and spacing. All parts are magnetic particle inspected to assure soundness and reliability.

Balancing is performed by components on sensitive balancing machines to assure smooth, vibration-free operation of the installed coupling.

Parts are heat-treated to controlled specifications to provide maximum strength and coupling life.

Custom High Performance Manufacturing

All the standard practices used to manufacture our conventional Class I couplings are used, plus any special requirements deemed necessary for a specific application including material property tests, ultrasonic tests, 100% inspection, assembly check balancing, etc.

API-671 Specification

Class I Amerigear couplings can optionally be built to comply with API-671.

Ameridrives International
Coupling Products



Coupling Selection and Order Information

1. Obtain shaft sizes.

Compare shaft sizes of driving and driven equipment with maximum bores listed on page 4 to determine tentative coupling size.

2. Compute effective torque to be transmitted. Select service factor from the adjacent table. Determined design torque as follows:

$$\text{Torque} = \frac{\text{horsepower} \times 63025 \times \text{S.F.}}{\text{RPM}}$$

Check torque ratings on page 6 and confirm coupling size, or increased to a size with a torque rating equal to or greater than design torque.

3. Check maximum speed of coupling.

Find the curve on page 6 appropriate to the size and style selected. Knowing the required shaft separation, read the approximate maximum operating speed. These speeds are given only as a guide, since the maximum speed depends on system characteristics.

4. Check space limitations.

Dimensions of the selected coupling should be compared with the space provided in the application to assure proper clearances. Shaft extensions, separation, and clearance to align coupling should be considered.

Example:

A steam turbine rated at 10,500 HP is to drive a centrifugal compressor at 7800 rpm. Shaft sizes are 4" for the turbine and 3.5" for the compressor, both incorporating (2) standard AGMA reduced keys. Shaft separation is 24" and continuous lubrication is desired. On the basis of the 4" bore, a size 103 is selected.

$$\begin{aligned} \text{Torque} &= \frac{10500 \times 63025 \times 1.0}{7800} \\ &= 84841 \text{ in.lb.} \end{aligned}$$

The maximum torque for a 103 continuous lube coupling is 115,000 in.lb. The maximum speed at 24" shaft separation is about 11,000 rpm. Therefore, a 103 FELE coupling is suitable for this application.

Coupling Series Designations

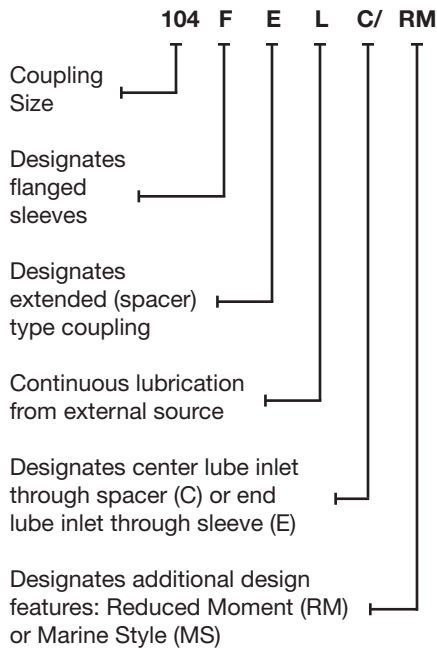

Note: In accordance with our established policy to constantly improve our products, the specifications contained herein are subject to change without notice.

When ordering, specify the following information:

1. Shaft or bore sizes, keyway dimensions, and hub lengths. Give exact sizes with tolerances.
2. Load—horsepower and/or torque at a specific rpm. State normal (steady-state) and peak (transient) conditions.
3. Speed—minimum, normal, and maximum.
4. Application—type of driving and driven equipment.
5. Space limitations—envelope dimensions, shaft extensions, and shaft separation.
6. Unusual misalignment conditions, normal and maximum.
7. Modifications and special requirements.
8. Unusual operating conditions—ambient temperature and atmosphere.
9. Quantity and delivery requirements.

Note: If you need more information or assistance when selecting a coupling, contact Ameridrives Couplings.

Service Factors

Load	Driven Equipment	Type Driver		
		Motor or Turbine	Steam Engines Water Turbines	Reciprocating Engines
Constant Torque	Centrifugal Pumps and Compressors; Conveyors, Generators, Light Fans	1.00	1.25	1.50
Slight Torque Fluctuations	Machine Tools, Large Fans, Screw Compressors and Pumps	1.50	1.75	2.00
Sub-Stantial Torque Fluctuations	Reciprocating Compressors, Marine Drive Shafts, Mill Drives	1.75	2.00	2.50

Caution: Surface factors applied incorrectly will increase coupling size and weight unnecessarily. Service factors should be applied to lower of two torque ratings of driver or driven equipment. If coupling selection with service factor is too heavy or large, consult Ameridrives Couplings. Factors should be applied to normal operating torques only.



Bore and Keyway Information

Maximum Bore Data - Series FE, FELE, FE/RM, FELE/RM, FELC/RM

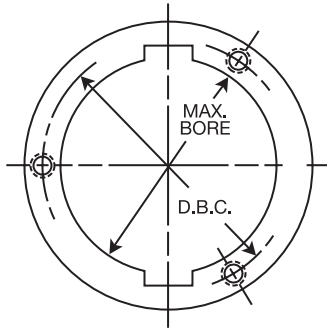

Size	Max. Bore 2 Square Keys	Max. Bore 2 Reduced Keys	Max. Bore Shrink Drive (Keyless)	Max. Bore With Puller Holes	Puller Hole	
					D.B.C	Size
101-¼	1.500	1.688	1.500	1.38	1.75	1/4 - 20
101-½	2.125	2.250	2.000	2.00	2.44	1/4 - 20
102	2.688	2.875	2.500	2.75	3.19	1/4 - 20
102-½	3.062	3.250	3.000	3.12	3.69	3/8 - 16
103	3.750	4.000	3.500	3.88	4.50	3/8 - 16
103-½	4.500	4.688	4.125	4.62	5.31	3/8 - 16
104	5.188	5.500	4.750	5.50	6.25	3/8 - 16
104-½	5.500	5.875	5.125	5.75	6.62	1/2 - 13
105	6.375	6.500	5.875	6.50	7.50	1/2 - 13
105-½	7.125	7.250	6.500	7.00	8.25	1/2 - 13
106	8.000	8.312	7.250	8.00	9.25	5/8 - 11
107	9.000	9.500	8.250	9.50	10.75	5/8 - 11

Notes:

1. Maximum bores for keyed shafts are for standard key sizes and interferences listed below, short hub lengths, and rated sealed lube torques. Maximum bore may be increased in most cases when using longer hubs or transmitting less than rated torque. Maximum bore may have to be decreased when using 1 (one) key or increased interference. Consult Ameridrives Couplings.
2. Maximum bores for shrink drives are based on a bore-to-barrel ratio of 1.45. Actual maximum will be determined by the amount of interference required to achieve the desired torque transmission capability.

Installation and Alignment

The equipment to be coupled must be accurately positioned and aligned to assure maximum coupling life. It is recommended that “cold” misalignment not exceed 1/3 of rated misalignment capacity. This allows for errors and calculated misalignment or unexpected movements of equipment throughout the life of the coupling.

Alignment checks should be taken on hub surfaces as shown in Fig. 1 (page 2).

For continuously lubed couplings, two lube nozzles at 180° are recommended. Oil supply tubes should be designed to maintain a flow rate of approximately 8 feet per second. Orifices should be designed to produce a minimum exit velocity of 20 feet per second. See Fig. 3 (page 5) for lube flow rate requirements.

For sealed lube couplings, a sufficient quantity of oil or grease should be used so that during operation, an annulus is maintained at least 1/4" below the gear minor diameter. This quantity is listed to the right, and is called out on our sales drawings.

Observe the following precautions:

1. Do not interchange coupling components with those of similar assemblies, since hub tooth tips are mated to matching sleeves. Bolt holes are line reamed and are not interchangeable.
2. Fasteners should be replaced after being assembled and disassembled a maximum of 10 times.
3. Tighten flange nuts to the correct torques as shown in the chart below.

Size	Oil Capacity per Mesh For Seales Lube Couplings			
	FE		FE/RM	
	Pints	Lb.	Pints	Lb.
101-¼	.03	.03	.05	.05
101-½	.05	.05	.09	.08
102	.08	.07	.17	.16
102-½	.09	.09	.21	.20
103	.15	.14	.39	.37
103-½	.22	.21	.70	.66
104	.27	.25	.93	.87
104-½	.36	.34	1.34	1.26
105	.53	.50	1.92	1.80
105-½	.86	.81	2.86	2.68
106	.84	.79	3.21	3.02
107	1.55	1.46	6.57	6.17

Size	*Nut Tightening Torque (Dry) In. - Lbs.	Flange Bolts		
		Qty.	Size	DBC
101-¼	125	6	1/4-28	3.875
101-½	250	6	5/16-24	4.812
102	450	8	3/8-24	5.75
102-½	450	8	3/8-24	6.75
103	450	10	3/8-24	7.937
103-½	450	12	3/8-24	8.937
104	1000	10	1/2-20	10.375
104-½	1000	12	1/2-20	11.375
105	1000	16	1/2-20	12.375
105-½	1000	18	1/2-20	13.375
106	1000	18	1/2-20	14.375
107	2100	18	5/8-18	16.625

*Decrease tightening torque to 75% of values when threads are lubricated.



Lubrication Comparison Data Sealed vs. Continuous

Gear-type couplings may be continuously-lubricated, or may be filled with a specific quantity of lubricant and sealed. There are many factors governing which method should be chosen, and each coupling application must be evaluated with respect to its particular requirements. Some factors to be considered are listed at right. Generally, where application parameters do not demand continuous lubrication, a sealed unit is the preferred choice. If an application is being considered where the best method of lubrication is not easily determined, please consult the factory.

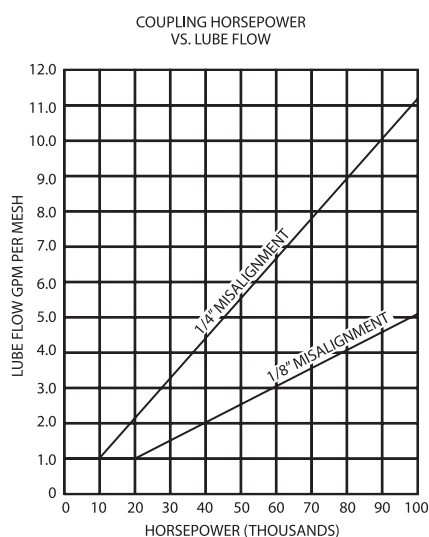

Fig. 3

Sealed Lube

1. Affords the opportunity to choose the best lubrication available.
2. Outside contaminants effectively prohibited from entering working gears.
3. Case design is simplified – not required to be an oil-tight enclosure.
4. Coupling may operate for extended periods of time without servicing, other than the normal leakage checks.
5. In disconnect type couplings, there is a definite limit for maximum differential speed, due to seal rubbing.
6. Seals are required in connected equipment.
7. Seals tend to wear and age. Replacement is not always easy.
8. High ambient temperatures may adversely affect the lubricant.

Since there is no universal agreement as to what high speed really is, there are no universal answers and recommendations concerning high-speed lubrication. Ambient temperature, coupling alignment, tip clearance, and duty cycle are all important variables. Should packed lubrication seem to be the proper method of lubrication, it is generally conceded that a fluid lubricant is the best choice, as grease tends to separate and lose its effectiveness due to the high centrifugal force acting on its various ingredients at high rotational speed. Some oils which have operated satisfactorily at high speed include Nuto No. 146 Humble Oil, Lubriplate No. 8 by Fiske Brothers, Transmission Oil No. 140 by Continental and Gearup No. 140 by Standard Oil of Ohio. Viscosity of these oils range from 2100 to 3600 SUS @ 100°F. An oil which conforms to MIL-L-2105 gr. 140 is acceptable.

In cases where the customer prefers to use a grease lubricant, it is essential that the choice of grease be made carefully, since only a few greases have been formulated and tested at conditions which impose very high centrifugal force on them. Generally, any grease-packed Class I coupling operating over 5000 rpm should be packed with a special high-speed grease. Specialized synthetic greases have been used very successfully including Anderol 786 by Tenneco Chemical, Syn-Tech 3913-G1 and Amoco coupling grease.

Continuous Lube

1. Permits continuous operation but requires periodic sludge removal.
2. Permits high differential speed in disconnect type couplings.
3. Removes generated heat effectively and increases coupling life significantly in applications subject to high ambient temperature conditions.
4. May eliminate the need for costly seals and connected equipment.
5. Eliminates seals in the coupling itself.
6. Does not permit the choice of best lubricating oils.
7. Requires oil supply filtration to 5 micron or less absolute particle size.
8. Requires an oil tight case.

Amerigear Class I Continuously-Lubricated Flexible Couplings have a differential level between inlet and outlet to assure positive oil flow. Design provides for retention of oil in event of pump failure or intermittent-type lubrication. Two lube nozzles at 180° are recommended to assure uniform oil input and distribution. Lubricant should be a high quality, stable petroleum oil with a suitable, noncorrosive load-carrying additive. Viscosity should be a minimum of 50 SUS at 180°F. An oil which conforms to MIL-L-17331 is satisfactory. Couplings using inlet through spacer flange have oil receiver cavities which not only assure uniform distribution but also serve as accumulators for centrifuged deposits. These couplings also incorporate anti-sludge discharge holes in the sleeves, which are designed to maintain a positive lube flow to minimize sludge buildup. See Fig. 4.

In the presence of such contributing factors as high temperature, coarse filtration, low volume, free air circulation, moisture and so on, it is inevitable that sludge and oxidized particles will accumulate in the coupling sleeves. Periodic cleaning is absolutely mandatory. The frequency varies for each installation. As a precaution, within two to three months of initial operation, high speed couplings should be checked for sludge. Future maintenance should be based on the residue found at that time.

Torque and Balancing Data

Torque Ratings

Coupling torque capacity is given at full 1/4° misalignment per gear mesh. When operating at 1/8°, the normal torque capacity of gearing is 7% greater than the values shown.

Apply correct service factor as shown on page 3. If higher torque capacity is required and the size is restricted, consult Ameridrives.

Balancing Procedure

(Standard Balance): All sleeves, hubs and other short parts are single-plane balanced. Spacers and other long parts are two-plane balanced. Fasteners are weigh-balanced in sets, i.e. all fasteners of the same size for one coupling are balanced together. Balancing is accomplished by metal removal.

Each component is balanced so that the level of residual unbalance for each plane does not exceed the greatest value determined by the following:

$$U = 4W/N$$

$$U = .0008 W$$

$$U = .01$$

Where:

U = Residual unbalance (ounce-inches)
 W= Weight of component (pounds),
 apportioned per balance plane
 N = Maximum continuous operating speed (revolutions per minute)

Size	Coupling Torque Capacity, in.-lb.		
	Normal		Peak
	Continuous Lube	Sealed Lube	Continuous & Sealed Lube
101-1/4	9,500	12,000	30,000
101-1/2	22,000	28,500	67,000
102	45,000	50,500	138,000
102-1/2	71,000	81,000	240,000
103	115,000	136,000	400,000
103-1/2	172,000	210,000	548,000
104	245,000	310,000	910,000
104-1/2	350,000	436,000	1,200,000
105	475,000	590,000	1,750,000
105-1/2	620,000	780,000	2,000,000
106	720,000	950,000	2,500,000
107	1,000,000	1,375,000	4,000,000

Speed Ratings

Speeds - General

The graph in Fig. 4 shows maximum operating speeds for all "F" series Amerigear Flexible Couplings. This may be used as a preliminary guide when selecting a coupling. Contact Ameridrives for information on other Amerigear series.

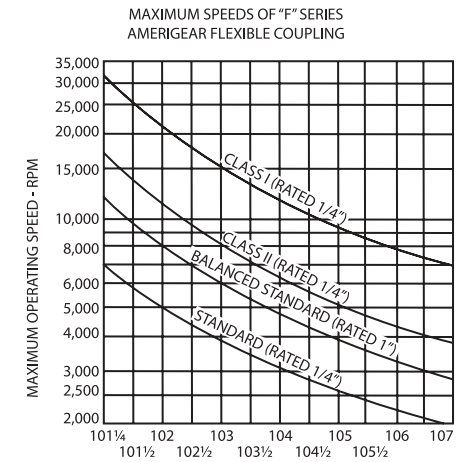

Fig. 4 COUPLING SIZE

Speeds - Class I

The speed limits shown above are only a guide and are based on average system characteristics.

Gear couplings are part of a drivetrain system. If a system is very rigid and stiff, then the maximum speed might be increased, or if a system is soft and has a long shaft overhang, then it may be necessary to decrease speed limits.

Whenever possible, a detailed system critical speed analysis should be carried out.



This series of coupling is used for high performance applications requiring high torque, high-speed and/or high misalignment capabilities.

The FE is equipped with positive O-ring seals for retention of oil or grease in sealed-lube applications.

The FELE is designed for continuous type lubrication with lube being fed into coupling at each end and discharging through the spacer. See pages 4-6 for maximum bores, torque ratings, lube requirements, speed limits, and unbalance data.

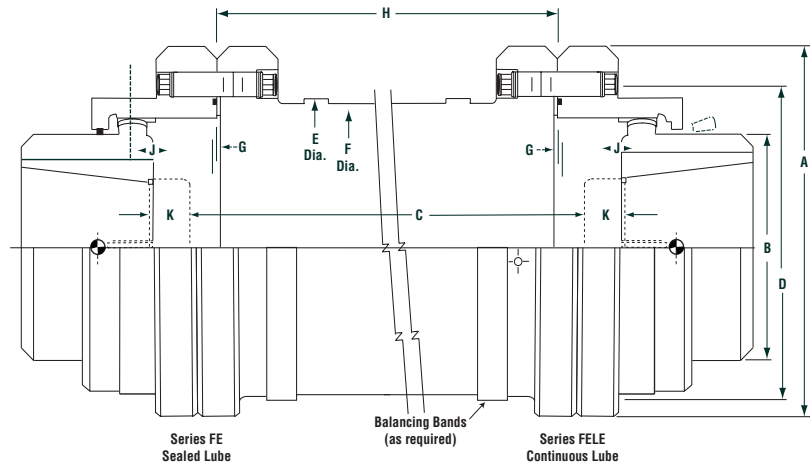

Dimensions (Inches)

Size	A	B	C Minimum	D	E	F	G	H Minimum	J	K
101-¼	4.75	2.12	4.00	3.12	2.66	2.38	.06	3.88	.88	.38
101-½	5.75	2.88	4.25	3.94	3.44	3.12	.06	4.12	.94	.38
102	6.81	3.62	4.25	4.88	4.38	4.00	.09	4.12	1.06	.44
102-½	7.81	4.25	4.31	5.88	5.31	4.84	.09	4.12	1.19	.50
103	9.06	5.12	4.38	7.06	6.38	5.81	.09	4.19	1.31	.56
103-½	10.12	6.00	6.00	8.06	7.25	6.62	.12	5.75	1.44	.62
104	11.75	7.00	6.00	9.31	8.38	7.75	.12	5.75	1.56	.69
104-½	12.75	7.50	6.00	10.25	9.44	8.69	.16	5.69	1.69	.75
105	13.75	8.50	6.00	11.25	10.44	9.69	.16	5.69	2.00	1.00
105-½	14.75	9.50	6.00	12.25	11.44	10.50	.16	5.69	2.25	1.19
106	15.75	10.50	6.00	13.25	12.25	11.25	.16	5.69	2.38	1.25
107	18.25	12.00	6.00	15.25	13.88	12.88	.19	5.62	2.56	1.38

Series FE/MS & FELC/MS

This series of couplings is used for high performance applications requiring high torque, high speed and/or high misalignment capabilities, and where oversize bore capacity or flange-type mounting is required.

The FE/MS is equipped with positive O-ring seals in resilient carriers for retention of oil or grease in sealed-lube applications.

The FELC/MS is designed for continuous type lubrication with lube being fed into coupling at the spacer and discharged at the ends. The exit holes in the rigid hubs provide positive flow and minimize the buildup of deposits. See pages 4-6 for torque ratings, lube requirements, speed limits and unbalance data.

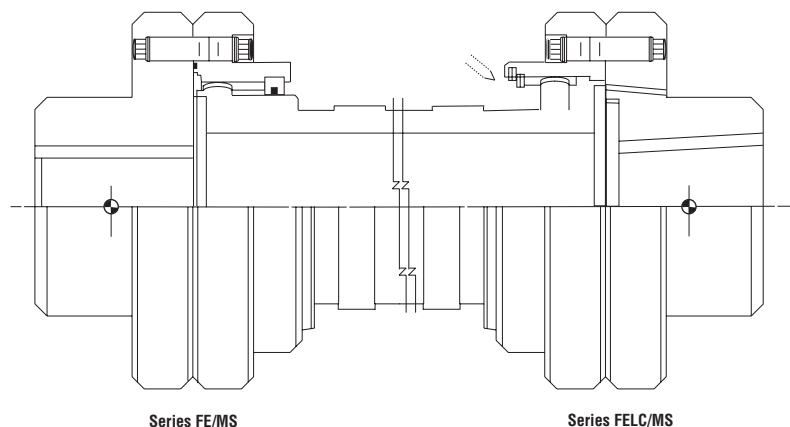

All Customer Service phone numbers shown in bold

Electromagnetic Clutches and Brakes

Warner Electric

Electromagnetic Clutches and Brakes

New Hartford, CT - USA
1-800-825-6544

For application assistance:
1-800-825-9050

St Barthelemy d'Anjou, France
+33 (0) 2 41 21 24 24

Precision Electric Coils and Electromagnetic Clutches and Brakes

Columbia City, IN - USA
1-260-244-6183

Matrix International

Electromagnetic Clutches and Brakes, Pressure Operated Clutches and Brakes

Brechin, Scotland
+44 (0) 1356 602000

New Hartford, CT - USA
1-800-825-6544

Inertia Dynamics

Spring Set Brakes; Power On and Wrap Spring Clutch/Brakes

New Hartford, CT - USA
1-800-800-6445

Linear Products

Warner Linear

Linear Actuators

Belvidere, IL - USA
1-800-825-6544

For application assistance:
1-800-825-9050

St Barthelemy d'Anjou, France
+33 (0) 2 41 21 24 24

Couplings

Ameridrives Couplings

Mill Spindles, Ameriflex, Amerisc

Erie, PA - USA
1-814-480-5000

Gear Couplings

San Marcos, TX - USA
1-800-458-0887

Bibby Turboflex

Disc, Gear, Grid Couplings, Overload Clutches

Dewsbury, England
+44 (0) 1924 460801

Boksburg, South Africa
+27 11 918 4270

TB Wood's

Elastomeric Couplings

Chambersburg, PA - USA
1-888-829-6637 – Press #5

For application assistance:
1-888-829-6637 – Press #7

General Purpose Disc Couplings

San Marcos, TX - USA
1-888-449-9439

Ameridrives Power Transmission

Universal Joints, Drive Shafts, Mill Gear Couplings

Green Bay, WI - USA
1-920-593-2444

Huco Dynatork

Precision Couplings and Air Motors

Hertford, England
+44 (0) 1992 501900

Chambersburg, PA - USA
1-888-829-6637

Lamiflex Couplings

Flexible Couplings, Bearing Isolators, and Coupling Guards

São Paulo, SP - Brasil
(11) 5679-6533

Heavy Duty Clutches and Brakes

Wichita Clutch

Pneumatic Clutches and Brakes

Wichita Falls, TX - USA
1-800-964-3262

Bedford, England
+44 (0) 1234 350311

Twiflex Limited

Caliper Brakes and Thrusters

Twickenham, England
+44 (0) 20 8894 1161

Industrial Clutch

Pneumatic and Oil Immersed Clutches and Brakes

Waukesha, WI - USA
1-262-547-3357

Gearing

Boston Gear

Enclosed and Open Gearing, Electrical and Mechanical P.T. Components

Charlotte, NC - USA
1-800-825-6544

For application assistance:
1-800-816-5608

Bauer Gear Motor

Geared Motors

Esslingen, Germany
+49 (711) 3518 0
Somerset, NJ - USA
1-732-469-8770

Nuttall Gear and Delroyd Worm Gear

Worm Gear and Helical Speed Reducers

Niagara Falls, NY - USA
1-716-298-4100

Overrunning Clutches

Formsprag Clutch

Overrunning Clutches and Holdbacks

Warren, MI - USA
1-800-348-0881 – Press #1

For application assistance:
1-800-348-0881 – Press #2

Marland Clutch

Roller Ramp and Sprag Type Overrunning Clutches and Backstops

South Beloit, IL - USA
1-800-216-3515

Stieber Clutch

Overrunning Clutches and Holdbacks

Heidelberg, Germany
+49 (0) 6221 30 47 0

Belted Drives and Sheaves

TB Wood's

Belted Drives

Chambersburg, PA - USA
1-888-829-6637 – Press #5

For application assistance:
1-888-829-6637 – Press #7

Engineered Bearing Assemblies

Kilian Manufacturing

Engineered Bearing Assemblies

Syracuse, NY - USA
1-315-432-0700

For information concerning our sales offices in Asia Pacific check our website www.altramotion.com.cn



www.ameridrives.com

1802 Pittsburgh Avenue
Erie, PA 16502 - USA
814-480-5000
Fax: 814-453-5891



SOCIEDAD INDUSTRIAL DE TRANSMISIONES S.A.

Pº Ubarburu, 67 - 20014 San Sebastián

Tfn. 943 457200

Fax 943 463356

www.sitsa.es

atencioncliente@sitsa.es