

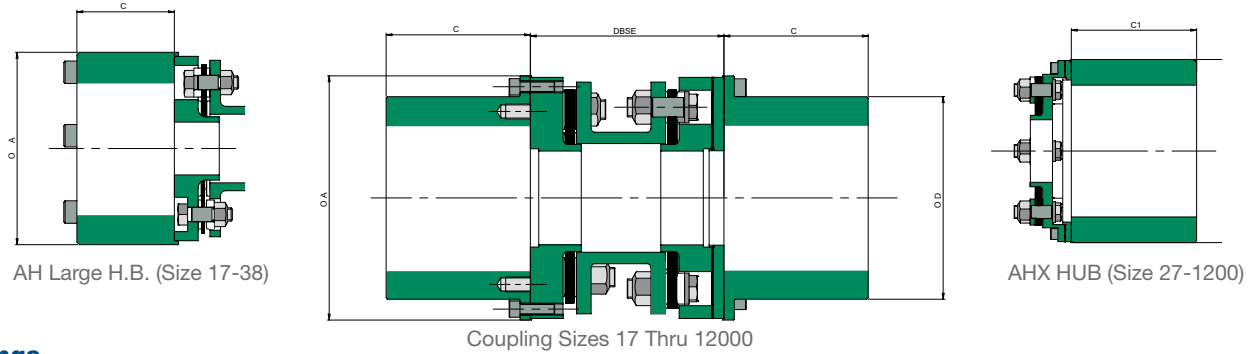

# Torsiflex Disc Couplings for General Purpose & Process Applications

 **Bibby Turboflex**<sup>®</sup>  
Altra Industrial Motion

## COUPLING STYLE SCREW ADAPTER



### TF Ratings

Coupling Size TF	kW/RPM	Rating Nm	MAX SPEED RPM	COUPLING DIMENSIONS						MAX BORE	Mass Unbored (Solid) Hub (Kg)	MAX BORE	Mass Unbored (Solid) Hub (Kg)	MAX BORE	Mass Unbored (Solid) Hub (Kg)	Mass Transmission Unit (Kg)	
				A	A	C	C1	D	Min DBSE mm**							Std. AH Hub	Large AH Hub
17	0.018	170	25000	73	-	37	37	52	70	35	0.7	52	1.2	-	-	0.6	0.02
27	0.028	270	20000	84	101	40	40	60	70	43	1.0	59	1.71	70	2.5	1.34	0.03
38	0.040	380	16500	107	117	45	45	76	70	55	1.8	75	3.05	83	3.8	1.95	0.04
140	0.147	1400	12000	127	154	75	95	101	100	73	4.9	-	-	100	13.8	4.4	0.07
260	0.272	2600	10000	154	176	85	115	121	120	88	7.5	-	-	120	21.6	7.7	0.1
400	0.419	4000	8500	176	208	105	135	144	140	105	13.8	-	-	140	34	12.5	0.14
750	0.785	7500	7500	203	241	120	160	166	170	120	21	-	-	165	56	20.5	0.23
1310	1.37	13100	6500	241	282	145	185	199	200	145	37	-	-	190	89	35	0.27
1900	1.99	19000	5600	279	318	150	210	233	200	170	52	-	-	220	130	46	0.33
2500	2.62	25000	5200	296	348	164	230	240	220	175	61	-	-	240	169	58	0.4
3300	3.46	33000	4900	327	381	182	250	270	240	190	84	-	-	260	220	78	0.49
6000	6.28	60000	4000	395	457	230	310	322	260	230	151	-	-	320	378	123	0.73
7500	7.85	75000	4000	416	457	240	310	336	280	240	172	-	-	320	378	143	0.73
8500	8.90	85000	3600	444	503	262	345	365	320	260	220	-	-	360	532	190	0.96
11500	12.04	115000	3600	476	503	270	345	380	340	270	250	-	-	360	532	228	1.06
12000	12.57	120000	3000	494	556	292	385	410	340	290	311	-	-	400	721	255	1.38
16500	17.28	165000	3000	531	556	300	385	425	360	300	347	-	-	400	721	306	1.38

New Sizes Highlighted

\* Large Hub Boss Diameter. \*\* The inclusion of additional features such as packing rings, shims and/or electrical insulation will increase the minimum DBSE (Distance Between Shaft Ends).

### Torsiflex Coupling Ranges

Specifically designed for the process pump, fan, blowers, compressors and general industrial markets.

- Plug-in design allows rapid installation and ensures that shaft alignment is always maintained.
- Standard couplings fully compliant with the requirements of API 610 / ISO 14691.
- Engineered version compliant with **API 671 / ISO 10441**.
- Incorporates anti-flail feature.
- Large hubs available.

**AHX Hubs** have been developed to accommodate large diameter shafts on process equipment. Large hubs cannot normally be used because of bolt withdrawal fouling the nearest obstruction. The AHX bolts withdraw from the spacer end thus eliminating this problem, allowing the hub to be mounted close to the equipment casing. Coupling sizes can be kept to a minimum.

- **Torsiflex** Couplings consist of 2 hubs and a factory assembled transmission unit. Installation involves fitting the hubs to the machinery shaft ends, introducing the transmission unit, then securing with the attachment screws.
- **Maximum Speeds** shown are for standard materials. When higher speeds are required, please consult Bibby Turboflex.
- **Peak Torque** of 1.75 and **Momentary Torque** of 2.7 times the stated ratings are accepted.
- **Spark Free** overload protection is provided as a standard feature on all Torsiflex couplings making them suitable for GAS ZONE environments.
- **Suitable** for temperatures of minus 20°C.
- **Standard Spacer Lengths** 100, 125, 140, 180, & 250mm provide the most economical solution and are generally available from stock. Other spacer lengths are available to order.
- **Standard Couplings** are designed for general purpose applications and are suitable for the majority of process pump, fan, and compressor applications. Special versions available include:
  - Torque overload protection
  - Limited end float
  - Electrical insulation
  - Bolted adapters suitable for high cyclic torques & frequent start
  - Large Hubs (AHX style)

# COUPLING STYLE BOLTED ADAPTER

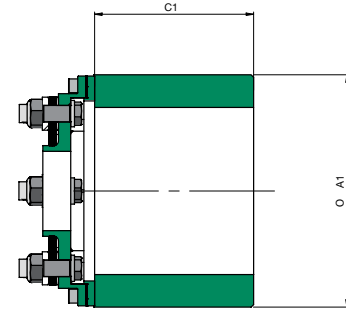
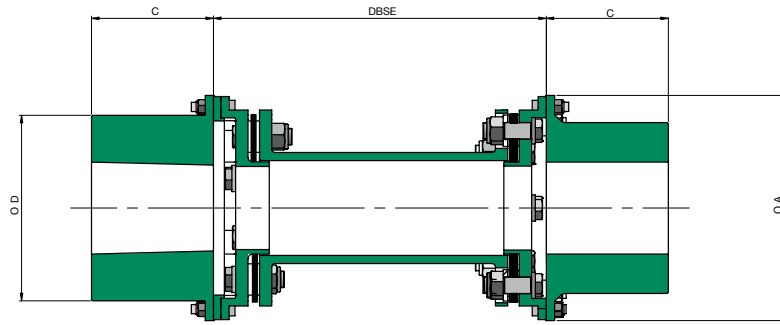

AHX HUB (Size 140-16500)

Coupling Size TF	kW/ RPM	Rating Nm	MAX SPEED RPM	COUPLING DIMENSIONS						MAX BORE	Mass Unbored (Solid) Hub (Kg)	MAX BORE	Mass Unbored (Solid) Hub (Kg)	Mass Transmission Unit (Kg)	
				A	A1	C	C1	D	Min DBSE mm**					Std LAH Hub	Standard AHX Hub
140	0.147	1400	12000	154	154	85	95	117	100	84	7.5	100	13.8	5.1	0.07
260	0.272	2600	10000	176	176	105	115	138	120	99	12.8	120	21.6	8	0.1
400	0.419	4000	8500	203	204	120	135	158	140	113	19.2	140	34	13.2	0.14
750	0.785	7500	7500	241	241	145	160	190	170	136	33.5	165	56	23.4	0.23
1310	1.37	13100	6500	282	282	150	185	230	200	164	50.6	190	89	39	0.27
1900	1.99	19000	5600	318	318	150	210	262	200	187	65.9	220	130	39	0.33
2230	2.34	22300	5600	318	318	160	210	262	220	187	70.1	220	130	45	0.33
2500	2.62	25000	5200	332	348	164	230	276	220	197	79	240	169	51	0.4
3200	3.35	32000	5200	348	348	175	230	292	240	209	95	240	169	63	0.4
3300	3.46	33000	4900	364	381	182	250	302	240	216	106	260	220	68	0.49
4800	5.03	48000	4900	381	381	200	250	310	260	221	123	260	220	79	0.58
6000	6.28	60000	4000	436	457	230	310	358	260	256	188	320	378	106	0.73
7500	7.85	75000	4000	457	457	240	310	370	280	264	210	320	378	123	0.73
8500	8.90	85000	3600	484	503	262	345	400	320	286	264	360	532	163	0.96
11500	12.04	115000	3600	503	503	270	345	415	340	296	295	360	532	190	1.06
12000	12.57	120000	3000	540	556	292	385	444	340	317	366	400	721	216	1.38
16500	17.28	165000	3000	556	556	300	385	456	360	326	395	400	721	250	1.38

New Sizes Highlighted

\* Large Hub Boss Diameter. \*\* The inclusion of additional features such as packing rings, shims and/or electrical insulation will increase the minimum DBSE (Distance Between Shaft Ends).

## Selection Procedure

1. Select an appropriate service factor "SF"
2. Calculate rating = Power (kW) x SF/Speed (rpm)
3. Select a coupling with sufficient rating
4. Check hub bore is capable of accommodating shafts
5. Check Speed is within the maximum for the coupling selected
6. Specify required dynamic balance
7. Specify the distance between shaft ends and check this is not less than the minimum for the selected coupling

Eg. 90kW Direct on line electric motor driving a centrifugal pump at 3,000 rpm.  
Distance between shaft end = 140mm  
Rating =  $90 \times 1.5 = 0.045 \text{ kW/rpm}$   
3000

### Selection TF0140L140 Screwed Adapter

Max hub bore = 73mm Standard Hub  
Max hub bore = 100mm AHX Hub

or

Selection TF0140L140 Bolted Adapter  
Max hub bore = 84mm LAH Hub  
Max hub bore = 100mm AHX Hub

## Service Factors

Driver	Driven	Service Factor (SF)
Turbines, Soft start motors	Steady Torque Eg. Centrifugal pumps	1.2
DOL (Direct On line) Start Motors	Fluctuating Torque Pumps, Rotary compressors ( frequent starts )	1.5 ( 2 )
DOL (Direct On line) Start Motors	Reciprocating Compressors 1 - 3 cylinders	3
DOL (Direct On line) Start Motors	Reciprocating Compressors 4 - 6 cylinders	2
DOL (Direct On line) Start Motors	Reciprocating Compressors over 6 cylinders	1.5
DOL (Direct On line) Start Motors	Centrifugal Fans forced draught	1.5
DOL (Direct On line) Start Motors	Cooling Tower induced draught	2

For all other applications please contact Bibby Turboflex

## TYPE TFCFT COMPOSITE TUBE ("PLUG-IN") COUPLINGS

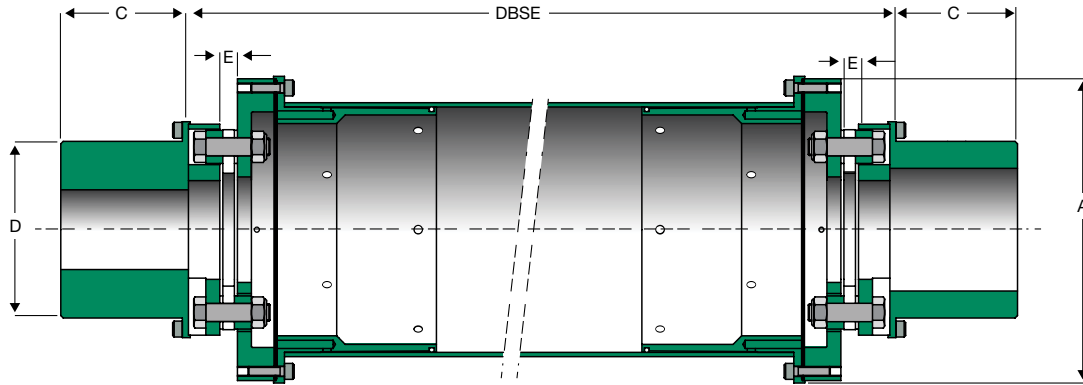

Size	Rating		Max Bore (mm)	Applicable Tube	Dimensions				
	Kw/RPM	Nm			A1	B(Tube OD)	A	C	D
140	0.147	1400	73	T3/T4	147/192	107/157	127	95	101
260	0.272	2600	88	T4/ T5	198/246	157/207	154	115	121
400	0.419	4000	105	T4/T5/T6	198/246/302	157/207/269	176	135	144
750	0.785	7500	120	T5/T6	252/308	207/269	203	160	166
1310	1.37	13100	145	T6	313	269	241	185	199
1900	1.99	19000	170	T6/T7	325/410	269/350	279	210	233
2500	2.62	25000	175	T6/T7	345/430	260/350	296	230	240
3300	3.46	33000	190	T7/T8	430/550	350/471	327	250	270
6000	6.28	60000	230	T8	570	471	395	310	322
8500	8.9	85000	260	T8	570	471	444	345	365
12000	12.57	120000	290	T9	613	517	494	385	410

Single Span Configuration					
Tube Ref.	Max. DBSE (meters) @ rpm.				Min. DBSE (meters)
	3000	1500	1000	750	
T3	2.6	3.7	4.5	5.2	0.8
T4	3.1	4.5	5.5	6.6	0.8
T5	3.6	5.1	6.3	7.3	0.8
T6	4.1	5.7	7.1	8.2	1
T7	4.4	6.6	7.7	8.9	1
T8	4.8	6.8	8.4	9.5	1.5
T9	5	7.1	8.7	9.9	1.5

Special features can be designed into the coupling to suit the application. Taper Lock bushes, thrust buttons for vertical applications, shrink discs, and seal removal pieces are common additions.

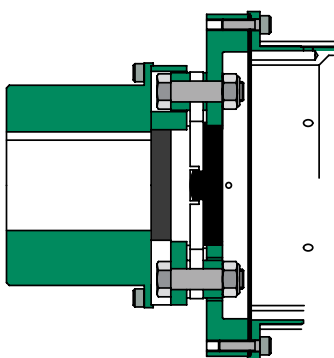

Combined Anti-Flail system and Thrust Button. The Thrust Button is used to support the central spacer in vertical operation.

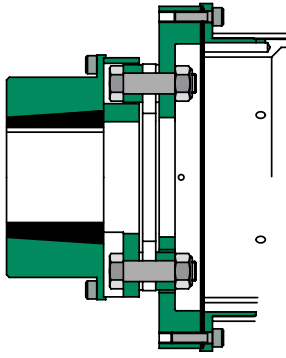

Taper Bush use in the hub at one end of the coupling to permit axial adjustment upon installation. Other clamp systems can also be incorporated into the designs. Please consult Bibby Turboflex.

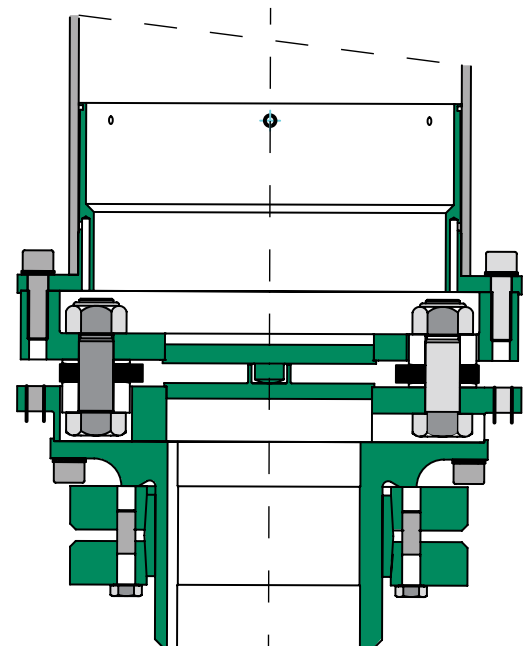

## Type TFCFT Composite Tube (“Plug-in”) Couplings

The TFCFT range of composite tube disc couplings has been designed using the latest material technology- providing lower mass and greater strength. This type of unit was, originally, designed to meet the requirements of cooling towers but has since been adapted to meet the requirements of many alternative applications, specifically long vertical pump and marine drives. In addition to the disc coupling applications, Bibby Turboflex have developed the use of composite tubes in a number of other areas. The tubes have been designed and supplied for use in hovercraft fans, performance car drive shafts and high speed test beds. The tubes are filament wound on accurate mandrels using computer controlled machinery. The resulting tube is cured whilst on the mandrel. This process leads to high accuracy with regard to tube dimensions, roundness and straightness all of which aid in the ability of Bibby Turboflex to supply an extremely high quality product.

Purpose developed software enables Bibby Turboflex to offer tube with fibre windings at angles adjusted to give the optimum performance for specific lateral critical, torque and torsional stiffness requirements.

Bibby Turboflex have the option to wind tubes using a variety of fibres, each of which give specific advantages.

- **Carbon Fibre-** This is the principle material giving a high strength/low mass option for the tubes. This is considered as the standard for the TFCFT range of couplings.
- **Glass Fibre -** Glass fibre offers a low cost solution for many applications of moderate length. The mass to stiffness ratio is less favourable than that for Carbon Fibre but such units do have applications to which they are ideally suited.

- **Carbon/Glass Mix-** The fibre winding approach adopted by Bibby Turboflex enables us to combine these materials to use the advantages of both to give the optimum solution for a specific application.
- **High Modulus Fibre-** Due to its high cost and limited availability, the use of high modulus fibre is generally only adopted for the more extreme applications to give optimum solutions.

The tubes are wrapped in a pigment treated glass fibre layer, which serves to protect them against physical damage and Ultra-Violet degradation.

## Type TFCFT Composite Tube (“Plug-in”) Couplings

### Cooling Tower Fan Drives

Bibby Turboflex composite shaft couplings are perfectly suited for driving cooling tower fans. Their ability to operate over long lengths without central bearings, combined with their inherently low mass and generous misalignment capacity, keeps maintenance of the equipment to a minimum. The maintenance free nature of the Bibby Turboflex disc couplings means the units become virtually “fit & forget”.

The design is such as to make site assembly as easy as possible. The units can be supplied in standard carbon steel with a variety of protective coatings or, if required, in stainless steel.

### Vertical Pump Drives

Bibby Turboflex composite shaft couplings can be employed to great advantage in deep well pump applications such as encountered in water & sewage pumping stations. Their ability to cover long spans without the need for central bearings and their inherent low mass can considerably reduce maintenance costs on units.

This is something advantageous on remote operated or inaccessible plants especially in conjunction with the “fit & forget” nature of the Bibby Turboflex disc couplings.

Material & coatings can be varied to suit the requirements of particular applications.

Axial length adjustment can be incorporated in the couplings in various ways which, when coupled with the generous misalignment capacity and ease of assembly design, can reduce installation time.

When necessary, thrust pins can be added to the unit to support the mass of the central spacer.

### Marine Drives

Bibby Turboflex composite shaft couplings have been successfully utilised in marine applications for both ships & hovercrafts.

The low mass and minimal vibration levels, together with the ability to handle long spans without support bearings, have proved a benefit in many such applications.

### Special Applications

Bibby Turboflex disc couplings with composite spacer shafts are used in many special applications. Their low mass & low inertia, coupled with the ability to adjust the torsional & lateral characteristics of the shaft during manufacture, have made them applicable for many cases where conventional couplings have been inappropriate. Whilst the application for these shafts is as wide as that for couplings themselves, particular success has been found in marine applications, automobile drives and high speed engine test beds.

Whilst the composite shafting is primarily intended for use with Bibby Turboflex disc couplings, it can equally well be incorporated into any other of our wide range of products.

## Misalignment Data

These will be supplied upon request with any order. Guidelines are available for assessment at preliminary stages. The methods of machinery alignment vary accordingly to personal preference. Simple recommended methods are highlighted in our Installation Instructions which are available upon request. The following is a guide to acceptable misalignments at installation.

Note, however, that if machinery growths are known the values may be adjusted in the form of pre-deflection, etc. In addition, please note that the values shown here are **MAXIMUM** values. Reduction in these values will reduce bearing loads and improve the allowance for misalignment due to machinery settlement, etc. thus ensuring greater machinery life and trouble free operation of the coupling.

## Installation Alignment

Recommended Installation Alignments shown as % of the Maximum Permitted values for the Couplings	
Allowable Angular / Radial Misalignment	Allowable Axial Misalignment
20% Maximum	10% Maximum

Note: Angular / Radial as percentage of stated value for 'Point A'. Axial as percentage of stated value for 'Point C'.

## TF Misalignment

Coupling Size TF	Max. Angular Misalignment (Deg)	Bending Moment (Nm)	Max. Axial Deflection (Zero Angular Misalignment) (mm)	Max. Axial Thrust (N)	Max. Axial Deflection at full Angular Misalignment (mm)	Axial Thrust (N)
	Point A (1) (2)	(4)	Point C (3)	Point B (4)		
	Per Element		Per Assembly			
17	0.5	tba	1.2	333	0.25	28
27	.05	tba	1.5	450	0.38	40
38	0.5	tba	2	470	0.5	42
140	0.5	13.5	2.4	1082	0.5	81
260	0.5	20	3	1980	0.7	151
400	0.5	33	3.8	3160	1.2	340
750	0.5	50	4.6	5440	1.5	594
1310	0.5	82	5.5	7800	1.8	867
1900	0.33	131	4.4	9615	1.4	1070
2230	0.33	226	4.8	17300	1.9	2532
2500	0.33	172	4.8	11236	1.5	1214
3200	0.33	237	4.9	15775	1.6	1784
3300	0.33	194	5.3	13695	1.6	1438
4800	0.33	297	5.2	18500	1.5	1820
6000	0.33	390	6.5	20100	2.1	2190
7500	0.33	457	6.5	24000	2	2490
8500	0.33	504	7.2	29400	2.5	3500
11500	0.33	645	6.9	32000	2.1	3264
12000	0.33	595	8.1	32900	2.8	3690
16500	0.33	893	8	41850	2.6	4346

## Definition of Misalignment

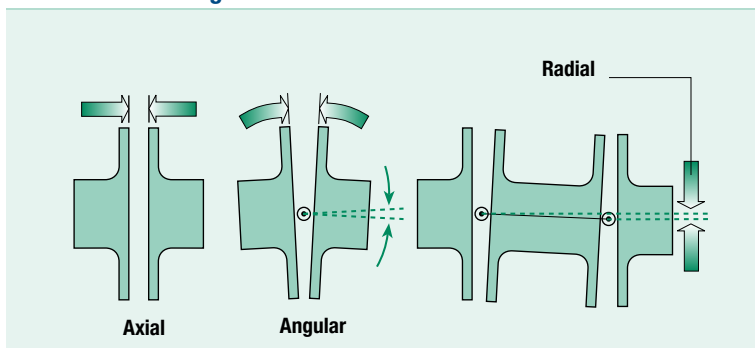

## Type TF - Materials

The following standard materials of construction are used in the Torsiflex range. Alternative materials are available for special applications on request.

- Hubs: Carbon Steel
- Spacers: Carbon Steel
- Adapters: Carbon Steel
- Discs: Stainless Steel (301)
- Bolts: Alloy Steel
- Nuts: Alloy steel
- Overload Collars: High strength 'non-sparking' material

ATEX   
Approval Certificate  
No. SIRA 03XT205

## Allowable Misalignments for Disc Couplings

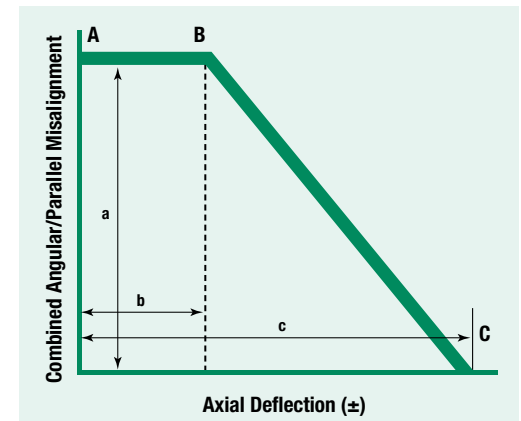

1. Combined angular/radial misalignment
2. 1 degree angle is equivalent to 0.017 mm/mm radial misalignment
3. At zero speed (Static)
4. At maximum speed & continuous rated torque

## Angular & Radial Misalignment in 'Combination'

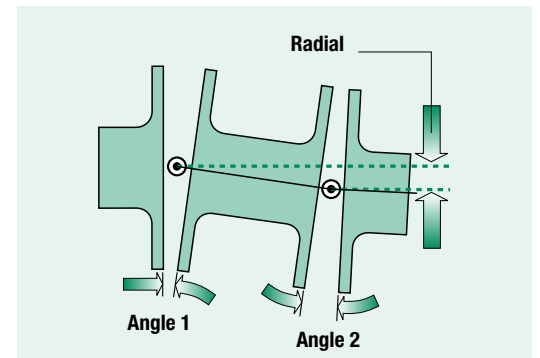



## Torsiflex Couplings

# NOW AVAILABLE WITH **TORSI-LOCK® HUBS**

## Torsi-Lock provides the ease of a slip fit with the power of a shrink fit

Altra Couplings has responded to industry demand for a cold-install hub that provides the secure torque transmission and balance repeatability of an interference fit. We've combined shaft locking devices with Torsiflex to provide a pre-engineered solution that meets the balance requirements of API 610.

- Cold Install means **NO HOT WORK PERMITS**, providing added safety and productivity in hazardous environments
- Easy, repeatable removal and installation
- Eliminates fretting of hub to shaft
- Compensates for variances in shaft spacing – slip on and fix in the needed location
- May be used with keyed or keyless shafts (half key recommended with keyed shafts)
- Fully pre-engineered solution
  - Correct material selection to prevent permanent shrink of hub to shaft
  - Lightest weight locking device/hub combination selected
  - Hub and locking device balanced and match marked to assure optimum balance performance.

For more information visit  
[www.bibbyturboflex.com](http://www.bibbyturboflex.com)

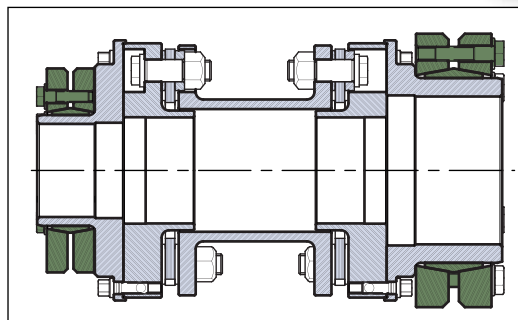

Torsi-Lock can be specified for one or both hubs and sized to accommodate a variety of shaft diameters.

## Bibby Turboflex Facilities

### Europe

Cannon Way, Dewsbury  
West Yorkshire WF13 1EH - England  
+44(0) 1924 460801

*Disc, Gear, Grid Couplings,  
Overload Clutches*

### Africa

Unit 11, Middle Park, Cnr. Craig &  
Dormehl Roads  
Anderbolt, Boksburg, P.O. Box 16524  
Atlasville, 1465 - South Africa  
+27(0) 11 918-4270

*Disc, Gear, Grid Couplings,  
Overload Clutches*

## The Brands of Altra Industrial Motion

### Couplings

**Ameridrives**  
[www.ameridrives.com](http://www.ameridrives.com)

**Bibby Turboflex**  
[www.bibbyturboflex.com](http://www.bibbyturboflex.com)

**Guardian Couplings**  
[www.guardiancouplings.com](http://www.guardiancouplings.com)

**Huco**  
[www.huco.com](http://www.huco.com)

**Lamiflex Couplings**  
[www.lamiflexcouplings.com](http://www.lamiflexcouplings.com)

**Stromag**  
[www.stromag.com](http://www.stromag.com)

**TB Wood's**  
[www.tbwoods.com](http://www.tbwoods.com)

### Gear Cam Limit Switches

**Stromag**  
[www.stromag.com](http://www.stromag.com)

### Electric Clutches & Brakes

**Inertia Dynamics**  
[www.idicb.com](http://www.idicb.com)

**Matrix**  
[www.matrix-international.com](http://www.matrix-international.com)

**Stromag**  
[www.stromag.com](http://www.stromag.com)

**Warner Electric**  
[www.warnerelectric.com](http://www.warnerelectric.com)

### Linear Products

**Warner Linear**  
[www.warnerlinear.com](http://www.warnerlinear.com)

### Engineered Bearing Assemblies

**Kilian**  
[www.kilianbearings.com](http://www.kilianbearings.com)

### Heavy Duty Clutches & Brakes

**Industrial Clutch**  
[www.indclutch.com](http://www.indclutch.com)

**Twiflex**  
[www.twiflex.com](http://www.twiflex.com)

**Stromag**  
[www.stromag.com](http://www.stromag.com)

**Svendborg Brakes**  
[www.svendborg-brakes.com](http://www.svendborg-brakes.com)

**Wichita Clutch**  
[www.wichitaclutch.com](http://www.wichitaclutch.com)

### Belted Drives

**TB Wood's**  
[www.tbwoods.com](http://www.tbwoods.com)

### Gearing

**Bauer Gear Motor**  
[www.bauergears.com](http://www.bauergears.com)

**Boston Gear**  
[www.bostongear.com](http://www.bostongear.com)

**Delroyd Worm Gear**  
[www.delroyd.com](http://www.delroyd.com)

**Nuttall Gear**  
[www.nuttallgear.com](http://www.nuttallgear.com)

### Overrunning Clutches

**Formsprag Clutch**  
[www.formsprag.com](http://www.formsprag.com)

**Marland Clutch**  
[www.marland.com](http://www.marland.com)

**Stieber**  
[www.stieberclutch.com](http://www.stieberclutch.com)

Neither the accuracy nor completeness of the information contained in this publication is guaranteed by the company and may be subject to change in its sole discretion. The operating and performance characteristics of these products may vary depending on the application, installation, operating conditions and environmental factors. The company's terms and conditions of sale can be viewed at <http://www.altramotion.com/terms-and-conditions/sales-terms-and-conditions>. These terms and conditions apply to any person who may buy, acquire or use a product referred to herein, including any person who buys from a licensed distributor of these branded products.

©2018 by Bibby Turboflex LLC. All rights reserved. All trademarks in this publication are the sole and exclusive property of Bibby Turboflex LLC or one of its affiliated companies.



[www.bibbyturboflex.com](http://www.bibbyturboflex.com)



Tfn. 943 457200 | [atencioncliente@sitsa.es](mailto:atencioncliente@sitsa.es) | [www.sitsa.es](http://www.sitsa.es)

P-1943-BB 1/18

06\_04\_01