

Elastomeric Coupling Catalog

Download the most up-to-date
versions at www.rexnord.com



Falk Wrapflex Elastomeric Couplings (Metric)



FALK®

Table Of Contents

DESCRIPTION	PAGE
Falk® Wrapflex® Elastomeric Couplings	3
Falk Wrapflex Coupling Selection	4, 5
Service Factors	6
COUPLING SIZES AND DIMENSIONS	
Close-Coupled Type R10	7
QD Bushings Type R10	8
Taper-Lock® Bushings Type R10	9
Full Spacer Type R31	10
Half Spacer Type R35	11
TECHNICAL DATA	
Bore Specifications and Keyways — All Rexnord Couplings	12, 13
Mill Motor Selection	14
Misalignment Capacity, Mass & WR ²	15

Falk Wrapflex Elastomeric Couplings

A Simple Way to Increase Productivity

- 9 sizes
- Torque range: 15,027 Nm (133,000 lb-in)
- Bore capacity: 190 mm (7.25")
- "Replace in place"
- Non-lubricated/low maintenance

Quick, easy installation and replacement set new standards for reduced downtime. Because motors or drives don't need to be moved, our "replace in place" elements even eliminate the need for time-consuming realignment.

Available in close-coupled and spacer designs, Wrapflex couplings accommodate up to 190 mm (7.25") shafts and torque loads up to 15,027 Nm (133,000 lb-in).

For simplicity and cost-effectiveness over the life of your coupling, it doesn't get any easier than Wrapflex couplings from Rexnord.

Low Initial Cost

- Advanced manufacturing methods and innovative material allow us to offer higher capacity ratings at a more competitive price than ever before possible.

Easy to Install

- The compound root radius in the element teeth (patent #6,342,011) increases flexibility for easier and quicker assembly.
- The coupling can be blind assembled from either direction.



Replace in Place

- Design allows quick and easy element replacement.
- There's no need to remove hubs or realign motors or drives, so downtime is reduced.

No Maintenance Needed

- Non-lubricated design of the tough, flexible polyurethane element lowers periodic maintenance costs.

Protects Equipment

- Compound root radius on inner corners of flex element (patent #6,342,011) acts as a stress relief for longer element life.
- Special hub feature reduces reaction loads transferred to connected equipment (patent #6,648,763).

Tough, Long-Lasting

- Polyurethane element has excellent wear and chemical resistance, and an operating temperature of -40°C (-40°F) to 95°C (200°F).
- Weather-resistant, high-grade nylon cover is standard.
- Optional carbon steel covers with black epoxy coating are suitable for highly-corrosive, severe-duty applications. (Standard for sizes 60-80.)
- Optional stainless steel hubs are available for Type R10 when required in the food industry or corrosive environments. Contact Rexnord for Stainless Steel Cover availability.

Safety First

- Two stainless steel button head cap screws, positioned 180° apart, prevent relative motion between cover and element and provide a positive means of retaining the cover to the element.
- Flexible element is retained after failure, helping minimize the potential for damage or personal injury.

Quick and Easy Retrofits

- Compact design eliminates the need for coupling guard redesign on existing applications.
- Stock finished bores in popular sizes. Taper bores for QD and Taper-Lock bushings are available off-the-shelf from our worldwide distribution network.

Falk Wrapflex Coupling Selection

Wrapflex Quick Selection Method

1. Determine Service Factor — Refer to **Table 1** or **4** for motor or turbine driven applications. See **Table 5** for engine drives.
2. Determine Equivalent Power: Refer to **Table 2** — Under the actual kW required and opposite the service factor, read the equivalent kW.
3. Determine Coupling Size:
 - A. Refer to **Table 3** — Trace horizontally from the required speed to a kW value equal to or larger than the equivalent kW determined in Step 2. Read the coupling size at the top of the column.
 - B. Check shaft diameters against coupling maximum bores shown in **Table 3** and on **page 7** thru **11** for the correct coupling size selected.
 - C. In **Table 3**, check the required speed against the allowable speed shown below the correct coupling size selected.
4. Determine Coupling Dimensional Requirements:
 - A. Determine application/design shaft spacing and check application dimension requirements against selected coupling type dimensions shown on **page 7** thru **11**. Confirm sufficient clearances for coupling.
5. Confirm that application ambient operating temperatures are between -40°C (-40°F) to 95°C (200°F). For applications requiring Service Factor above 1.5 and temperatures above 79°C (175°F), consult Rexnord Engineering for selection assistance or optional high temperature elements.

Service Factors are a guide, based on experience, of the ratio between coupling catalog rating and system characteristics. The system characteristics are best measured with a torque meter.

Table 1 — Service Factors







Torque Demands Driven Machine	Typical applications for electric motor or turbine driven equipment	Typical Service Factor
	Constant torque such as Centrifugal Pumps, Blowers and Compressors.	1.0
	Continuous duty with some torque variations including Plastic Extruders, Forced Draft Fans.	1.5
	Light shock loads from Metal Extruders, Cooling Towers, Cane Knife, Log Haul.	2.0
	Moderate shock loading as expected from a Car Dumper, Stone Crusher, Vibrating Screen.	2.5
	Heavy shock load with some negative torques from Roughing Mills, Reciprocating Pumps, Compressors, Reversing Runout Tables.	3.0
	Applications like Reciprocating Compressors with frequent torque reversals, which do not necessarily cause reverse rotations.	Refer to Factory

Table 2 — Equivalent Power = (Actual kW x Service Factor)

Service Factor ①	Actual kW																									
	0,25	0,37	0,55	0,75	1,1	1,5	2,2	3	4	5,5	7,5	9,2	11	15	18,5	22	30	37	45	55	75	90	110	132	150	185
1.0	0,25	0,37	0,55	0,75	1,1	1,5	2,2	3	4,0	5,5	7,5	9,2	11,0	15,0	18,5	22,0	30,0	37,0	45,0	55,0	75,0	90,0	110	132	150	185
1.25	0,31	0,46	0,69	0,9	1,4	1,9	2,8	3,8	5,0	6,9	9,4	11,5	13,8	18,8	23,1	27,5	37,5	46,3	56,3	68,8	93,8	113	138	165	188	231
1.5	0,38	0,56	0,83	1,1	1,7	2,3	3,3	4,5	6,0	8,3	11,3	13,8	16,5	22,5	27,8	33,0	45,0	55,5	67,5	82,5	113	135	165	198	225	278
1.75	0,44	0,65	0,96	1,3	1,9	2,6	3,9	5,3	7,0	9,6	13,1	16,1	19,3	26,3	32,4	38,5	52,5	64,8	78,8	96,3	131	158	193	231	263	324
2.0	0,50	0,74	1,1	1,5	2,2	3,0	4,4	6,0	8,0	11	15,0	18,4	22,0	30,0	37,0	44	60	74,0	90	110	150	180	220	264	300	370
2.5	0,63	0,93	1,4	1,9	2,8	3,8	5,5	7,5	10	13,8	18,8	23,0	27,5	37,5	46,3	55	75	92,5	113	138	188	225	275	330	375	463
3.0	0,75	1,1	1,7	2,3	3,3	4,5	6,6	9,0	12	16,5	22,5	27,6	33,0	45,0	55,5	66	90	111	135	165	225	270	330	396	450	555
3.5	0,88	1,3	1,9	2,6	3,9	5,3	7,7	10,5	14	19,3	26,3	32,2	38,5	52,5	64,8	77	105	130	158	193	263	315	385	462	525	648

① For service factors not listed, Equivalent kW = Actual kW x Service Factor.

Falk Wrapflex Coupling Selection

Table 3 — Falk Wrapflex Coupling Quick Selection Chart

Size	5R	10R	20R	30R	40R	50R	60R	70R	80R
Max Bore (mm)	38	48	60	65	85	105	135	160	190
Max Speed	4500 RPM	4500 RPM	4500 RPM	4500 RPM	3600 RPM	3000 RPM	2500 RPM	2100 RPM	1800 RPM
Torque (Nm)	62	130	316	520	1 028	2 508	4 011	8 011	15 027
kW/100 RPM	0,651	1,357	3,311	5,444	10,74	26,25	41,98	83,52	157,3
RPM	kW Ratings								
4500	29,3	61,2	149	245	–	–	–	–	–
3600	23,4	49	119,3	196	388	–	–	–	–
3000	19,5	40,8	89,2	163	323	788	–	–	–
2500	16,2	34,0	82,8	136	269	657	1050	–	–
2100	13,6	28,6	69,6	114	226	552	882	1761	–
1800	11,7	24,5	59,7	97,7	194	473	756	1510	2832
1750	11,4	23,8	57,9	95,5	189	459	735	1468	2753
1450	9,47	19,8	48,0	79,1	156	381	609	1216	2282
1170	7,61	15,9	38,8	63,7	126	307	491	981	1841
1000	6,5	13,6	33,1	54,4	107	263	420	839	1574
870	5,7	11,9	28,9	47,4	94,0	228	365	730	1369
720	4,7	9,8	23,9	39,2	77,6	189	303	604	1133
650	4,2	8,9	21,6	35,4	70,0	171	273	545	1023
580	3,8	7,9	19,2	31,5	64,4	152	244	486	913
520	3,4	7,1	17,2	28,3	56	137	219	436	818
420	2,7	5,7	13,9	22,9	45,2	110	177	352	661
350	2,3	4,8	11,6	19,0	37,7	91,7	147	294	551
280	1,8	3,8	9,2	15,2	30,1	73,5	118	235	441
230	1,5	3,1	7,6	12,5	24,8	60,4	96,9	193	362
190	1,2	2,6	6,3	10,4	20,4	49,9	79,8	160	299
155	1,0	2,1	5,1	8,4	16,7	40,7	65,1	130	244
125	0,81	1,7	4,1	6,8	13,4	32,8	52,5	105	197
100	0,65	1,4	3,3	5,4	10,7	26,3	42,0	83,5	157
84	0,55	1,1	2,8	4,6	9,0	22,1	35,3	70,5	132
68	0,44	0,93	2,3	3,7	7,3	17,9	28,6	57,1	107
56	0,36	0,76	1,9	3,1	6,0	14,7	23,5	47,0	88,0
45	0,29	0,61	1,5	2,5	4,9	11,9	18,9	37,7	70,8
37	0,24	0,50	1,2	2,0	4,0	9,7	15,5	31,0	58,2
30	0,195	0,41	0,99	1,6	3,2	7,9	12,6	25,1	47,2
25	0,163	0,34	0,83	1,4	2,7	6,6	10,5	21,0	39,4
20	0,130	0,27	0,66	1,1	2,2	5,3	8,4	16,8	31,5
16,5	0,107	0,22	0,55	0,90	1,8	4,3	6,9	13,9	26,0
13,5	0,088	0,18	0,45	0,74	1,5	3,6	5,7	11,3	21,3
11	0,072	0,15	0,37	0,60	1,2	2,9	4,6	9,2	17,3
9	0,059	0,12	0,30	0,49	0,97	2,4	3,8	7,5	14,2
7,5	0,048	0,102	0,25	0,41	0,81	2,0	3,1	6,3	11,8
5	0,033	0,068	0,17	0,27	0,54	1,3	2,1	4,2	7,9

Service Factors

Table 4 — Flexible Coupling Service Factors for Motor ① and Turbine

Service factors listed are typical values based on normal operation of the drive systems.

Application	Service Factor	Application	Service Factor
AERATOR	2.0	HAMMERMILL	1.75
AGITATORS		LAUNDRY WASHER OR TUMBLER	2.0
Vertical and Horizontal		LINE SHAFTS	
Screw, Propeller, Paddle	1.0	Any Processing Machinery	1.5
BARGE HAUL PULLER	1.5	MACHINE TOOLS	
BLOWERS		Auxiliary and Traverse Drive	1.0
Centrifugal	1.0	Bending Roll, Notching Press, Punch Press,	
Lobe or Vane	1.25	Planer, Plate Reversing	1.75
CAR DUMPERS	2.5	Main Drive	1.5
CAR PULLERS	1.5	MAN LIFTS	Not Approved
CLARIFIER OR CLASSIFIER	1.0	METAL FORMING MACHINES	
COMPRESSORS		Continuous Caster	1.75
Centrifugal	1.0	Draw Bench Carriage and Main Drive	2.0
Rotary, Lobe or Vane	1.25	Extruder	2.0
Rotary, Screw	1.0	Farming Machine and Forming Mills	2.0
Reciprocating		Slitters	1.0
Direct Connected	Refer to Factory	Wire Drawing or Flattening	1.75
Without Flywheel	Refer to Factory	Wire Winder	1.5
② With Flywheel and Gear between Compressor and Prime Mover		Coilers and Uncoilers	1.5
1 cylinder, single acting	3.0	MIXERS (see Agitators)	
1 cylinder, double acting	3.0	Concrete	1.75
2 cylinders, single acting	3.0	Muller	1.5
2 cylinders, double acting	3.0	PRESS, PRINTING	1.5
3 cylinders, single acting	3.0	PUG MILL	1.75
3 cylinders, double acting	2.0	PULVERIZERS	
4 or more cyl., single act.	1.75	Hammermill and Hog	1.75
4 or more cyl., double act.	1.75	Roller	1.5
③ CONVEYORS		PUMPS	
Apron, Assembly, Belt, Chain, Flight, Screw	1.0	Boiler Feed	1.5
Bucket	1.25	Centrifugal — Constant Speed	1.0
Live Roll, Shaker and Reciprocating	3.0	Frequent Speed Changes under Load	1.25
④ CRANES AND HOIST		Descaling, with accumulators	1.25
Main Hoist	1.75 ③	Gear, Rotary, or Vane	1.25
Skip Hoist	1.75 ③	Reciprocating, Plunger Piston	
Slope	1.5	1 cyl., single or double act.	3.0
Bridge, Travel or Trolley	1.75	2 cyl., single acting	2.0
DYNAMOMETER	1.0	2 cyl., double acting	1.75
ELEVATORS		3 or more cylinders	1.5
Bucket, Centrifugal Discharge	1.25	Screw Pump, Progressing Cavity	1.25
Freight or Passenger	Not Approved	Vacuum Pump	1.25
Gravity Discharge	1.25	SCREENS	
ESCALATORS	Not Approved	Air Washing	1.0
EXCITER, GENERATOR	1.0	Grizzly	2.0
EXTRUDER, PLASTIC	1.5	Rotary Coal or Sand	1.5
FANS		Vibrating	2.5
Centrifugal	1.0	Water	1.0
Cooling Tower	2.0	SKI TOWS & LIFTS	Not Approved
Forced Draft — Across the Line start	1.5	STEERING GEAR	1.0
Forced Draft Motor driven thru fluid or electric slip clutch	1.0	STOKER	1.0
Gas Recirculating	1.5	TIRE SHREDDER	1.50
Induced Draft with damper control or blade cleaner	1.25	TUMBLING BARREL	1.75
Induced Draft without controls	2.0	WINCH, MANEUVERING	
FEEDERS		Dredge, Marine	1.5
Apron, Belt, Disc, Screw	1.0	WINDLASS	1.5
Reciprocating	2.5	WOODWORKING MACHINERY	1.0
GENERATORS		WORK LIFT PLATFORMS	Not Approved
Even Load	1.0		
Hoist or Railway Service	1.5		
Welder Load	2.0		

- ① For engine drives, refer to **Table 5**. Electric motors, generators, engines, compressors and other machines fitted with sleeves or straight roller bearings usually require limited end float couplings. If in doubt, provide axial clearances and centering forces to the Factory for a recommendation.
- ② For balanced opposed design, refer to the Factory.
- ③ If people are occasionally transported, refer to the Factory for the selection of the proper size coupling.
- ④ For high peak load applications (such as Metal Rolling Mills) refer to the Factory.

Table 5 — Engine Drive Service Factors ⑤

Service Factors (S.F.) for engine drives are those required for applications where good flywheel regulation prevents torque fluctuations greater than ±20%. For drives where torque fluctuations are greater or where the operation is near a serious critical or torsional vibration, a mass elastic study is necessary.

No. of Cylinders	4 or 5 ⑤					6 or more ⑤				
	1.0	1.25	1.5	1.75	2.0	1.0	1.25	1.5	1.75	2.0
Table 4 S.F.	1.0	1.25	1.5	1.75	2.0	1.0	1.25	1.5	1.75	2.0
Engine S.F.	2.0	2.25	2.5	2.75	3.0	1.5	1.75	2.0	2.25	2.5

- ⑤ To use **Table 5**, first determine application service factor from **Table 4**. Use that factor to determine Engine S.F. from **Table 5**. When service factor from **Table 4** is greater than 2.0, or where 1, 2, or 3 cylinder engines are involved, refer complete application details to Rexnord Engineering.

Drives

Industry	Service Factor	Industry	Service Factor
AGGREGATE PROCESSING, CEMENT, MINING		Shear, Croppers	Refer to Factory
KILNS; TUBE, ROD AND BALL MILLS		Sideguards	3.0
Direct or on L.S. shaft of Reducer,		Sklep Mills	Refer to Factory
with final drive Mached Spur Gears	2.0	Slitters, Steel Mill only	1.75
Single Helical or Herringbone Gears	1.75	Soaking Pit Cover Drives —	
Conveyors, Feeders, Screens,		Lift	1.0
Elevators	See General Listing	Travel	2.0
Crushers, Ore or Stone	2.5	Straighteners	2.0
Dryer, Rotary	1.75	Unscramblers (Billet Bundle Busters)	2.0
Grizzly	2.0	Wire Drawing Machinery	1.75
Hammermill or Hog	1.75	OIL INDUSTRY	
Tumbling Mill or Barrel	1.75	Chiller	1.25
BREWING AND DISTILLING		Oilwell Pumping (not over 150% peak torque)	2.0
Bottle and Can Filling Machines	1.0	Paraffin Filter Press	1.5
Brew Kettle	1.0	Rotary Kiln	2.0
Cookers, Continuous Duty	1.25	PAPER MILLS	
Lauter Tub	1.5	Barker Auxiliary, Hydraulic	2.0
Mash Tub	1.25	Barker, Mechanical	2.0
Scale Hopper, Frequent Peaks	1.75	Barking Drum	
CLAY WORKING INDUSTRY		L.S. shaft of reducer with final drive - Helical	
Brick Press, Briquette Machine, Clay Working Machine, Pug Mill	1.75	or Herringbone Gear	2.0
DREDGES		Machined Spur Gear	2.5
Cable Reel	1.75	Cast Tooth Spur Gear	3.0
Conveyors	1.25	Beater & Pulper	1.75
Cutter head, Jig Drive	2.0	Bleachers, Coaters	1.0
Maneuvering Winch	1.5	Calender & Super Calender	1.75
Pumps (uniform load)	1.5	Chipper	2.5
Screen Drive, Stacker	1.75	Converting Machine	1.25
Utility Winch	1.5	Couch	1.75
FOOD INDUSTRY		Cutter, Felt Whipper	2.0
Beer Slicer	1.75	Cylinder	1.75
Bottling, Can Filling Machine	1.0	Dryer	1.75
Cereal Cooker	1.75	Felt Stretcher	1.25
Dough Mixer, Meat Grinder	1.75	Fourdrinier	1.75
LUMBER		Jordan	2.0
Band Resaw	1.5	Log Haul	2.0
Circular Resaw, Cut-off	1.75	Line Shaft	1.5
Edger, Head Rig, Hog	2.0	Press	1.75
Gang Saw (Reciprocating)	Refer to Factory	Pulp Grinder	1.75
Log Haul	2.0	Reel, Rewinder, Winder	1.5
Planer	1.75	Stock Chest, Washer, Thickener	1.5
Rolls, Non-Reversing	1.25	Stock Pumps, Centrifugal	
Rolls, Reversing	2.0	Constant Speed	1.0
Sawdust Conveyor	1.25	Frequent Speed Changes Under Load	1.25
Slab Conveyor	1.75	Suction Roll	1.75
Sorting Table	1.5	Vacuum Pumps	1.25
Trimmer	1.75	RUBBER INDUSTRY	
⑤ METAL ROLLING MILLS		Calender	2.0
Coilers (Up or Down) Cold Mills only	1.5	Cracker, Plasticator	2.5
Coilers (Up or Down) Hot Mills only	2.0	Fxmrlr	1.75
Coke Plants		Intensive or Banbury Mixer	2.5
Pusher Ram Drive	2.5	Mixing Mill, Refiner or Sizer	
Door Opener	2.0	One or two in line	2.5
Pusher or Larry Car Traction Drive	3.0	Three or four in line	2.0
Continuous Caster	1.75	Five or more in line	1.75
Cold Mills — Strip Mills	Refer to Factory	Tire Building Machine	2.5
Temper Mills	Refer to Factory	Tire & Tube Press Opener (Peak Torque)	1.0
Cooling Beds	1.5	Tuber, Strainer, Pelletizer	1.75
Drawbench	2.0	Warming Mill	
Feed Rolls - Blooming Mills	3.0	One or two Mills in line	2.0
Furnace Pushers	2.0	Three or more Mills in line	1.75
Hot and Cold Saws	2.0	Washer	2.5
Hot Mills —		SEWAGE DISPOSAL EQUIPMENT	
Strip or Sheet Mills	Refer to Factory	Bar Screen, Chemical Feeders, Collectors,	
Reversing Blooming	Refer to Factory	Dewatering Screen, Grit Collector	1.0
Slabbing Mills	Refer to Factory	SUGAR INDUSTRY	
Edger Drives	Refer to Factory	Cane Carrier & Leveler	1.75
Ingot Cars	2.0	Cane Knife & Cusher	2.0
Manipulators	3.0	Mill Stands, Turbine Drive with all Helical or Herringbone gears	1.5
Merchant Mills	Refer to Factory	Electric Drive or Steam Engine Drive with Helical, Herringbone, or Spur Gears	
Mill Tables		with any Prime Mover	1.75
Roughing Breakdown Mills	3.0	TEXTILE INDUSTRY	
Hot Bed or Transfer, non-reversing	1.5	Batcher	1.25
Runout, reversing	3.0	Calender, Card Machine	1.5
Runout, non-reversing, non-plugging	2.0	Cloth Finishing Machine	1.5
Reel Drives	1.75	Dry Can, Loom	1.5
Rod Mills	Refer to Factory	Dyeing Machinery	1.25
Screwdown	2.0	Knitting Machine	Refer to Factory
Seamless Tube Mills		Mangle, Napper, Soaper	1.25
Piercer	3.0	Spinner, Tenter Frame, Winder	1.5
Thrust Block	2.0		
Tube Conveyor Rolls	2.0		
Reeler	2.0		
Kick Out	2.0		

Close-Coupled Type R10

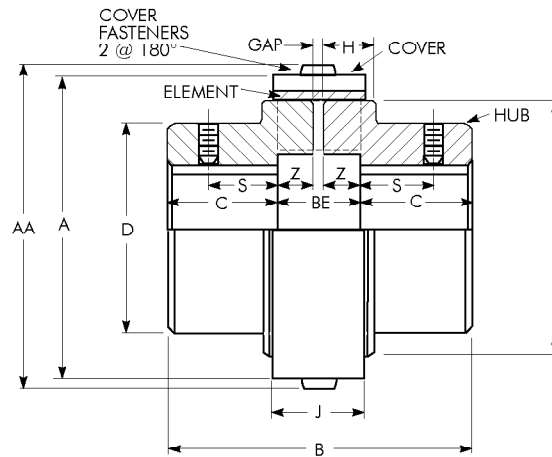

Dimensions (mm)

Cplg Size ①	Torque Rating (Nm)	Allow Speed RPM	Min Bore	Max Bore ②	Cplg Wt (kg) ③		A		AA		B	BE ⑤	C	D	F	H	J	S	Z	GAP ⑥	Cover Fasteners ⑦	
					Nylon Cover	Steel Cover ④	Nylon Cover	Steel Cover ④	Nylon Cover	Steel Cover ④											Size	Allen Wrench
5R	62	4500	12,7	38,00	1,35	1,49	76,5	76,5	80,5	80,4	71,9	19,8	25,9	59,9	64,0	15,0	23,1	16	8,9	2,00	M4	M2,5
10R	130	4500	15,88	48,00	2,49	2,72	90,4	90,4	94,5	94,4	91,9	23,9	34,0	72,1	75,9	19,1	27,9	22,4	10,9	2,00	M4	M2,5
20R	316	4500	19,05	60,00	5,64	6,09	126	124	132	130	121,9	32,0	45,0	91,9	102,1	24,9	37,1	25,4	15,0	2,00	M6	M4
30R	520	4500	25,4	65,00	9,41	10	146,6	143	153	149	151,9	36,1	57,9	104,9	118,1	29	41,9	31,8	17,0	2,00	M6	M4
40R	1028	3600	28,58	85,00	17,1	18,1	182,1	177	190	185	181,1	47,0	67,1	130	150,1	34	54,6	41,4	21,1	5,00	M8	M5
50R	2508	3000	31,75	105,00	35,8	37,7	230,9	224	239	232	214,9	60,7	77,0	178,1	190	46	69,6	44,5	27,9	5,00	M8	M5
60R	4011	2500	50,8	135,00	–	66,4	–	267	–	278	275,3	75,4	100,1	209,6	228,1	60,2	67,1	–	35,3	5,00	M10	M6
70R	8011	2100	69,85	160,00	–	111	–	310	–	321	324,1	84,1	119,9	251	270	69,6	74,9	–	39,6	5,00	M10	M6
80R	15027	1800	85,73	190,00	–	166	–	370	–	381	376,9	97,0	140	270	327,9	83,3	85,1	–	45,5	6,00	M10	M6

- ① Wrapflex is a metric product. Metric to inch conversions may not be direct. Dimensions are for reference only and are subject to change without notice unless certified.
- ② AGMA Class 1 clearance fit bores are standard for Sizes 5R thru 50R, with two setscrews (one over keyway and one at 90°). Interference fit bores and one setscrew over keyway is standard for 60 thru 80R. Long hubs and interference fits are available and recommended when at or near maximum bore and: a) Number of start/stop cycles exceeds 10 per hour; or b) Application service factor = 2.0 or higher.
- ③ Coupling assembly weight is based on "no bore" hubs. For coupling assembly weight and bored hubs, subtract the following value for each hub: $(5,08)(\text{Bore})^2(C)$ kg Bore in "millimeters".
- ④ Nylon cover is standard on Sizes 5R thru 50R, with an epoxy-coated steel cover as an option. Epoxy-coated steel cover is standard on Sizes 60R thru 80R, with no option for nylon cover.
- ⑤ "BE" = Standard "Distance Between Shaft Ends" with hubs mounted flush to the shaft ends. "GAP" = Minimum allowable "Distance Between Shaft Ends". Any shaft end spacing between the "GAP" and "BE" dimensions is acceptable. However, if utilizing a shaft end spacing less than the "BE" dimension, the key should not extend beyond the hub face in order to prevent potential interference with the flex element.
- ⑥ Cover fasteners are stainless steel, socket button head cap screws, per ISU 7380-A2. Two cap screws per coupling assembly.

NOTE: Dimensions subject to change. Certified dimensions of ordered material furnished on request.

(491-110M) 7

QD Bushings Type R10

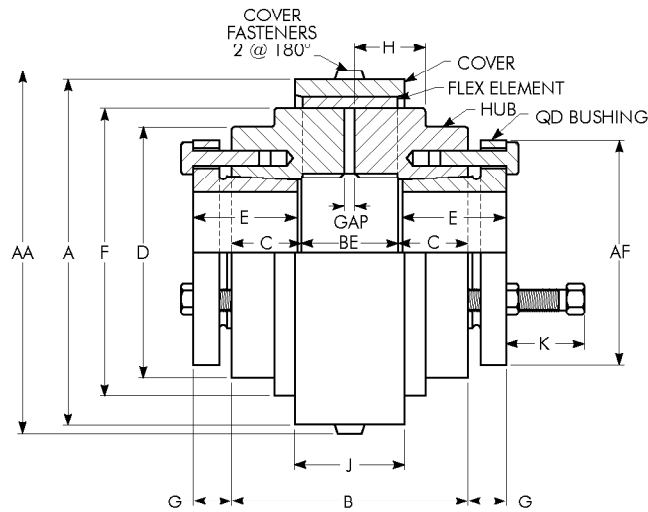

Dimensions (mm)

Coupling Size	Bushing Size	Torque Rating ① (Nm)	Kw per 100 RPM	Max RPM	Max Bore ①	Min Bore ①	Coupling Weight without Bushing		GAP	BE
							Nylon Cover (kg)	Steel Cover (kg)		
5R	JA	62	0,65	4500	30	15	0,968	1,1	2	20
10R	JA	113	1,18	4500	30	15	1,59	1,81	2	24
20R	SD	316	3,31	4500	43	24	3,06	3,54	2	32
30R	SD	520	5,44	4500	43	24	4,64	5,27	2	36
40R	SF	1028	10,8	3600	63	28	7,73	8,73	5	47
50R	E	2260	23,7	3000	89	35	17,5	19,4	5	61
60R	J	4011	42	2500	114	50	NA	39,2	5	75,4
70R	J	5085	53	2100	114	50	NA	64,5	5	84,4
80R	M ②	9600	101	1800	139	80	NA	115,5	6	96,8

Coupling Size	Cover Fasteners ③		Bushing Fasteners ③ Inch Hardware	AA – Nylon Cover	AA – Steel Cover	A – Nylon Cover	A – Steel Cover	AF ①	B
	Size	Hex Tool							
5R	M4	M2,5	#10-24 x 1.00	80,5	80,4	76,5	76,5	50,8	71,9
10R	M4	M2,5	#10-24 x 1.00	94,5	94,4	90,4	90,4	50,8	75,9
20R	M6	M4	1/4-20 x 1.00	132	130	126	124	81	96
30R	M6	M4	1/4-20 x 1.00	153	149	146,6	143	81	100,1
40R	M8	M5	3/8-16 x 1.25	190	185	182,1	177	117,6	114,8
50R	M8	M5	1/2-13 x 1.75	239	232	230,9	224	152,4	144,8
60R	M10	M6	5/8-11 x 2.50	–	278	–	267	184,2	237,2
70R	M10	M6	5/8-11 x 2.50	–	321	–	309,9	184,2	246,1
80R	M10	M6	3/4-10 x 3.00	–	381	–	370,1	231,9	361,2

Coupling Size	C	D	E □	F	G ①	H	J – Nylon Cover	J – Steel Cover	K – Clearance
5R	26	59,9	25,4	64	11,2	15	23,1	23,1	29,5
10R	26	72,1	25,4	76	11,2	19,1	27,9	27,9	29,5
20R	32	91,9	46	102	14,2	24,9	37,1	37,1	30,2
30R	32	104,9	46	118	14,2	29	41,9	41,7	30,2
40R	34	130	50,8	150	21,3	34	54,6	53,1	38,1
50R	42	178,1	66,8	190	28,7	46	69,6	67,3	54,1
60R	81	209,6	114,3	228	38,1	60,2	–	67,1	74,7
70R	81	251	114,3	270	38,1	69,6	–	74,9	74,7
80R	132	270	171,5	328	42,2	83,3	–	85,1	88,9

① May vary depending upon bushing manufacturer. Consult bushing manufacturer for specific dimension if required..

② 80R requires a special "M" bushing, manufactured for "reverse" mounting. Consult bushing manufacturer.

③ Cover fasteners are ISO 7380, stainless steel, socket button head cap screws. Bushing fasteners are SAE Grade 5 (inch) or ISO 8.8 (metric), hex head cap screws.

Taper-Lock BSW® Bushings Type R10

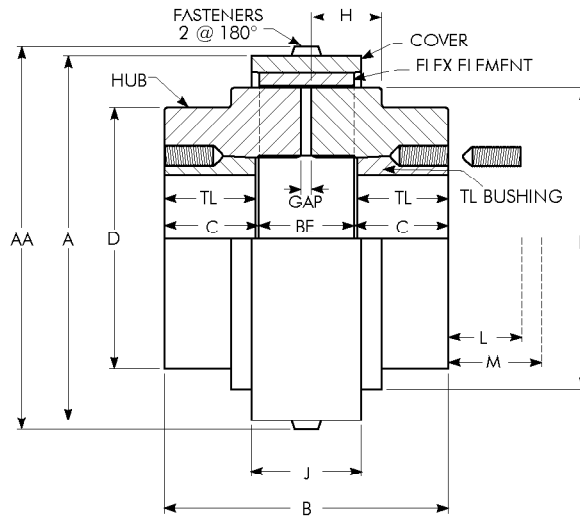

Dimensions (mm)

Coupling Size	Bushing Size	Torque Rating ① (Nm)	Kw per 100 RPM	Max RPM	Max Bore ①	Min Bore ①	Coupling Weight w/o Bushing		GAP
							Nylon Cover (kg)	Steel Cover (kg)	
5R	1108	62	0,65	4500	28	13	0,807	0,943	2
10R	1210	130	1,36	4500	32	13	1,56	1,78	2
20R	1610	316	3,31	4500	42	13	3,11	3,59	2
30R	2012	520	5,44	4500	50	13	4,85	5,49	2
40R	2517	1028	10,8	3600	65	13	8,80	9,84	5
50R	3020	2508	26,3	3000	80	24	18,6	20,4	5
60R	4040	4011	42	2500	105	37	–	35,3	5
70R	4545	8011	84	2100	115	50	–	54,4	5
80R	5050	14236	149	1800	127	61	–	103	6

Coupling Size	BE	Cover Fasteners ②		A – Nylon Cover	A – Steel Cover	AA – Nylon Cover	AA – Steel Cover	B	C
		Size	Hex Tool						
5R	20,0	M4	M2,5	76,5	76,5	80,5	80,4	65,0	22,5
10R	24,0	M4	M2,5	90,4	90,4	94,5	94,4	90,0	33,0
20R	32,0	M6	M4	126	124	132	130	98,0	33,0
30R	36,0	M6	M4	146,6	143	153	149	120,0	42,0
40R	47,0	M8	M5	182,1	177	190	185	139,0	46,0
50R	61,0	M8	M5	230,9	224	239	232	171,0	55,0
60R	75,4	M10	M6	–	267	–	278	245,4	85,0
70R	84,4	M10	M6	–	309,9	–	321	264,4	90,0
80R	96,8	M10	M6	–	370,1	–	381	304,8	104,0

Coupling Size	D	F	H	J – Nylon Cover	J – Steel Cover	L ③		M ④		TL
						Standard Hex Key	Short ⑤	Standard Hex Key	Short ⑤	
5R	59,9	64,0	15,0	23,1	23,0	29	16	32	19	22
10R	72,1	75,9	19,1	27,9	28,0	35	21	42	27	25
20R	91,9	102,1	24,9	37,1	37,1	35	21	42	27	25
30R	104,9	118,1	29	41,9	41,6	40	24	51	35	32
40R	130	150,1	34	54,6	53,0	42	26	58	42	45
50R	178,1	190	46	69,6	67,2	46	31	69	53	51
60R	209,6	228,1	60,2	–	67,1	61	42	105	86	76
70R	251	270	69,6	–	74,9	67	50	121	104	89
80R	270	327,9	83,3	–	85,1	72	59	134	123	102

① Typical – refer to bushing manufacturer for exceptions and service factor limitations.

② Cover fasteners are ISO 7380, stainless steel, socket button head cap screws.

③ Space required to tighten bushing. Also, space required to loosen screws to permit removal of hub by puller.

④ Space required to remove bushing using jack screws – no puller required.

⑤ Standard hex key cut to minimum useable length.

⑥ BSW (British Standard Whitworth) threads (55° Pressure Angle) are common outside USA (UNC thread with 60° Pressure Angle). BSW are considered by same manufacturers to be interchangeable with UNC threads except for 1/2" x 12 TPI (Threads Per Inch) on 2517 BSW bushing.

NOTE: Dimensions subject to change. Certified dimensions of ordered material furnished on request.

(491-110M) 9

Full Spacer Type R31

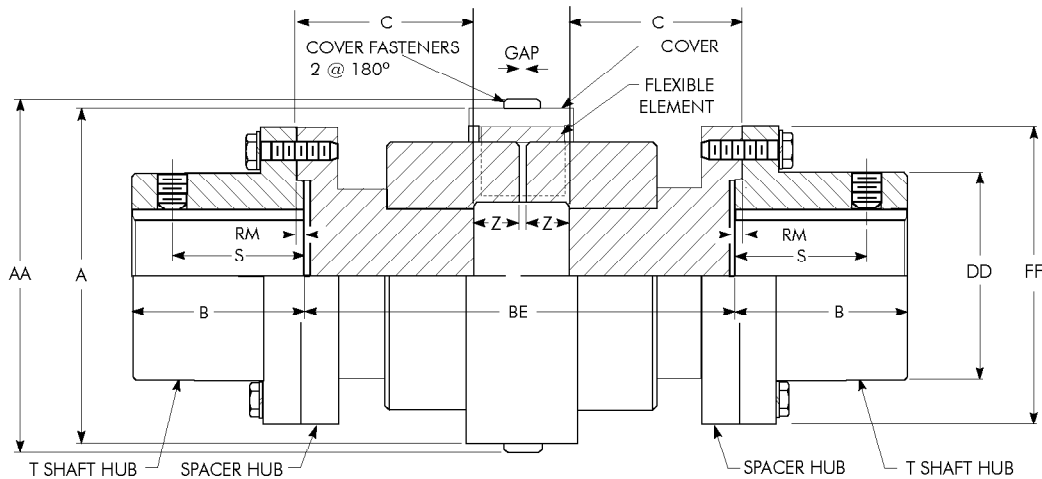

Dimensions (mm)

NOTE: Distance Between Shaft Ends (BE) = 2(C) + 2(Z) + GAP - 2(RM)

Cplg Size ①	Spacer Dimensions																			T Shaft Hub			
	Torque Rating (Nm)	Allow Speed RPM	Max Bore ⑤	Cplg Wt No Bore - kg		BE		A				AA				Cover Fasteners ③		Flange Fasteners ④					
				At Min BE (kg)	Per Added BE (kg/mm)	Min	Max	Nylon Cover	Steel Cover ②	Nylon Cover	Steel Cover ②	B	DD	FF	RM	S	Z	GAP	Size		Allen Wrench Tool	Size	No. Per Flange
5R	62	4500	35	3,63	0,014	80,9	235	76,5	76,5	80,5	80,4	34,9	52,4	86	1,27	27,4	8,9	2	M4	M2,5	M6	4	1020T
10R	130	4500	43	4,99	0,015	88,9	254	90,4	90,4	94,5	94,4	41,3	59,5	94	1,27	31,5	10,9	2	M4	M2,5	M6	8	1030T
20R	316	4500	56	9,53	0,027	88,9	254	126	124	132	130	54,0	78,6	113	1,27	27,4	15,0	2	M6	M4	M6	8	1040T
30R	520	4500	67	14,1	0,034	111	254	146,6	143	153	149	60,3	87,3	126	1,27	40,6	17,0	2	M6	M4	M8	8	1050T
40R	1028	3600	85	25,9	0,040	127	311	182,1	177	190	185	79,4	109,5	153	1,27	46,7	21,1	5	M8	M5	M10	12	1070T
50R	2508	3000	95	45,4	0,059	165	311	230,9	224	239	232	88,9	122,2	178	1,27	49,8	27,9	5	M8	M5	M12	12	1080T
60R	4011	2500	110	72,6	0,082	200	311	-	267	-	278	101,6	142,9	210	1,27	-	35,3	5	M10	M6	M16	12	1090T
70R	8011	2100	130	102	0,117	224	373	-	310	-	321	90,4	171,4	251	1,52	-	39,6	5	M10	M6	M20	12	1100T
70R	8011	2100	150	120	0,117	224	373	-	310	-	321	104,1	196,8	276	1,52	-	39,6	5	M10	M6	M20	12	1110T
80R	15027	1800	170	188	0,144	250	424	-	370	-	381	119,4	225,4	320	2,39	-	45,5	6	M10	M6	M24	12	1120T
80R	15027	1800	190	230	0,240	256	424	-	370	-	381	134,6	238,1	347	2,39	-	45,5	6	M10	M6	M27	12	1130T

- ① Wrapflex is a metric product. Metric to inch conversions may not be direct. Dimensions are for reference only and are subject to change without notice unless certified.
- ② 5R-50R nylon cover is standard and epoxy coated steel cover is optional. 60R-80R epoxy coated steel cover is standard (nylon cover not available).
- ③ Cover fasteners are ISO 7380, stainless steel, socket button head cap screws. Two cover fasteners per coupling.
- ④ Flange fasteners are ISO Class 10.9 hex head cap screws for 5R thru 80R.
- ⑤ Maximum Inch Bore listed is for a standard square key. Larger bores, with a rectangular key, are available. Sizes 5R-50R are standard clearance fit with setscrew over keyway. Size 60R is standard interference fit with keyway, but no setscrew. For interference fit with setscrew over keyway, refer to 427-105.

Taper-Lock Bushings for T Shaft Hubs

Cplg Size	T Shaft Hub	Assembly Torque Rating (Nm)	kW per 100 RPM	Allow Speed	Bore Range	Bushing Size
5R	1020T	62	0,65	4500	13-28	1108
10R	1030T	130	1,36	4500	13-28	1108
20R	1040T	315	3,31	4500	13-35	1310
30R	1050T	485	5,1	4500	13-42	1615
40R	1070T	994	10,4	3600	20-65	2525
50R	1080T	1276	13,4	3000	20-65	2525
60R	1090T	2710	28,4	2500	24-75	3030
70R	1100T	5062	53,1	2100	31-95	3535
70R	1110T	8000	83,9	2100	37-105	4040
80R	1120T	12428	130	1800	50-115	4545
80R	1130T	14226	149	1800	61-127	5050

Type R31 Standard Spacer Lengths

Cplg Size	BE Lengths (Distance Between Shaft Ends)								
	3.50 in	100 mm	4.38 in	140 mm	5.00 in	180 mm	7.25 in	9.75 in	10.00 in
5R	X	X	X	-	X	-	-	-	-
10R	X	X	X	X	X	-	X	-	-
20R	X	X	X	X	X	-	X	-	-
30R	-	-	X	X	X	X	X	-	-
40R	-	-	-	X	X	X	X	X	-
50R	-	-	-	-	-	-	X	X	X
60R	-	-	-	-	-	-	-	X	-

NOTE: Other BE lengths available. Refer to the Factory.

Half Spacer Type R35

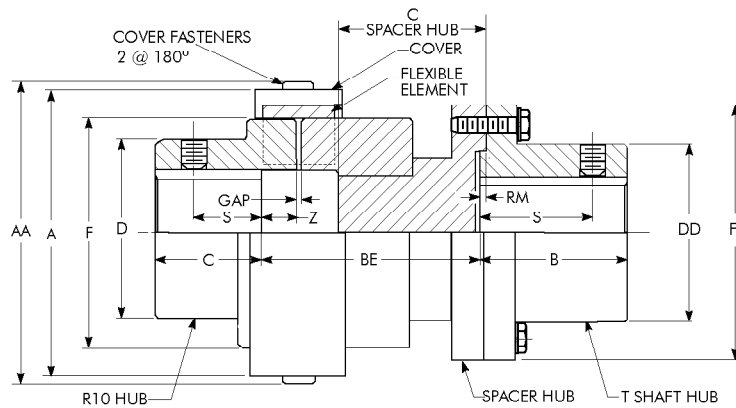

Dimensions (mm)

NOTE: Distance Between Shaft Ends (BE) = (C)Spacer Hub + 2(Z) + GAP – RM

Cplg Size ①	Spacer Dimensions																											
	Torque Rating (Nm)	Allow Speed RPM	Max Bore ③		Cplg Wt No Bore (kg)		BE		A		AA		B	C R10 Hub	D	DD	F	FF	RM	S		Z	GAP	Cover Fasteners ⑤		Flange Fasteners ⑥		T Shaft Hub
			T Shaft Hub	R10 Hub	At Min BE (kg)	Per Added BE (kg/mm)	Min	Max	Nylon Cover	Steel Cover ②	Nylon Cover	Steel Cover ②								Shaft Hub ④	R10 Hub ④			Size	Allen Wrench Tool	Size	No. Per Flange	
5R	62	4500	35	38,00	2,54	0,014	50,5	127,0	76,5	76,5	80,5	80,4	34,9	25,9	59,9	52,4	64,0	86	1,27	27,4	15,9	8,9	2	M4	M2,5	M6	4	1020T
10R	130	4500	43	48,00	3,96	0,015	59,6	140,0	90,4	90,4	94,5	94,4	41,3	34,0	72,1	59,5	75,9	94	1,27	31,5	22,2	10,9	2	M4	M2,5	M6	8	1030T
20R	316	4500	56	60,00	8,44	0,027	76,5	140,0	126	124	132	130	54,0	45,0	91,9	78,6	102,1	113	1,27	27,4	25,4	15,0	2	M6	M4	M6	8	1040T
30R	520	4500	67	65,00	12,9	0,034	87,6	146,1	146,6	143	153	149	60,3	57,9	104,9	87,3	118,1	126	1,27	40,6	31,8	17,0	2	M6	M4	M8	8	1050T
40R	1028	3600	85	85,00	22,4	0,040	88,6	184,2	182,1	177	190	185	79,4	67,1	130	109,5	150,1	153	1,27	46,7	41,3	21,1	5	M8	M5	M10	12	1070T
50R	2508	3000	95	105,00	40,8	0,059	113,1	184,2	230,9	224	239	232	88,9	77,0	178,1	122,2	190	178	1,27	49,8	44,5	27,9	5	M8	M5	M12	12	1080T
60R	4011	2500	110	135,00	69,0	0,082	137,6	203,2	–	267	–	278	101,6	100,1	209,6	142,9	228,1	210	1,27	–	–	35,3	5	M10	M6	M16	12	1090T
70R	8011	2100	130	160,00	106	0,117	153,9	228,9	–	310	–	321	90,4	119,9	251	171,4	270	251	1,52	–	–	39,6	5	M10	M6	M20	12	1100T
70R	8011	2100	150	160,00	115	0,117	153,9	228,9	–	310	–	321	104,1	119,9	251	196,8	270	276	1,52	–	–	39,6	5	M10	M6	M20	12	1110T
80R	15027	1800	170	190,00	180	0,144	172,7	259,6	–	370	–	381	119,4	140	270	225,4	327,9	320	2,39	–	–	45,5	6	M10	M6	M24	12	1120T
80R	15027	1800	190	190,00	193	0,240	175,5	259,6	–	370	–	381	134,6	140	270	238,1	327,9	347	2,39	–	–	45,5	6	M10	M6	M24	12	1130T

- ① **IMPORTANT: Upon removal of spacer hub, working clearance available for equipment removal = "BE" – "Z".**
Wrapflex is a metric product. Metric to inch conversions may not be direct. Dimensions are for reference and are subject to change without notice unless certified.
- ② 5R-50R nylon cover is standard and epoxy coated steel cover is optional. 60R-80R epoxy coated steel cover is standard (nylon cover not available).
- ③ For R10 hubs see **page 7** for "Max Bore Protruded Shaft" along with the footnote. Maximum Inch Bore listed is for a standard square key. For T shaft hubs only, larger inch bores with a rectangular key are available. Sizes 5R-50R are standard clearance fit with setscrew(s) over keyway. Sizes 60R - 80R are standard interference fit with keyway, but no setscrew. For interference fit with setscrew over keyway, refer to 427-105. For R10 hubs at the Max Bore condition, limit the number of start/stop cycles to 10 per hour unless long hubs are used.
- ④ Standard for T shaft hub is one setscrew over keyway; standard for R10 hub is two setscrews (one over keyway and one at 90° from keyway), Sizes 5-50R.
- ⑤ Flange fasteners are ISO Class 10.9 hex head cap screws for 5R thru 80R.
- ⑥ Maximum Inch Bore listed is for a standard square key. Larger bores, with a rectangular key, are available. Sizes 5R-50R are standard clearance fit with setscrew over keyway. Size 60R is standard interference fit with keyway, but no setscrew. For interference fit with setscrew over keyway, refer to 427-105.

R35 Standard Spacer Lengths

Coupling Size	BE	Z	Usable Clearance Gap
5R	54,44	9,0	45,44
	60,00	9,0	51,00
	65,57	9,0	56,57
	73,49	9,0	64,49
	90,00	9,0	81,00
10R	50,90	11,0	39,90
	62,00	11,0	51,00
	67,56	11,0	56,56
	75,51	11,0	64,51
	81,99	11,0	70,99
	90,00	11,0	79,00
	100,00	11,0	89,00
20R	104,09	11,0	93,09
	45,08	15,0	30,08
	52,57	15,0	37,57
	63,75	15,0	48,75
	75,84	15,0	60,84
	79,50	15,0	64,50
	86,00	15,0	71,00
	90,00	15,0	75,00
	100,00	15,0	85,00
	108,07	15,0	93,07

Coupling Size	BE	Z	Usable Clearance Gap
30R	59,24	17,0	42,24
	74,99	17,0	57,99
	87,99	17,0	70,99
	110,07	17,0	93,07
	127,00	17,0	110,00
40R	87,01	21,0	66,01
	93,51	21,0	72,51
	113,50	21,0	92,50
	115,58	21,0	94,58
	127,00	21,0	106,00
	147,33	21,0	126,33
50R	120,51	28,0	92,51
	122,57	28,0	94,57
	154,32	28,0	126,32
	157,50	28,0	129,50
60R	161,53	35,2	126,33

NOTE: Other BE lengths available. Refer to the Factory.

Taper-Lock bushing for R10 hub, see page 9.
QD bushing for R10 hub, see page 8.
Taper-Lock bushing for T shaft hub, see page 10.

NOTE: Dimensions subject to change. Certified dimensions of ordered material furnished on request.

(491-110M) 11

Bore Specifications and Keyways — All Rexnord Couplings

Recommended Hub Bores for Clearance & Interference Fit on Keyed Shafting Inch Shafts (Values are inch)

Shaft Dia.	Clearance Fit		Interference Fit		Shaft Dia.	Clearance Fit		Interference Fit		Shaft Dia.	Interference Fit	
	Hub Bore	Clearance	Hub Bore	Interference		Hub Bore	Clearance	Hub Bore	Interference		Hub Bore	Interference
+0.000	+0.010	.0000	+0.0005	.0000	+0.000	+0.015	.0000	+0.015	.0000	+0.000	+0.015	.0015
-.0005	-.0000	.0015	-.0000	.0010	-.0010	-.0000	.0025	-.0000	.0030	-.0010	-.0000	.0040
0.5000	0.5000	↓	0.4990	↓	3.0625	3.0625	↓	3.0595	↓	6.7500	6.7460	↓
0.5625	0.5625	↓	0.5615	↓	3.1250	3.1250	↓	3.1220	↓	7.0000	6.9960	↓
0.6250	0.625	↓	0.6240	↓	3.1875	3.1875	↓	3.1845	↓	+0.0000	+0.015	.0020
0.6875	0.6875	↓	0.6865	↓	3.2500	3.2500	↓	3.2470	↓	-.0010	-.0000	.0050
0.7500	0.7500	↓	0.7490	↓	3.3125	3.3125	↓	3.3095	↓	7.250	7.2450	↓
0.8125	0.8125	↓	0.8115	↓	3.3750	3.3750	↓	3.3720	↓	7.500	7.4950	↓
0.8750	0.8750	↓	0.8740	↓	3.4375	3.4375	↓	3.4350	↓	7.750	7.7450	↓
0.9375	0.9375	↓	0.9365	↓	3.5000	3.5000	↓	3.4970	↓	8.000	7.9950	↓
1.0000	1.0000	↓	0.9990	↓	3.5625	3.5625	↓	3.5595	↓	8.250	8.2445	.0025
1.0625	1.0625	↓	1.0615	↓	3.6250	3.6250	↓	3.6220	↓	8.500	8.4945	.0055
1.1250	1.1250	↓	1.1240	↓	3.6875	3.6875	↓	3.6845	↓	8.750	8.7445	↓
1.1875	1.1875	↓	1.1865	↓	3.7500	3.7500	↓	3.7470	↓	9.000	8.9945	↓
1.2500	1.2500	↓	1.2490	↓	3.8125	3.8125	↓	3.8095	↓	9.250	9.2440	.0030
1.3125	1.3125	↓	1.3115	↓	3.8750	3.8750	↓	3.8720	↓	9.500	9.4940	.0060
1.3750	1.3750	↓	1.3740	↓	3.9375	3.9375	↓	3.9345	↓	9.750	9.7440	↓
1.4375	1.4375	↓	1.4365	↓	4.0000	4.0000	↓	3.9970	↓	10.000	9.9940	↓
1.5000	1.5000	↓	1.4990	↓	4.0625	4.0625	↓	4.0590	↓	10.250	10.2435	.0035
+0.0000	+0.010	.0000	+0.0010	.0000	-.0010	-.0000	.0025	-.0000	.0035	10.500	10.4935	.0065
-.0010	-.0000	.0020	-.0000	.0020	4.0625	4.0625	↓	4.0590	↓	10.750	10.7435	↓
1.5625	1.5625	↓	1.5605	↓	4.1250	4.1250	↓	4.1215	↓	11.000	10.9935	↓
1.6250	1.6250	↓	1.6230	↓	4.1875	4.1875	↓	4.1840	↓	11.250	11.2430	.0040
1.6875	1.6875	↓	1.6855	↓	4.2500	4.2500	↓	4.2465	↓	11.500	11.4930	.0070
1.7500	1.7500	↓	1.7480	↓	4.3125	4.3125	↓	4.3090	↓	11.750	11.7430	↓
1.8125	1.8125	↓	1.8105	↓	4.3750	4.3750	↓	4.3715	↓	12.000	11.9930	↓
1.8750	1.8750	↓	1.8730	↓	4.5000	4.5000	↓	4.4965	↓	12.500	12.4925	.0045
1.9375	1.9375	↓	1.9355	↓	4.5625	4.5625	↓	4.5590	↓	13.000	12.9925	.0075
2.0000	2.0000	↓	1.9980	↓	4.6250	4.6250	↓	4.6215	↓	+0.0000	+0.020	.0050
+0.0000	+0.015	.0000	+0.0010	.0000	4.6875	4.6875	↓	4.6840	↓	-.0015	-.0000	.0085
-.0010	-.0000	.0025	-.0000	.0020	4.7500	4.7500	↓	4.7465	↓	13.500	13.4915	↓
2.0625	2.0625	↓	2.0605	↓	4.8125	4.8125	↓	4.8090	↓	14.000	13.9915	↓
2.1250	2.1250	↓	2.1230	↓	4.8750	4.8750	↓	4.8715	↓	14.500	14.4910	.0055
2.1875	2.1875	↓	2.1855	↓	4.9375	4.9375	↓	4.9340	↓	15.000	14.9910	.0090
2.2500	2.2500	↓	2.2480	↓	5.0000	5.0000	↓	4.9965	↓	+0.0000	+0.025	.0060
2.3125	2.3125	↓	2.3105	↓	5.0625	5.0625	↓	5.0585	.0015	-.0015	-.0000	.0100
2.3750	2.3750	↓	2.3730	↓	5.1250	5.1250	↓	5.1210	.0040	15.000	15.4900	↓
2.4375	2.4375	↓	2.4355	↓	5.1875	5.1875	↓	5.1835	↓	16.000	15.9900	↓
2.5000	2.5000	↓	2.4980	↓	5.2500	5.2500	↓	5.2460	↓	16.500	16.4895	.0065
2.5625	2.5625	↓	2.5605	↓	5.3125	5.3125	↓	5.3085	↓	17.000	16.9895	.0105
2.6250	2.6250	↓	2.6230	↓	5.3750	5.3750	↓	5.3710	↓	17.500	17.4890	.0070
2.6875	2.6875	↓	2.6855	↓	5.4375	5.4375	↓	5.4335	↓	18.000	17.9890	.0110
2.7500	2.7500	↓	2.7480	↓	5.5000	5.5000	↓	5.4960	↓	18.500	18.4890	↓
2.8125	2.8125	↓	2.8105	↓	5.5625	5.5625	↓	5.5585	↓	19.000	18.9890	↓
2.8750	2.8750	↓	2.8730	↓	5.6250	5.6250	↓	5.6210	↓	19.500	19.4880	.0080
2.9375	2.9375	↓	2.9355	↓	5.6875	5.6875	↓	5.6835	↓	20.000	19.9880	.0120
3.0000	3.0000	↓	2.9980	↓	5.7500	5.7500	↓	5.7460	↓			
					5.8125	5.8125	↓	5.8085	↓			
					5.8750	5.8750	↓	5.8710	↓			
					5.9375	5.9375	↓	5.9335	↓			
					6.0000	6.0000	↓	5.9960	↓			
					6.2500	6.2500	↓	6.2460	↓			
					6.5000	6.5000	↓	6.4960	↓			

NOTE: Consult Rexnord for all keyless bore fits.

Recommended Commercial Keys for Bores with One Key (in/mm)

Inches (Per ANSI B17.1 Standard)												
Shaft Dia		Key	Shaft Dia		Key	Shaft Dia		Key	Shaft Dia		Key	
Over	Through		Over	Through		Over	Through		Over	Through		
0.438	0.562	0.125 x 0.125	1.750	2.250	0.500 x 0.500	4.500	5.500	1.250 x 1.250	11.000	13.000	3.000 x 2.000	
0.562	0.875	0.188 x 0.188	2.250	2.750	0.625 x 0.625	5.500	6.500	1.500 x 1.500	13.000	15.000	3.500 x 2.500	
0.875	1.250	0.250 x 0.250	2.750	3.250	0.750 x 0.750	6.500	7.500	1.750 x 1.500	15.000	18.000	4.000 x 3.000	
1.250	1.375	0.312 x 0.312	3.250	3.750	0.875 x 0.875	7.500	9.000	2.000 x 1.500	18.000	20.000	5.000 x 3.500	
1.375	1.750	0.375 x 0.375	3.750	4.500	1.000 x 1.000	9.000	11.000	2.500 x 1.750	-	-	-	
Millimeters (Per ISO R773 Standard)												
6	8	2 x 2	38	44	12 x 8	95	110	28 x 16	260	290	63 x 32	
8	10	3 x 3	44	50	14 x 9	110	130	32 x 18	290	330	70 x 36	
10	12	4 x 4	50	58	16 x 10	130	150	36 x 20	330	380	80 x 40	
12	17	5 x 5	58	65	18 x 11	150	170	40 x 22	380	440	90 x 45	
17	22	6 x 6	65	75	20 x 12	170	200	45 x 25	440	500	100 x 50	
22	30	8 x 7	75	85	22 x 14	200	230	50 x 28	-	-	-	
30	38	10 x 8	85	95	25 x 14	230	260	56 x 32	-	-	-	

12 (491-110M)

NOTE: Dimensions subject to change. Certified dimensions of ordered material furnished on request.



Bore Specifications and Keyways — All Rexnord Couplings

Recommended Bore Tolerances Falk Steel Coupling Hubs — Millimeters

Shaft Diameter (ISO/R775-1969)		Bore Diameter Tolerance		
Nominal	Tolerance	Clearance	Transitional	Interference
6 to 30	j6 / k6 [ⓐ]	F7	H7	M6
Over 30 to 50	k6	F7	H7	K6
Over 50 to 80	m6	F7	H7	K7
Over 80 to 100	m6	F7	H7	M7
Over 100 to 200	m6	F7	H7	P7
Over 200 to 355	m6	F7	H7	R7
Over 355 to 500	m6	F7	H7	R8

[ⓐ] Per DIN 748 — Differs from ISO/R775.

Recommended Bores for Metric Shafts per ISO/R775–1969 (ANSI/AGMA 9112) (mm)

	Shaft Diameter	Clearance Fit		Transitional Fit		Interference Fit	
		Hub Bore	Fit [ⓐ]	Hub Bore	Fit [ⓐ]	Hub Bore	Fit [ⓐ]
	j6	F7	+ 0,008	H7	- 0,008	M6	- 0,023
mm	+ 0,008 / - ,003	+ 0,016 / + ,034	+ 0,037	+ 0,000 / + 0,018	+ 0,021	- ,015 / - ,004	- 0,001
12	12,008/11,997	12,016/12,034	↓	12,000/12,018	↓	11,985/11,996	↓
14	14,008/13,997	14,016/14,034	↓	14,000/14,018	↓	13,985/13,996	↓
16	16,008/15,997	16,016/16,034	↓	16,000/16,018	↓	15,985/15,996	↓
18	18,008/17,997	18,016/18,034	↓	18,000/18,018	↓	17,985/17,996	↓
	j6	F7	+ 0,011	H7	- 0,009	M6	- 0,026
mm	+ 0,009 / - 0,004	+ 0,020 / + 0,041	+ 0,045	+ 0,000 / + 0,021	+ 0,025	- 0,017 / - 0,004	+ 0,000
19	19,009/18,996	19,020/19,041	↓	19,000/19,021	↓	18,983/18,996	↓
20	20,009/19,996	20,020/20,041	↓	20,000/20,021	↓	20,983/20,996	↓
22	22,009/21,996	22,020/22,041	↓	22,000/22,021	↓	21,983/21,996	↓
24	24,009/23,996	24,020/24,041	↓	24,000/24,021	↓	23,983/23,996	↓
25	25,009/24,996	25,020/25,041	↓	25,000/25,021	↓	24,983/24,996	↓
28	28,009/27,996	28,020/28,041	↓	28,000/28,021	↓	27,983/27,996	↓
30	30,009/29,996	30,020/30,041	↓	30,000/30,021	↓	29,983/29,996	↓
>30	k6	F7	+ 0,007	H7	- 0,018	K6	- 0,031
mm	+ 0,018 / + ,002	+ 0,025 / + 0,050	+ 0,048	+ 0,000 / + 0,025	+ 0,023	- 0,013 / + 0,003	+ 0,001
32	32,018/32,002	32,025/32,050	↓	32,000/32,025	↓	31,987/32,003	↓
35	35,018/35,002	35,025/35,050	↓	35,000/35,025	↓	34,987/35,003	↓
38	38,018/38,002	38,025/38,050	↓	38,000/38,025	↓	37,987/38,003	↓
40	40,018/40,002	40,025/40,050	↓	40,000/40,025	↓	39,987/40,003	↓
42	42,018/42,002	42,025/42,050	↓	42,000/42,025	↓	41,987/42,003	↓
45	45,018/45,002	45,025/45,050	↓	45,000/45,025	↓	44,987/45,003	↓
48	48,018/48,002	48,025/48,050	↓	48,000/48,025	↓	47,987/48,003	↓
50	50,018/50,002	50,025/50,050	↓	50,000/50,025	↓	49,987/50,003	↓
>50	m6	F7	+ 0,000	H7	- 0,030	K7	- 0,051
mm	+ 0,030 / + 0,011	+ 0,030 / + 0,060	+ 0,049	+ 0,000 / + 0,030	+ 0,019	- 0,021 / + 0,009	- 0,002
55	55,030/55,011	55,030/55,060	↓	55,000/55,030	↓	54,979/55,009	↓
56	56,030/56,011	56,030/56,060	↓	56,000/56,030	↓	55,979/56,009	↓
60	60,030/60,011	60,030/60,060	↓	60,000/60,030	↓	59,979/60,009	↓
63	63,030/63,011	63,030/63,060	↓	63,000/63,030	↓	62,979/63,009	↓
65	65,030/65,011	65,030/65,060	↓	65,000/65,030	↓	64,979/65,009	↓
70	70,030/70,011	70,030/70,060	↓	70,000/70,030	↓	69,979/70,009	↓
71	71,030/71,011	71,030/71,060	↓	71,000/71,030	↓	70,979/71,009	↓
75	75,030/75,011	75,030/75,060	↓	75,000/75,030	↓	74,979/75,009	↓
80	80,030/80,011	80,030/80,060	↓	80,000/80,030	↓	79,979/80,009	↓
>80	m6	F7	+ 0,001	H7	- 0,035	M7	- 0,070
mm	+ 0,035 / + 0,013	+ 0,036 / + 0,071	+ 0,058	+ 0,000 / + 0,035	+ 0,022	- 0,035 / + 0,000	- 0,013
85	85,035/85,013	85,036/85,071	↓	85,000/85,035	↓	84,965/85,000	↓
90	90,035/90,013	90,036/90,071	↓	90,000/90,035	↓	89,965/90,000	↓
95	95,035/95,013	95,036/95,071	↓	95,000/95,035	↓	94,965/95,000	↓
100	100,035/100,013	100,036/100,071	↓	100,000/100,035	↓	99,965/100,000	↓
>100	m6	F7		H7		P7	- 0,094
mm	+ 0,035 / + 0,013	+ 0,036 / + 0,071		+ 0,000 / + 0,035		- 0,059 / - 0,024	- 0,037
110	110,035/110,013	110,036/110,071	↓	110,000/110,035	↓	109,941/109,976	↓
120	120,035/120,013	120,036/120,071	↓	120,000/120,035	↓	119,941/119,976	↓
>120	m6	F7	+ 0,003	H7	- 0,040	P7	- 0,108
mm	+ 0,040 / + 0,015	+ 0,043 / + 0,083	+ 0,068	+ 0,000 / + 0,040	+ 0,025	- 0,068 / - 0,028	- 0,043
125	125,040/125,015	125,043/125,083	↓	125,000/125,040	↓	124,932/124,972	↓
130	130,040/130,015	130,043/130,083	↓	130,000/130,040	↓	129,932/129,972	↓
140	140,040/140,015	140,043/140,083	↓	140,000/140,040	↓	139,932/139,972	↓
150	150,040/150,015	150,043/150,083	↓	150,000/150,040	↓	149,932/149,972	↓
160	160,040/160,015	160,043/160,083	↓	160,000/160,040	↓	159,932/159,972	↓
170	170,040/170,015	170,043/170,083	↓	170,000/170,040	↓	169,932/169,972	↓
180	180,040/180,015	180,043/180,083	↓	180,000/180,040	↓	179,932/179,972	↓
>180	m6	F7	+ 0,004	H7	- 0,046	P7	- 0,125
mm	+ 0,046 / + 0,017	+ 0,050 / + 0,096	+ 0,079	+ 0,000 / + 0,046	+ 0,029	- 0,079 / - 0,033	- 0,050

[ⓐ] Positive values are clearance, negative values are interference. For reference only.

NOTE: Dimensions subject to change. Certified dimensions of ordered material furnished on request.

(491-110M) 13

Mill Motor Selection

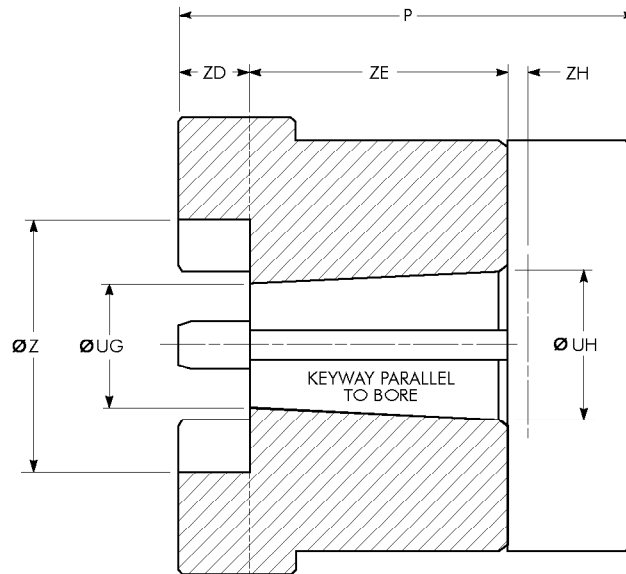

Standard AISE AC & DC Mill Motor Coupling Selections (mm)

Motor Frame Sizes			Coupling Size	Torque Rating (Nm)	Ø UG	Ø UH	Ø Z	Keyway	ZD	ZE	ZH +.xxx -.000		
602	802 A,B,C	AC 1, 2, 4	40R ⊕	1028	36,53	44,45	80,8	12,7 X 6,35	21,08	76,2	0,61		
			50R	2508								106	27,94
603, 604	803, 804	-	50R	2508	41,53	50,8	106	12,7 X 6,35	27,94	88,9	0,74		
			60R	4011								135	35,31
			50R ⊕	2508								106	27,94
606	806	AC 8, 12	60R	4011	52,91	63,5	135	12,7 X 6,35	35,31	101,6	0,74		
			70R	8011								160	39,62
			60R	4011								135	35,31
608	808	-	70R	8011	64,28	76,2	160	19,1 X 6,35	39,62	114,3	0,74		
			80R	15027								190	45,47
			70R	8011								160	39,62
610	810	AC 18	80R	15027	70,64	82,55	190	19,1 X 6,35	45,47	114,3	0,86		
			70R	8011								160	39,62
612	812	AC 25, 30	70R	8011	78,84	92,08	160	19,1 X 6,35	39,62	127	0,86		
			80R	15027								190	45,47
614	814	AC 40, 50	80R	15027	94,72	107,95	190	25,4 X 9,53	45,47	127	0,86		

Taper & Counter Bore Limitations (mm)

Coupling Size	P Max	Ø UG Min	Ø UH Max	Ø Z Max	ZD Max	ZE Min	Keyway ⊕
5R	60,96	12,7	38,1	38,99	9,19	21,01	9,52 x 0 4,78
10R	78,99	12,7	44,45	46,0	11,2	25,4	9,52 x 0 4,78
20R	104,9	19,05	57,15	58,7	15,19	27,0	12,7 X 6,35
30R	133,1	25,4	63,5	65	17,2	34,01	15,88 x 7,95
40R	154,94	28,58	79,38	80,8	21,21	34,01	19,1 x 4,78
50R	182,12	28,58	104,78	105,99	28,19	46,0	25,4 x 12,7
60R	185,17	31,75	133,35	135,0	35,41	54,0	31,75 x 15,88
70R	219,71	38,1	155,58	159,99	39,9	57,0	38,1 x 19,1
80R	255,52	38,1	184,15	189,99	45,59	66,50	44,45 x 22,23

- ⊕ Must use "standard" socket on mill motor nut. "Impact" socket will not fit.
 ⊗ Keyway shown is for maximum bore with square key.

Type R10 Mill Motor Hubs

Mill Motor Frame Size			R10 Flex Hubs								
			5R	10R	20R	30R	40R	50R	60R	70R	80R
602	802 A, B, C	AC 1, 2 & 4	-	-	-	-	X	X	-	-	-
			-	-	-	-	Consult Rexnord	X	X	-	-
603 604	803 804	AC 8 & 12	-	-	-	-	-	-	X	X	X
			-	-	-	-	-	-	X	X	X
606	806	AC 18	-	-	-	-	-	-	Consult Rexnord	X	X
608	808	AC 25 & 30	-	-	-	-	-	-	-	X	X
610	810	AC 40 & 50	-	-	-	-	-	-	-	X	X
612	812	AC 40 & 50	-	-	-	-	-	-	-	X	X
614	814	AC 40 & 50	-	-	-	-	-	-	-	X	X

Misalignment Capacity, Mass & WR²

Installation & Operating Misalignment Capacity (See graph for combined limits)

Coupling Size	Installation Limits		Operating Limits	
	Parallel Offset (mm)	Angular (degree)	Parallel Offset (mm)	Angular (degree)
5R	0,50	0,25	1,00	1,00
10R	0,50	0,25	1,00	1,00
20R	1,00	0,25	2,00	1,00
30R	1,00	0,25	2,00	1,00
40R	1,00	0,25	2,00	1,00
50R	1,00	0,25	2,00	1,00
60R	1,00	0,25	2,00	1,00
70R	1,00	0,25	2,00	1,00
80R	1,00	0,25	2,00	1,00

70D Black Insert		
Used With	Torque	Temp (C)
Nylon Cover	+ 25%	107
Steel Cover	+ 35%	121

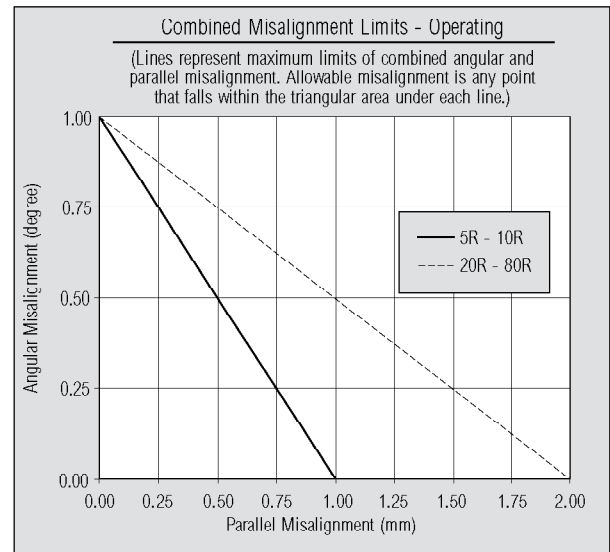

Mass & WR²

Coupling Size	R10 Mass					
	Element (kg)	Nylon Cover (kg)	Steel Cover (kg)	R10 Hub (No Bore) (kg)	Total w/Nylon Cover (kg)	Total w/Steel Cover (kg)
5R	0,032	0,031	0,17	0,64	1,34	1,48
10R	0,059	0,050	0,28	1,19	2,49	2,71
20R	0,19	0,13	0,59	2,65	5,61	6,07
30R	0,29	0,17	0,83	4,46	9,37	10,0
40R	0,59	0,39	1,42	8,03	17,0	18,1
50R	1,22	0,77	2,64	16,9	35,7	37,6
60R	1,85	-	3,31	30,4	-	66,0
70R	2,80	-	4,63	51,7	-	111
80R	4,63	-	6,62	77,1	-	165

Coupling Size	R10 WR ² ②					
	Element (kg-m ²)	Nylon Cover (kg-m ²)	Steel Cover (kg-m ²)	R10 Hub (No Bore) (kg-m ²)	Total w/Nylon Cover (kg-m ²)	Total w/Steel Cover (kg-m ²)
5R	0,000026	0,000041	0,00022	0,00031	0,00068	0,00086
10R	0,000067	0,000094	0,00051	0,00082	0,0018	0,0022
20R	0,00040	0,00046	0,0021	0,0031	0,0070	0,0086
30R	0,00080	0,00082	0,0039	0,0068	0,015	0,018
40R	0,0026	0,0030	0,010	0,019	0,044	0,051
50R	0,0089	0,0093	0,031	0,072	0,16	0,18
60R	0,020	-	0,055	0,18	-	0,44
70R	0,041	-	0,10	0,44	-	1,02
80R	0,098	-	0,22	0,86	-	2,04

Coupling Size	T31 Shaft Hub	R31/R35 WR ² Values ①							
		Min BE (mm)	R31 Assembly ②		WR ² (kg-m ²) per mm	Min BE (mm)	R35 Assembly ③		WR ² (kg-m ²) per mm
			Nylon Cover	Steel Cover			Nylon Cover	Steel Cover	
5R	1020	81,0	0,00220	0,00239	0,0000040	50,5	0,00144	0,00162	0,0000040
10R	1030	89,0	0,00398	0,00439	0,0000048	59,7	0,00281	0,00322	0,0000048
20R	1040	89,0	0,0115	0,0131	0,000014	76,5	0,0097	0,0112	0,000014
30R	1050	111,1	0,0212	0,0241	0,000023	87,6	0,0193	0,0222	0,000023
40R	1070	127,0	0,0635	0,0711	0,000048	88,6	0,0538	0,0612	0,000048
50R	1080	165,2	0,169	0,191	0,00012	113,0	0,165	0,187	0,00012
60R	1090	200,0	-	0,439	0,00023	137,7	-	0,439	0,00023
70R	1100	223,6	-	0,869	0,00047	154,0	-	0,945	0,00047
70R	1110	223,6	-	1,06	0,00047	154,0	-	1,04	0,00047
80R	1120	248,5	-	2,24	0,00071	172,6	-	2,11	0,00071
80R	1130	254,1	-	2,81	0,0017	175,4	-	2,40	0,0017

① WR² values are based on hubs with no bore.

② For R31 Mass, refer to **page 10**.

③ For R35 Mass, refer to **page 11**.



866-REXNORD/866-739-6673 (Within the US)
414-643-2366 (Outside the US)
www.rexnord.com

Why Choose Rexnord?

When it comes to providing highly engineered products that improve productivity and efficiency for industrial applications worldwide, Rexnord is the most reliable in the industry. Commitment to customer satisfaction and superior value extend across every business function.

Delivering Lowest Total Cost of Ownership

The highest quality products are designed to help prevent equipment downtime and increase productivity and dependable operation.

Valuable Expertise

An extensive product offering is accompanied by global sales specialists, customer service and maintenance support teams, available anytime.

Solutions to Enhance Ease of Doing Business

Commitment to operational excellence ensures the right products at the right place at the right time.



Rexnord Corporation

Rexnord is a growth-oriented, multi-platform industrial company with leading market shares and highly trusted brands that serve a diverse array of global end markets.

Process and Motion Control

The Rexnord Process & Motion Control platform designs, manufactures, markets and services specified, highly engineered mechanical components used within complex systems where our customers' reliability requirements and the cost of failure or downtime are extremely high.

Water Management

The Rexnord Water Management platform designs, procures, manufactures and markets products that provide and enhance water quality, safety, flow control and conservation.



Sociedad Industrial de Transmisiones S.A.
Pº Ubarburu, 67
20014 San Sebastián
Tfno. 943 457200 | www.sitsa.es | atencioncliente@sitsa.es