



VOITH

Torque-limiting for Increased
Reliability in Steel Production.
SafeSet Torque-limiting Couplings
and Connection Couplings.





Protect the Driveline, Perfect the Steel

The steel production process should be the same as the metal it produces; smooth, strong and reliable. Torque-limiting couplings can increase the operating efficiency, reduce downtime and operational costs.

Continuous production with a constant and even flow is essential when handling heavy loads in the construction of flat, long and strip steel products.

In steel production, world leading torque-limiting couplings from Voith protect big and heavy machinery by releasing or slipping at a very precise set torque. Connection couplings are used for torque transmitting, often in straightening and levelling.

Our couplings avoid machinery damage caused by overload, improve processes and increase production. To ensure best possible use, every coupling is specifically adapted for the application intended.

Torque-limiting couplings and connection couplings from Voith:

- Protect equipment, which leads to financial savings
- Increase production uptime, which also increases profit
- Lengthen the life span of the machinery by avoiding overload cases
- Provide a backlash free connection
- Reduce wear on the rolls



- 1 Rolling Mill
- 2 Leveller

Plate Mills

The key to producing steel plate is carefully controlling the rolling and cooling processes in order to ensure dimensional accuracy and faultless surfaces. A precise rolling force is required to achieve the necessary deformation of the rolled material. If the torque is too high and an overload occurs, it can lead to production downtime.

Installing a SafeSet between the rollers and the gear box controls and limits the torque to ensure smooth production of a plate with integral strength and evenness and minimized shape defects.

A constant and even production process is also required when leveling and straightening any faults in the plate. Torque and speed variations cause slippage between the plate and rolls, which can create further buckling, wrinkles or even fractures to the plate.

To achieve an unstressed, even material, an AutoSet can be installed on the pinion shafts, which makes micro slippages to reduce high torque peaks.

Heavy plate mill main drive with SafeSet

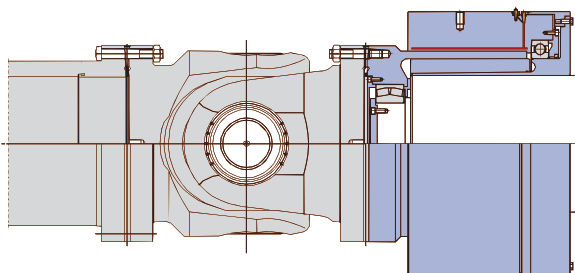

Leveller spindle with AutoSet

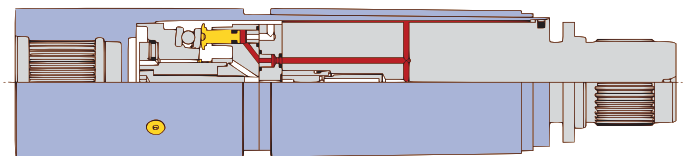

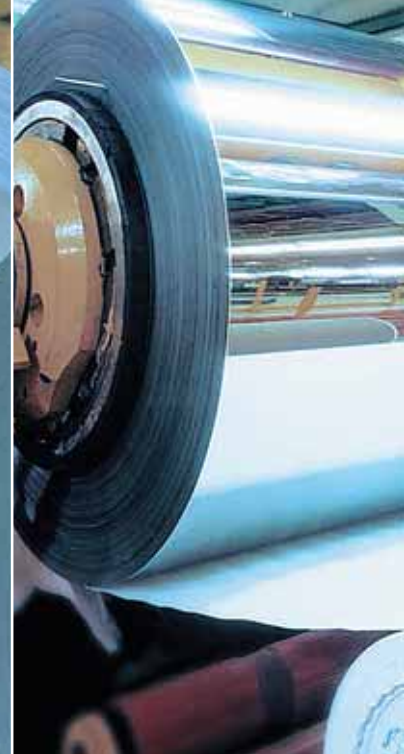

1 SR-F 560 Integrated with gear spindles in a stripmill

Strip Mills

Intense performance demands are put on the driveline due to the high loads applied, caused by the need for steel deformation during the production process. It is important to protect the driveline from catastrophic torque overloading and slippage between the rolls and strip. These can cause

severe production downtime or slipping marks on the strip and wear of the rolls. SafeSet torque-limiting couplings provide protection for all driveline components in the event of torque peaks and prevent slippage on the strip.

SR-F integrated with gear spindle

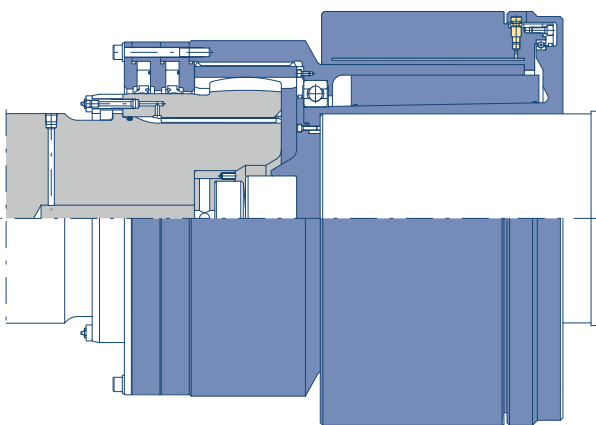



1

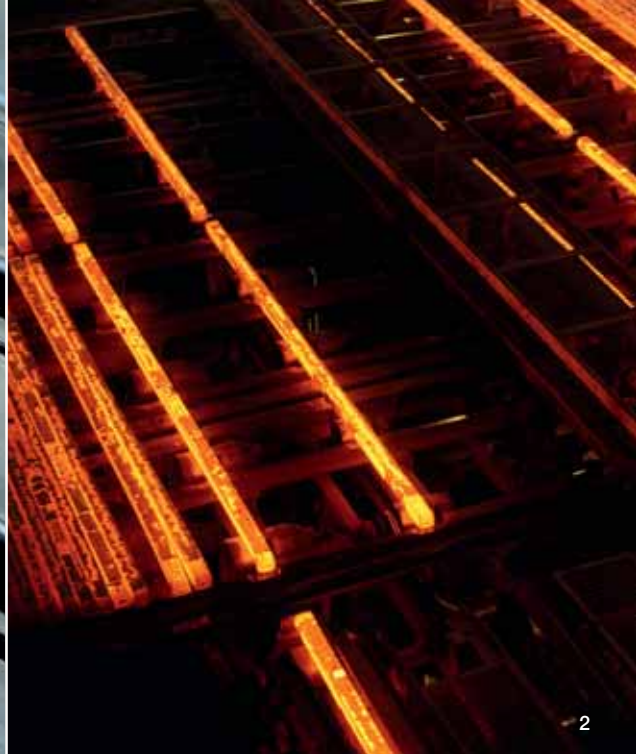

2

- 1 Beams
- 2 Rail

Long Steel Products

Preventing torque overloads and possible damage to the drive-line and rollers ensures the smooth, continuous production of long steel products and tubes. Torque overloads can create a huge backlash between the coupling box and flat roll end which could lead to possible shattering problems.

By installing a SafeSet backlash free connection coupling on the flat rollend, you can achieve a better surface control of rolled plates. This also extends the life of the driveline, reduces downtime and minimizes the risk of shattering.

Compact design for narrow build-ins

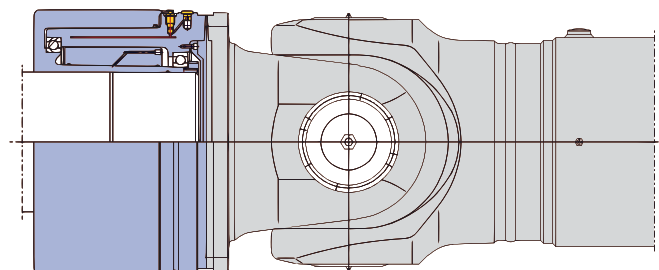

Connection coupling in a rail straightener

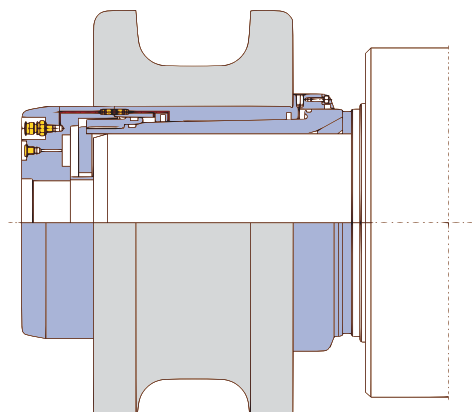



1 SR-F 800 disassembling

2 Service and overhaul of SR-F 800

Service and Maintenance

The key to maintaining the highest continuous operating performance and prolonged life of all components is scheduled servicing. This ensures the couplings operate with the same accuracy as when they were first installed.

Correct installation and training of maintenance personnel is equally important to ensure optimum reliability, whether it is a rolling mill, a leveller or a conveyor. Voith assist during installation, initial start-up and final commissioning. We train your personnel to operate the couplings and optimize performance to maintain constant reliability, ensuring the SafeSet fulfills its designed potential.

A case study shows that correct servicing, guarantees the continued accuracy of the couplings. At Columbus Stainless LTD in South Africa, two SafeSets had been in operation for 18 years. The Voith service team carried out an extended service on the couplings.

A post verification test shown on the next page revealed that the SafeSets were limiting the torque with the same accuracy as when they were installed.

Example of a typical service scope:

Standard service, after 2-3 years

- External inspection for damage
- Function control
- Exchange of oil/oil wash/wear parts
- Inspection of shear tube seat or pumps
- Calibration of pumps and torque wrench
- Pressure proof test
- Training of customer personnel

Extended service, after 5-7 years; all the points above plus

- Disassembly
- Interior cleaning, inspection and surface overhaul
- Replacement of worn parts
- Re-assembly and function control
- Training of customer personnel
- Post verification test



SOCIEDAD INDUSTRIAL DE TRANSMISIONES S.A.
Pº Ubarburu, 67 - 20014 San Sebastián
Tfno. 943 457200 | Fax 943 463356
www.sitsa.es
atencioncliente@sitsa.es
09_02_07

Voith Turbo SafeSet AB
Rönningevägen 8
82434 Hudiksvall, Sweden
Tel. +46 650 540150
Fax +46 650 540165
info.safeset@voith.com
www.voith.com

VOITH
Engineered Reliability