



Spring-Engaged Rod/Shaft Lock

RLSSB-S

RLSSB-C

RLSSB-C-MR



RLSSB-S-MR



In accordance with Nexen's established policy of constant product improvement, the specifications contained in this manual are subject to change without notice. Technical data listed in this manual are based on the latest information available at the time of printing and are also subject to change without notice.

Technical Support: 800-843-7445
(651) 484-5900

www.nexengroup.com

	<p style="text-align: center;"> DANGER</p> <p>Read this manual carefully before installation and operation. Follow Nexen's instructions and integrate this unit into your system with care. This unit should be installed, operated and maintained by qualified personnel ONLY. Improper installation can damage your system, cause injury or death. Comply with all applicable codes.</p>	
---	---	---

This document is the original, non-translated, version.

Conformity Declaration: In accordance with Appendix II B of CE Machinery Directive (2006/42/EC):

A Declaration of Incorporation of Partly Completed Machinery evaluation for the applicable EU directives was carried out for this product in accordance with the Machinery Directive. The declaration of incorporation is set out in writing in a separate document and can be requested if required.

This machinery is incomplete and must not be put into service until the machinery into which it is to be incorporated has been declared in conformity with the applicable provisions of the Directive.

Nexen Group, Inc.
560 Oak Grove Parkway
Vadnais Heights, Minnesota 55127

ISO 9001 Certified

Copyright 2011 Nexen Group, Inc.

Table of Contents

General Specifications	4
General Safety Precautions	4
Installation	5
Rod Material	6
Lubrication	6
Optional Locking Mode Sensor	7
Air Connections	7
Air Controls and Programming	8
Manual Release	9
Service Recommendation	10
Warranty	10

GENERAL SPECIFICATIONS

Specifications:	
Holding Force	Up to 22350 N (5026 lbs)
Actuation Pressure	1 - 5.5 bar (14.5 - 120 psi)
External Temp. Limits	0.5 - 66 C (33 - 150 F)
Approximate Weight	Up to 29.5 kg (65 lbs)

GENERAL SAFETY PRECAUTIONS



CAUTION

Use lifting aids and proper lifting techniques when installing, removing, or placing this product in service.



CAUTION

Do not exceed the maximum holding force of the unit. The locking function will be overloaded, causing rod slip and possible damage to the shaft and product.



CAUTION

Watch for sharp features when interacting with this product. The parts have complex shapes and machined edges.



CAUTION

Do not use a Rod Lock to stop a rotating shaft. This product is not intended for torsional braking or frequent dynamic braking.



WARNING

Ensure proper guarding of the product is used. Nexen recommends the machine builder design guarding in compliance with OSHA 29 CFR 1910 "Occupational Safety and Health Hazards".

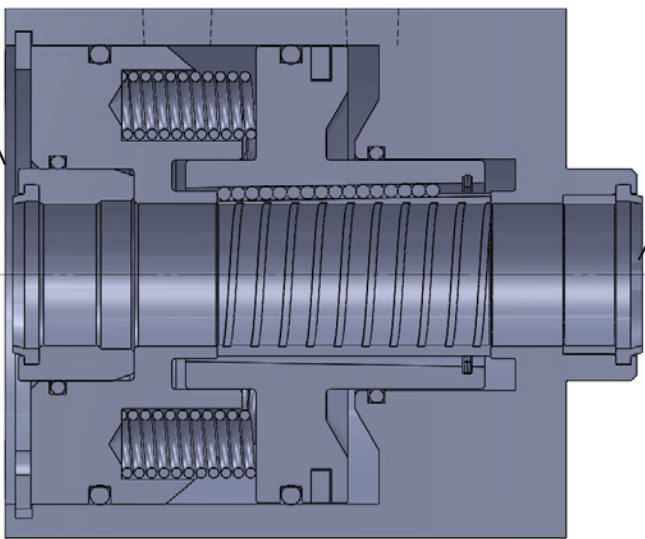



CAUTION

Do not attempt to disassemble this product. Product components are spring-loaded and can cause serious injury.



CAUTION

Do not engage the Rod Lock without a properly sized rod in place or damage to the internal components may result.

INSTALLATION

NOTE: “Rod” and “Shaft” refer to the same feature and are used interchangeably.

The “S” (stand-alone) series Rod Locks are designed to mount on round guide rods and are typically mounted in accordance with the design of the machine.

The “C” (cylinder) series Rod Locks are designed to mount directly to NFPA or ISO flush-mount air cylinders. The “C” -mounted Rod Locks come with (4) mounting screws. These screws are used to attach the Rod Lock to cylinders with tapped holes in the interface or with socket head, sleeve nuts. The mounting screws are not necessary on cylinders equipped with threaded tie rods / nuts. Cylinders should be prepared with enough rod length and tie rod length (if appropriate) to accommodate the rod lock length.

1. Apply a constant supply of air, with a minimum of 4.1 bar (60 psi) air pressure to open (release) the Rod Lock. Manual release option; apply the appropriate amount of torque to the manual override mechanism to open (release) the Rod Lock.
2. Remove the supplied rod from the inside of the Rod Lock and keep for future use.

3. Carefully slide the Rod Lock over the cylinder rod or guide rod, past the seal(s) and through the entire assembly. Note: Cylinder (“C”) mounts, skip to instruction #5.
4. “S” (stand-alone) series: Remove the air pressure to engage the Rod Lock on the guide rod when it is in the desired position.
5. “C” (cylinder mount) series: Carefully slide the Rod Lock onto the cylinder rod toward the cylinder end cap. The Rod Lock is piloted and sealed to the gland O.D., so some force is required. Press the Rod Lock onto the end cap face as close as possible.
6. Using a corner-to-corner sequence, install and tighten the mounting screws or tie rod nuts to approximately 75% of the final tightening torque. (See Table 1)
7. Using a calibrated torque wrench, tighten the fasteners or nuts to the final torque specification using the same corner-to-corner sequence.
8. Remove the air pressure to engage the Rod Lock on the cylinder rod.

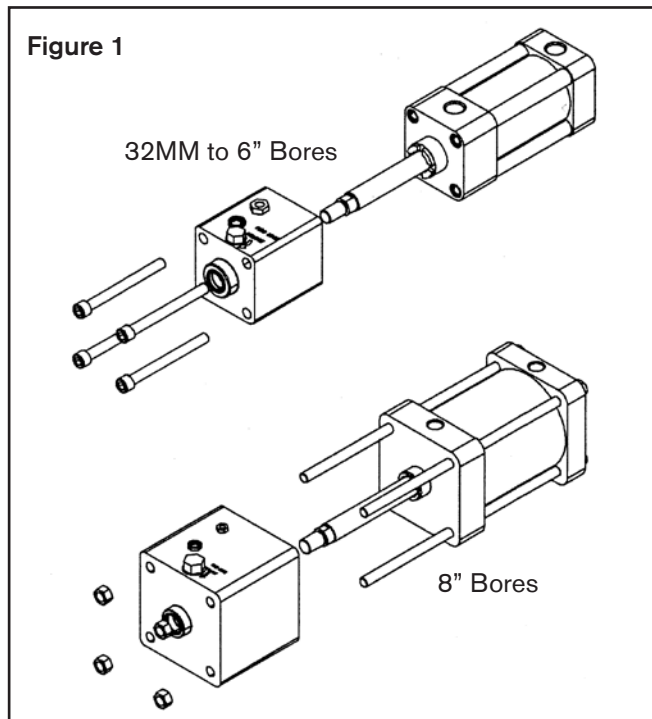
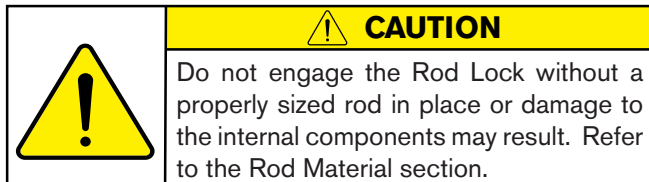

Table 1 Fastener or Tie Rod Torque

Rod Lock	Inch-Pounds	Nm
RLSSB 150-063	32-36	3.6-4.1
RLSSB 200-063	72-82	8-9
RLSSB 200-100	72-82	8-9
RLSSB 250-063	72-82	8-9
RLSSB 325-100	216-228	24-25.3
RLSSB 400-100	216-228	24-25.3
RLSSB 400-138	216-228	24-25.3
RLSSB 500-100	360-372	41-42
RLSSB 500-138	360-372	41-42
RLSSB 600-138	420-432	48-49
RLSSB 600-175	420-432	48-49
RLSS 800-138	960-972	109-115
RLSS 800-175	960-972	109-115
RLSS 800-250	960-972	109-115
RLSSB 032-012	30-38	3.4-4.3
RLSSB 040-016	30-38	3.4-4.3
RLSSB 050-020	66-100	7.5-11.3
RLSSB 063-020	66-100	7.5-11.3
RLSSB 080-025	156-230	18-26
RLSSB 100-025	156-230	18-26
RLSSB 125-032	400	45

ROD MATERIAL

- Nexen strongly recommends the following rod material for cylinder rods and guide rods. Deviations from these specifications will result in poor rod lock performance and shaft damage.

Hardness Specification	Hard Chrome Plating Thickness
Less than 52 HRC	20 microns [0.0008 inch]
Greater than 52 HRC	8-3 microns [0.0003- 0.0005 inch]

- The diameter should lie in the h8 tolerance range.
Reference: USAS B4.1 - 1967(1974)
ISO 286-1 - 1988
ISO 286-2 - 1988

- The rod must be clean and dry to maintain optimum holding forces.
- The surface roughness Rmax should be 1.6 microns [63 micro-inch] or better.
- The rated holding force corresponds to static load conditions. If the rated value is exceeded, slippage may occur. Operating dynamic forces must not exceed the static holding force.

	CAUTION
	Nexen's Static Rod Lock is suitable for infrequent dynamic braking (emergency stops) when used with hardened shaft material. Repeated dynamic stops may cause rod and/or collar wear, reducing holding forces.

LUBRICATION

NOTE

Nexen pneumatically actuated devices require clean, pressure regulated air for maximum performance and life. All seals in Nexen pneumatically operated devices are lubricated for life, and do not require additional lubrication.

However, some customers prefer to use an air line lubricator, which injects oil into the pressurized air, forcing an oil mist into the air chamber. This is acceptable, but care must be taken to ensure once an air mist lubrication system is used, it is continually used over the life of the product as the oil mist may wash free the factory installed lubrication.

Locate the lubricator above and within ten feet of the product, and use low viscosity oil such as SAE-10.

Synthetic lubricants are not recommended.

Nexen product's bearings are shielded and pre-lubricated, and require no further lubrication.

LUBRICATOR DRIP RATE SETTINGS

	CAUTION
	These settings are for Nexen supplied lubricators. If you are not using a Nexen lubricator, calibration must follow the manufacturer's suggested procedure.

- Close and disconnect the air line from the unit.
- Turn the Lubricator Adjustment Knob counterclockwise three complete turns.
- Open the air line.
- Close the air line to the unit when a drop of oil forms in the Lubricator Sight Gage.
- Connect the air line to the unit.
- Turn the Lubricator Adjustment Knob clockwise until closed.
- Turn the Lubricator Adjustment Knob counterclockwise one-third turn.
- Open the air line to the unit.

OPTIONAL LOCKING MODE SENSOR

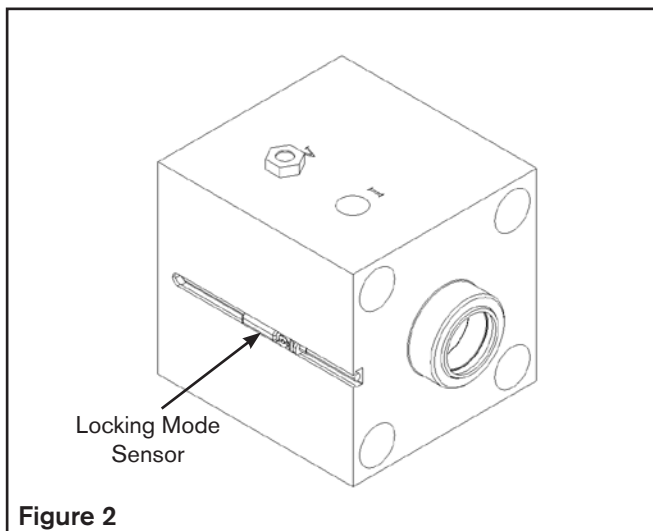

Nexen “RLSSB” products are equipped with a T-slot for an optional locking mode sensor (See Table 2). This sensor can be positioned in the T-slot to relay when the Rod Lock is disengaged or engaged on the shaft.

Once the sensor is properly located to relay when the Rod Lock is in the desired state, use a standard flat-head screwdriver or 1.5 mm allen wrench to turn the screw and fix the sensor in the T-slot (See Figure 2).

Table 2 Inductive Sensor Product Numbers

Sensor Product Number	Type
966190	NPN (Sinking)
966195	PNP (Sourcing)

AIR CONNECTIONS



! DANGER

Support the load before disengaging the Rod Lock. Failure to support the load could result in serious bodily injury.

1. The Nexen rod lock is equipped with a NPTF or BSPP port for the air inlet. Route clean air, using soft or hard lines, supplying at least 4.1 bar [60 psi] to facilitate full disengagement.

NOTE: Install the valve in close proximity to the Rod Lock unit for faster engagement and disengagement.

Higher air pressures will also speed the disengagement time, but do not exceed 8.0 bar [120 psi] air pressure.

2. The Nexen rod lock is equipped with a port for the internal vent (filters are included with most models). If the air quality around the application is poor, route the vent of the rod lock to a more suitable area, or use a filtered breather. Contact Nexen for available components.

NOTE: Clean air is important for proper Rod Lock functioning. Debris inside the Rod Lock may inhibit performance and/or shorten the life of the product.

All Nexen pneumatically actuated devices require clean and dry air, which meet or exceeds ISO 8573.1:2001 Class 4.4.3 quality.

NOTE

For quick response, Nexen recommends a quick exhaust valve and short air lines between the Control Valves and the unit. Align the air inlet ports to a down position to allow condensation to drain out of the air chambers of the product.

AIR CONTROLS AND PROGRAMMING

CYLINDER MOUNTING

Minimum release pressure = 4 bar [60 psi]
 Maximum pressure = 8 bar [120 psi]

Cylinder functioning is regulated by a 5/3 valve (use cylinder manufacturer's recommend Cv valves), center open on the central port and supplied by exhaust ports.

NOTE: Do not use a valve with a closed center. This will cause unbalance in the piston if any of the circuits leak.

One-directional flow reducers can be used to control the speed of the cylinder rod. To ensure fast braking of the rod, a quick exhaust valve can be installed on or near the rod lock.

The normally closed (NC) solenoid valve directs the air supply to the rod lock, keeping it disengaged until the electrical signal is interrupted.

Vertical Mounting: The force on the piston must not exceed its locking capacity when it is combined with the force of the load.

Use of a 5/3 valve provides a braking effect and maintains accurate rod positioning. Stopping precision is determined by the rate of speed of the rod and loads in motion.

Horizontal Mounting: Pressure is maintained on both sides of the cylinder piston, keeping it balance, preventing displacement of the rod upon release. Use exhaust ports 3 and 5 (see below).

STAND-ALONE MOUNTING

Specifications match those of cylinder models listed above.

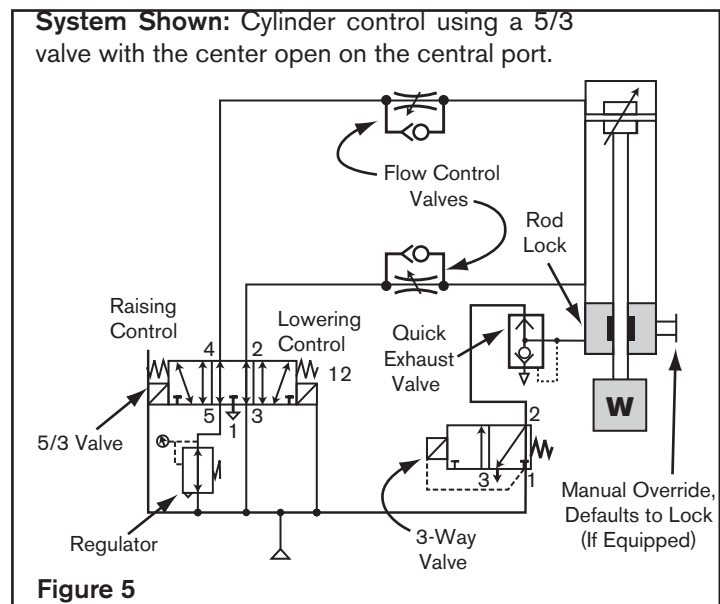
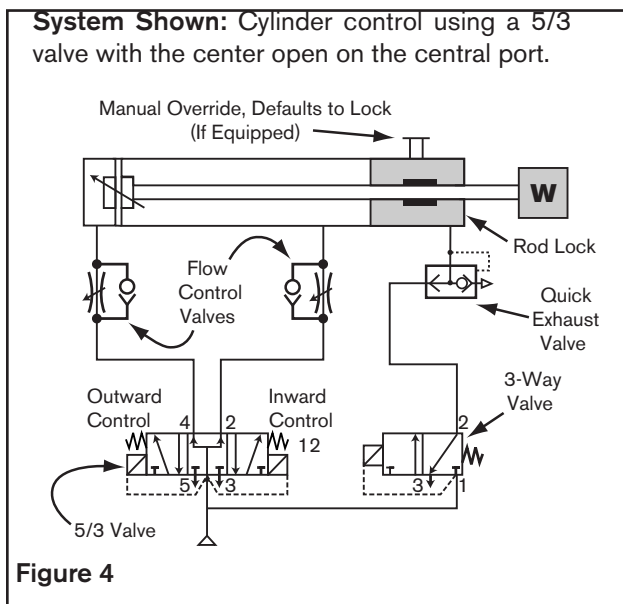

⚠ CAUTION

When programming the Nexen Rod Lock in motion control systems, it is critical to avoid repeated overlapping conditions (i.e.: forced motion during the engagement or disengagement of the Rod Lock). Shaft damage will result. Design the control system to use the Rod Lock in static conditions.

Nexen's Rod Lock must mount to a shaft hardened to a minimum of HRC60 or hard-chrome plated to a minimum thickness of 20 microns [0.0008 in] or damage to the shaft may result.

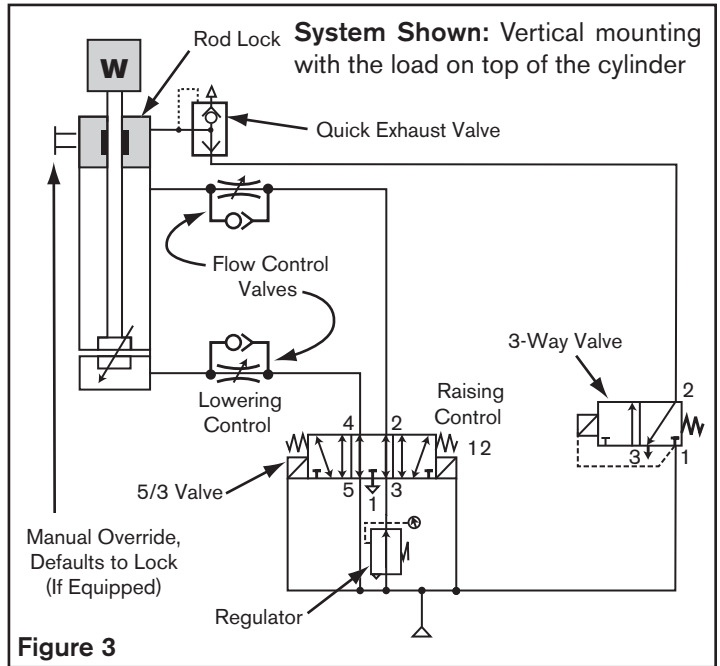

MANUAL RELEASE

The Nexen RLSS-C-MR and the RLSS-S-MR are designed with a manual release (override). In the event that the air supply is cut off or unavailable, unlocking can be performed with a common wrench or socket. Simply turn the bolt clockwise and hold to release the Rod Lock (See Figure 6).

The cam is designed to be fail-safe and will not allow the Rod Lock to unlock without applying torque. If torque to the bolt is relieved, the mechanism will re-lock.

	<p>CAUTION</p> <p>The release of mechanism is designed to turn only in the clockwise direction, as shown by the arrows on the product. Do not turn the bolt counterclockwise; damage to the release mechanism may result.</p>
---	--

	<p>CAUTION</p> <p>Do not over-torque release mechanism. Using excessive torque may damage mechanism.</p>
---	---

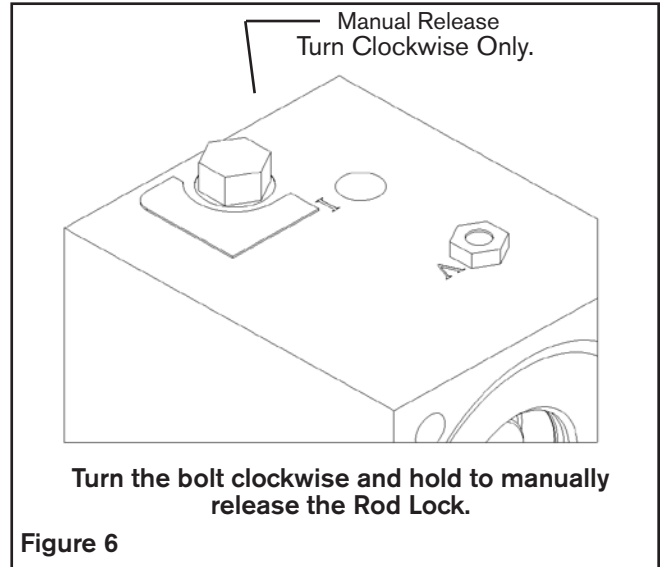

SERVICE RECOMMENDATION

NOTE: The rod lock assembly is designed for extended service life. Due to this long product life, stored spring energy, and the complexity of the internal components, Nexen recommends that all service be performed by trained personnel.

Do not attempt to remove the retaining ring and dismantle the rod lock assembly. This product is spring loaded and under pressure. If the product malfunctions, replace the unit or contact Nexen.

WARRANTY

Warranties

Nexen warrants that the Products will (a) be free from any defects in material or workmanship for a period of 12 months from the date of shipment, and (b) will meet and perform in accordance with the specifications in any engineering drawing specifically for the Product that is in Nexen's current product catalogue, or that is accessible at the Nexen website, or that is attached to this Quotation and that specifically refers to this Quotation by its number, subject in all cases to any limitations and exclusions set out in the drawing. NEXEN MAKES NO OTHER WARRANTY, EXPRESS OR IMPLIED, AND ALL IMPLIED WARRANTIES, INCLUDING WITHOUT LIMITATION, IMPLIED WARRANTIES OF MERCHANTABILITY AND FITNESS FOR A PARTICULAR PURPOSE ARE HEREBY DISCLAIMED. This warranty applies only if: (a) the Product has been installed, used and maintained in accordance with any applicable Nexen installation or maintenance manual for the Product; (b) the alleged defect is not attributable to normal wear and tear; (c) the Product has not been altered, misused or used for purposes other than those for which it was intended; and (d) Buyer has given written notice of the alleged defect to Nexen, and delivered the allegedly defective Product to Nexen, within one year of the date of shipment.

Exclusive Remedy

The exclusive remedy for the Buyer for any breach of any warranties provided in connection with this agreement will be, at the election of Nexen: (a) repair or replacement with new, serviceably used, or reconditioned parts or products; or (b) issuance of credit in the amount of the purchase price paid to Nexen by the Buyer for the Products.

Agent's Authority

Buyer agrees that no agent, employee or representative of Nexen has authority to bind Nexen to any affirmation, representation, or warranty concerning the Products other than those warranties expressly set forth herein.

Limitation on Nexen's Liability

TO THE EXTENT PERMITTED BY LAW NEXEN SHALL HAVE NO LIABILITY TO BUYER OR ANY OTHER PERSON FOR INCIDENTAL DAMAGES, SPECIAL DAMAGES, CONSEQUENTIAL DAMAGES OR OTHER DAMAGES OF ANY KIND OR NATURE WHATSOEVER, WHETHER ARISING OUT OF BREACH OF WARRANTY OR OTHER BREACH OF CONTRACT, NEGLIGENCE OR OTHER TORT, OR OTHERWISE, EVEN IF NEXEN SHALL HAVE BEEN ADVISED OF THE POSSIBILITY OR LIKELIHOOD OF SUCH POTENTIAL LOSS OR DAMAGE. For all of the purposes hereof, the term "consequential damages" shall include lost profits, penalties, delay damages, liquidated damages or other damages and liabilities which Buyer shall be obligated to pay or which Buyer may incur based upon, related to or arising out of its contracts with its customers or other third parties. In no event shall Nexen be liable for any amount of damages in excess of amounts paid by Buyer for Products or services as to which a breach of contract has been determined to exist. The parties expressly agree that the price for the Products and the services was determined in consideration of the limitation on damages set forth herein and such limitation has been specifically bargained for and constitutes an agreed allocation of risk which shall survive the determination of any court of competent jurisdiction that any remedy herein fails of its essential purpose.

Inspection

Buyer shall inspect all shipments of Products upon arrival and shall notify Nexen in writing, of any shortages or other failures to conform to these terms and conditions which are reasonably discoverable upon arrival without opening any carton or box in which the Products are contained. Such notice shall be sent within 14 days following arrival. All notifications shall be accompanied by packing slips, inspection reports and other documents necessary to support Buyer's claims. In addition to the foregoing obligations, in the event that Buyer receives Products that Buyer did not order, Buyer shall return the erroneously shipped Products to Nexen within thirty (30) days of the date of the invoice for such Products; Nexen will pay reasonable freight charges for the timely return of the erroneously shipped Products, and issue a credit to Buyer for the returned Products at the price Buyer paid for them, including any shipping expenses that Nexen charged Buyer. All shortages, overages and nonconformities not reported to Nexen as required by this section will be deemed waived.

Limitation on Actions

No action, regardless of form, arising out of any transaction to which these terms and conditions are applicable may be brought by the Buyer more than one year after the cause of action has accrued.

nexen

Nexen Group, Inc.
560 Oak Grove Parkway
Vadnais Heights, MN 55127

800.843.7445
Fax: 651.286.1099
www.nexengroup.com

ISO 9001 Certified

