

PRECISION MOTION CONTROL

Application & Selection Guide

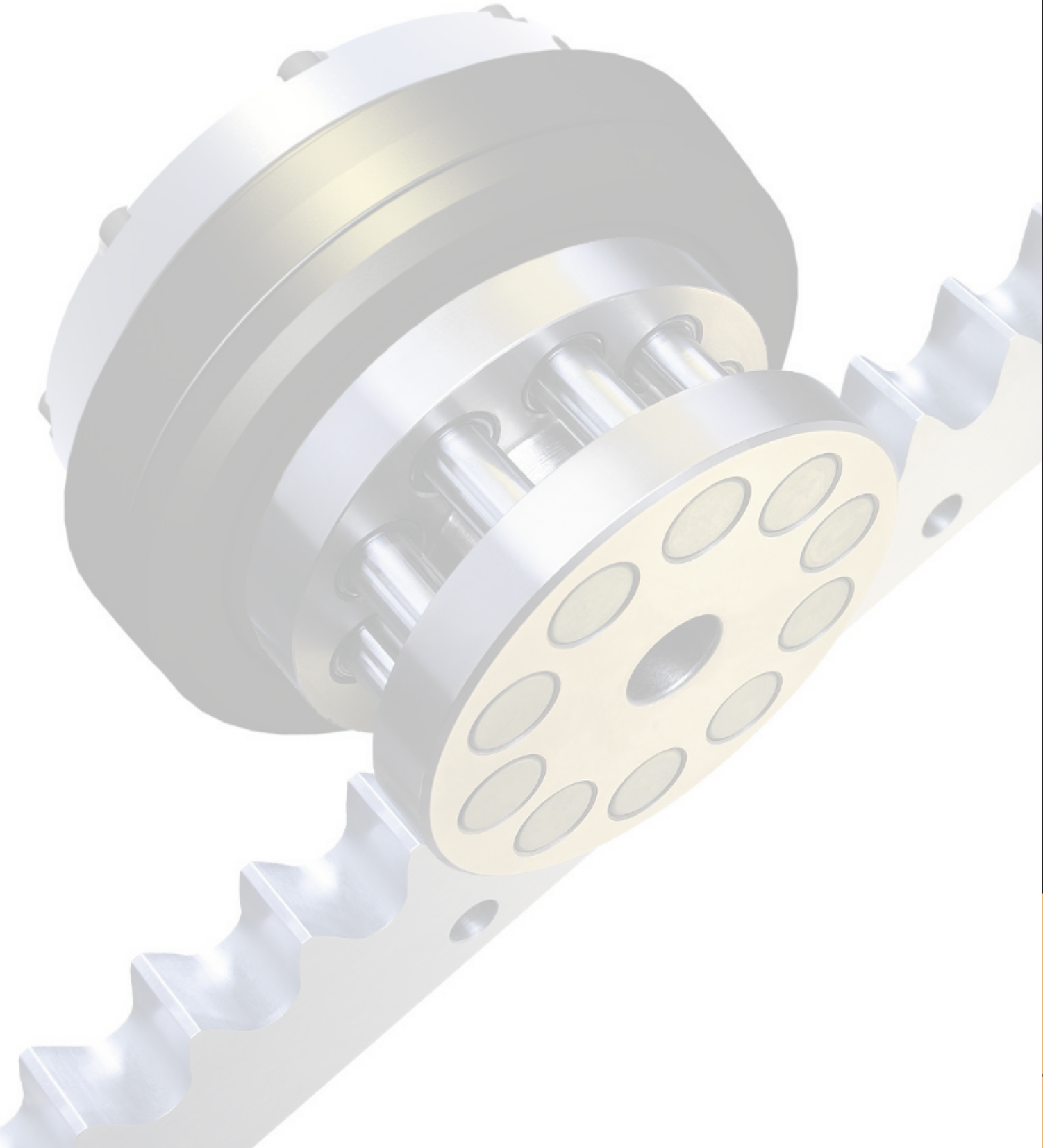

The most advanced technology in linear and rotary motion control.



A New Standard For Precision

The Nexen Roller Pinion System (RPS) revolutionizes linear and rotary motion control possibilities. Giving a fresh face to traditional rack and pinion systems, the RPS overcomes the troublesome limitations of conventional drive systems and offers unmatched performance. Across industries as varied as laser cutting and mining, users will benefit from the accuracy and 99% efficiency of this new technology.

The incredible performance of the RPS starts with a pinion consisting of bearing-supported rollers that engage a unique tooth profile. Two or more rollers engage the teeth in opposition at all times to eliminate backlash. The pinion rollers glide easily along a tangent path and roll smoothly down the tooth face for quiet, low-friction operation.

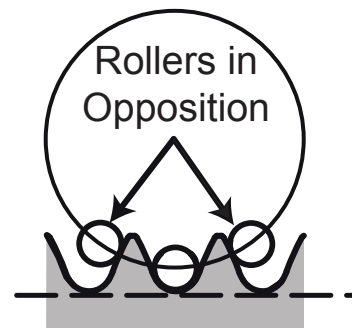

Constant Positional Accuracy Regardless of the Distance Traveled

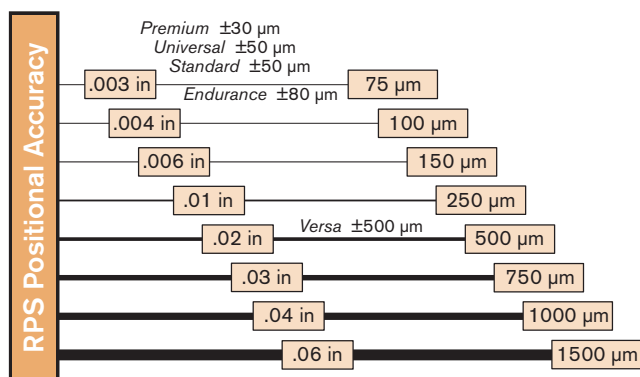

Every aspect of the RPS system is designed for reliable, easy operation. With customizations available to meet the specific needs of any application and multiple material finishes, the RPS system can go anywhere. Even installation is worry-free with a simple alignment tool to ensure positional accuracy over multiple sections of rack.

Dependable Performance. Every Time.
The Nexen RPS System Always Delivers.

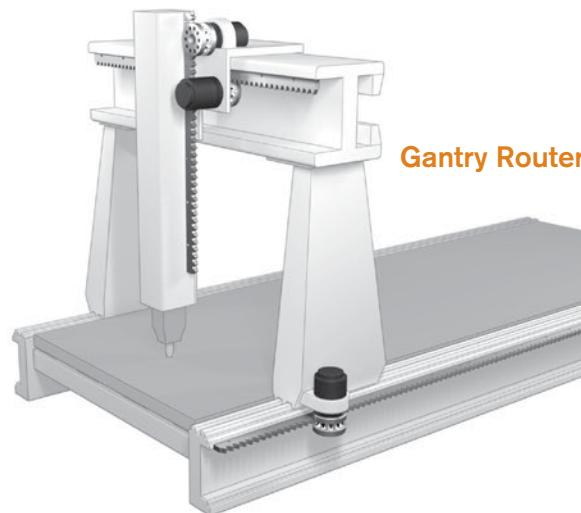
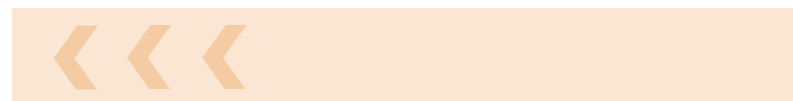
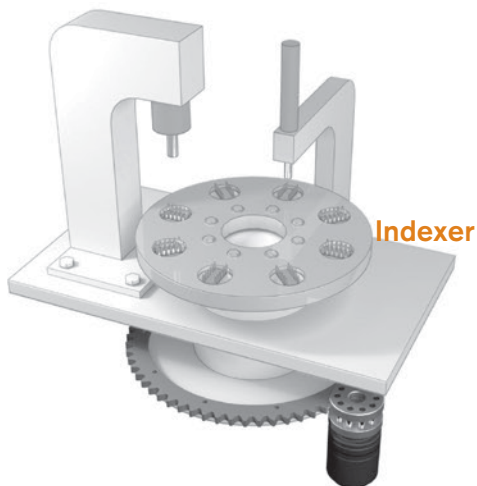

S.I.T., S.A. | Tfn. 943 457200 | Fax 943 463356 | www.sitsa.es | atencioncliente@sitsa.es

THE NEXEN ADVANTAGE

Overcoming Common Problems Found in Traditional Drive Systems

INDUSTRY PROBLEMS	Ball Screws	Traditional Rack/Gear & Pinion Systems	Belt Drives	Chain Drives	Linear Motors Direct Rotary Stages Direct Drive Motors	nexen ROLLER PINION SYSTEMS
Low Accuracy			☐	☐		High Positional Accuracy
Backlash / Vibrations	☐	☐	☐	☐		Near-Zero Backlash
High Cost	☐	☐			☐	Economical, Efficient Components
Dirty Operation	☐	☐	☐	☐		No Dust Emissions
High Maintenance	☐	☐		☐	☐	Little to No Maintenance
Low Load Capacity			☐		☐	High Load Capacity
Noisy	☐	☐	☐	☐		Quiet: pinion rollers glide smoothly along teeth
Low Speed	☐	☐				High Speeds (up to 11 m/sec)
Magnetic Field					☐	No magnetic field
High Wear/ Low Life	☐	☐	☐	☐		Long Life (up to 36 million meters)
Limited System Length/Size	☐		☐	☐		Custom Rack Sizes & Modular Components

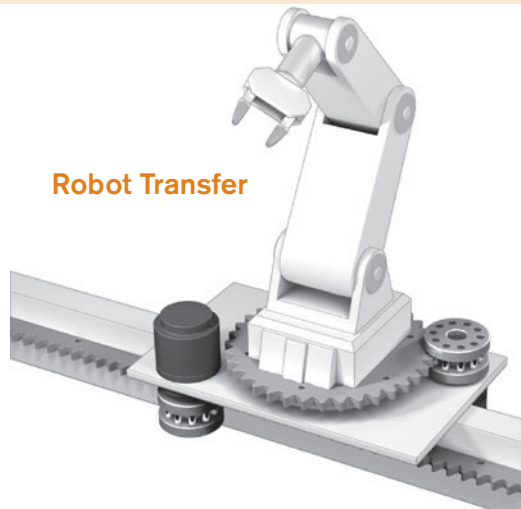

EVEN
In The Most Challenging
APPLICATIONS



S.I.T., S.A. | Tfno. 943 457200 | Fax 943 463356 | www.sitsa.es | atencioncliente@sitsa.es

Medical Imaging • Measurement Systems • Clean Rooms • Material Handling • Vacuum Environments • Welding



S.I.T., S.A. | Tfno. 943 457200 | Fax 943 463356 | www.sitsa.es | atencioncliente@sitsa.es

RPS SYSTEM

Nexen offers both premium and value roller pinions with rack options to fit any application. The following tables show specifications for the various rack and pinion configurations.

Rack & Pinion Model Comparisons	6
Rack Thrust Capacity	7
Pinion Torque	7
Accuracy & Repeatability	7
Rack Model Attributes	7

RPS System Configurations & Comparisons

Nexen features six different rack models and two pinion types, ensuring the perfect solution for any application. First compare the rack attributes to determine which rack model best meets your needs. Then compare the specifications of both the premium and value pinions to select the ideal RPS system configuration.

Rack Models Available

PREMIUM RACK	<p>As the name premium suggests, this is Nexen's top of the line model featuring market leading accuracy and a hard chrome coating for corrosion resistance. A perfect choice for any precision motion need.</p> <ul style="list-style-type: none"> • Very High Precision/Accuracy • Suitable for Dirty Environments • Lubrication Free • High Load Capacity • High Corrosion Resistance <p><i>Precision Assembly Equipment • Machine Tool/CNC Mills • High Precision Gantry • Robotics</i></p>
STANDARD RACK	<p>The Standard Rack offers similar performance to the Premium model without the corrosion resistant coating. With slightly lower accuracy, the standard model still delivers dependable performance in many the same types of applications. A great, cost-saving choice when corrosion resistance is not required.</p> <ul style="list-style-type: none"> • High Precision/Accuracy • High Load Capacity • No Corrosion Resistance • Lower Cost than Premium Rack <p><i>Precision Assembly Equipment • Machine Tool/CNC Mills • High Precision Gantry • Robotics</i></p>
ENDURANCE RACK	<p>This is the work horse of the product line, combining both high load capacity and good corrosion resistance.</p> <ul style="list-style-type: none"> • High Load Capacity • Medium Corrosion Resistance • Good Accuracy (not high precision) <p><i>General Assembly Equipment • Machine Tool • Gantry Systems</i></p>
UNIVERSAL RACK	<p>With better accuracy than Endurance Racks, the Universal Rack is a great option for lower load applications when corrosion resistance is not required.</p> <ul style="list-style-type: none"> • High Accuracy • Medium Load Capacity • No Corrosion Resistance <p><i>Material Handling Equipment • Gantry Systems • Packaging Equipment • General Motion Control</i></p>
UNIVERSAL STAINLESS RACK	<p>Get all the features of the Universal Rack with the added benefits of corrosion resistant stainless steel.</p> <ul style="list-style-type: none"> • High Accuracy • Medium Load Capacity • Wet or Dirty Environments • Very High Corrosion Resistance <p><i>Material Handling Equipment • Gantry Systems • Packaging Equipment • General Motion Control</i></p>
VERSA RACK	<p>Made from thermoplastic, this rack can go places no other racks can go. It's wide range of applications make it a great fit for general motion control applications looking for the advantages of the RPS in a conventional accuracy version.</p> <ul style="list-style-type: none"> • Extremely High Corrosion Resistance • Light Load Motion Control • High Durability • Basic Actuator (similar to cylinder/belt) <p><i>Equipment with Conventional Accuracy Requirements • Packaging • General Motion Control</i></p>

Pinion Models Available

PREMIUM PINION	<p>This long time standard at Nexen offers the best precision on the market. Use with any RPS rack for unbeatable performance.</p> <ul style="list-style-type: none"> • Very High Precision/Accuracy • High Torque Capacity • Great Performance in Any Application
VALUE PINION	<p>A great fit for unique applications, Nexen offers the Value pinion to fit applications looking for the general features of Nexen's RPS in a conventional accuracy version.</p> <ul style="list-style-type: none"> • Lighter Load, General Accuracy Applications • Harsh Environments • Available in Sizes 16, 20 & 25

RPS System Specifications

Table 1 Rack Thrust Capacity (N)

RPS Size	Premium Rack			Standard Rack			Endurance Rack			Universal & Universal Stainless Racks			Versa Rack			
	Accel.	Avg.	Static	Accel.	Avg.	Static	Accel.	Avg.	Static	Accel.	Avg.	Static	Accel.	Avg.	Static	
PREMIUM PINION	10	250	250	380	NA	NA	NA	NA	NA	NA	NA	NA	NA	NA	NA	
	12	500	500	750	NA	NA	NA	NA	NA	NA	NA	NA	NA	NA	NA	
	16	2400	1000	2400	2400	1000	2400	1500	1000	2000	750	750	750	500	500	500
	20	2900	1500	3000	2900	1500	3000	2250	1500	3000	1125	1125	1125	750	750	750
	25	4000	2200	4400	4000	2200	4400	3300	2200	4400	1650	1650	1650	1100	1100	1100
	32	6300	3600	7200	6300	3600	7200	5400	3600	7200	2700	2700	2700	NA	NA	NA
	40	6000	6000	12000	6000	6000	12000	6000	6000	12000	4500	4500	4500	NA	NA	NA
4014	14000	14000	21000	14000	14000	21000	14000	14000	21000	10500	10500	10500	NA	NA	NA	
VALUE PINION	16	500														
	20	750														
	25	1100														

Table 2 Pinion Torque (Nm)

RPS Size	Peak Pinion Torque		Maximum Average Pinion Torque for Full Life	
	Premium Pinion	Value Pinion	Premium Pinion	Value Pinion
10	4.0	NA	4.0	NA
12	9.5	NA	9.5	NA
16	61.1	12.8	33.7	12.8
20	92.3	23.9	52.5	23.9
25	159.2	43.8	89.5	43.8
32	385.0	NA	218.7	NA
40	458.4	NA	458.4	NA
4014	1247.8	NA	1247.8	NA

Table 3 Accuracy & Repeatability

PINION TYPE	RACK MODEL		Premium Rack	Standard Rack	Endurance Rack	Universal Rack & Universal Stainless	Versa Rack
Premium Pinion	Accuracy	± μm	30	50	80	50	500
	Repeatability	± μm	5	10	20	10	20
Value Pinion	Accuracy *	± μm	110	130	160	130	580
	Repeatability *	± μm	5	10	20	10	20

Table 4 Rack Model Attributes (NOT AFFECTED BY PINION CHOICE)

ATTRIBUTES	RACK MODEL	Premium Rack	Standard Rack	Endurance Rack	Universal Rack	Universal Stainless	Versa Rack
Backlash*	μm	0					
Corrosion Resistant Surface Treatment		Hard Chrome	None	Nitrided	None	None	Plastic
Corrosion Resistance Rating		High	None	Medium	None	Very High	Extremely High
Lubrication Free Operation		Yes up to 30 m/min	No	Yes up to 30 m/min	No	No	Yes up to max speed
Noise Level	dB	up to 75 (Speed Dependent)					
Temperature Range	°C	-5 to 40					

* Specifications listed for the Value Pinion are "out-of-box" ratings. Over time, these specifications are affected by operating torque and speed.

NOTE: Refer to the **System Life** section for Load Life Comparison. See the **Definitions** section at the end of this catalog for details on these attributes.



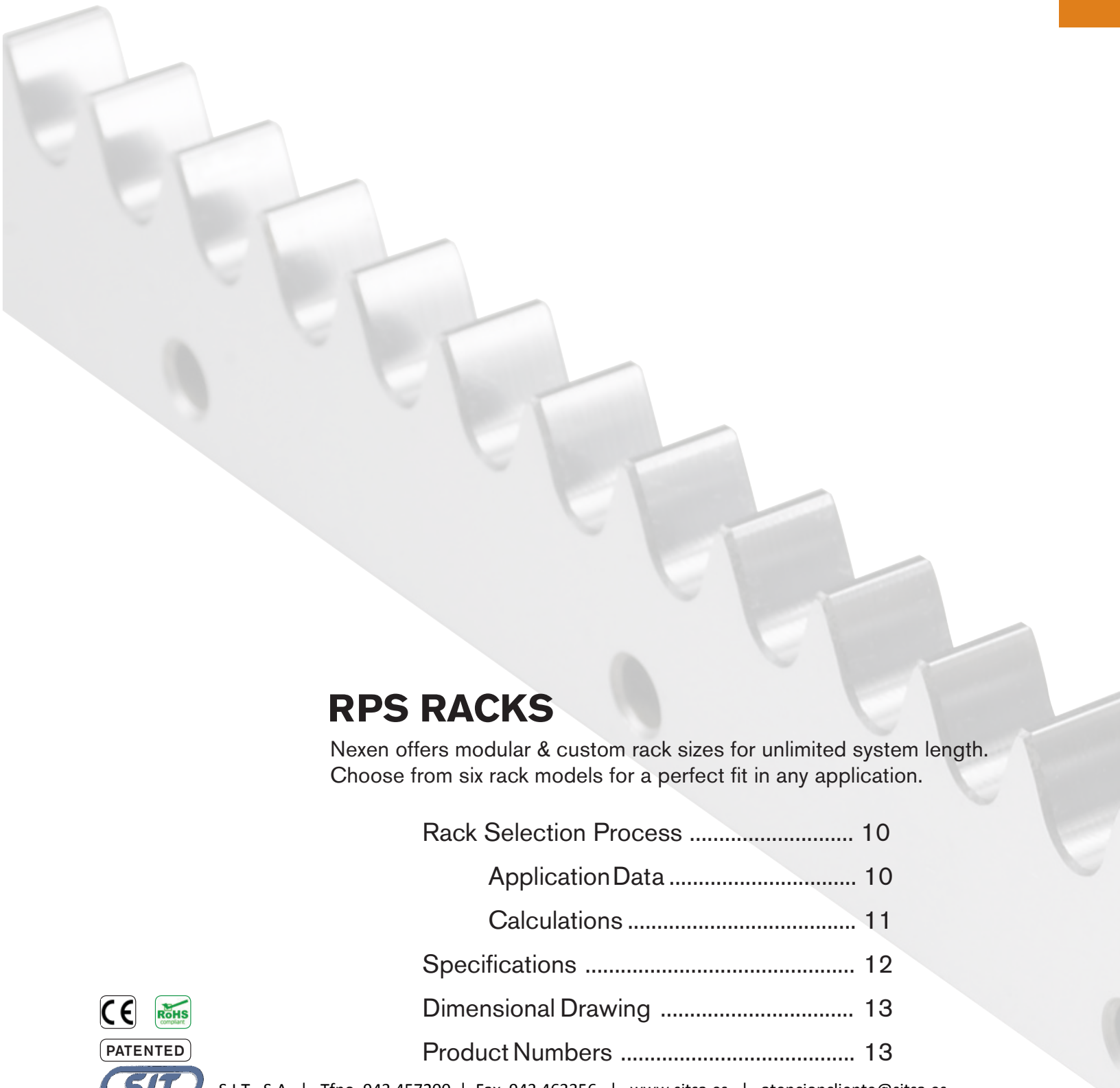

RPS RACKS

Nexen offers modular & custom rack sizes for unlimited system length. Choose from six rack models for a perfect fit in any application.

Rack Selection Process	10
Application Data	10
Calculations	11
Specifications	12
Dimensional Drawing	13
Product Numbers	13



PATENTED



Linear Rack Selection Process

Nexen offers a large range of rack sizes and materials, so you can find the perfect components for your application. Take advantage of the following guide designed to make selecting the right components for your system simple. If you don't find what you need, contact Nexen Group.

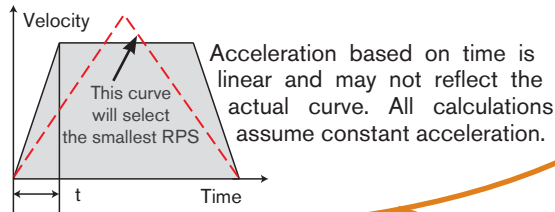
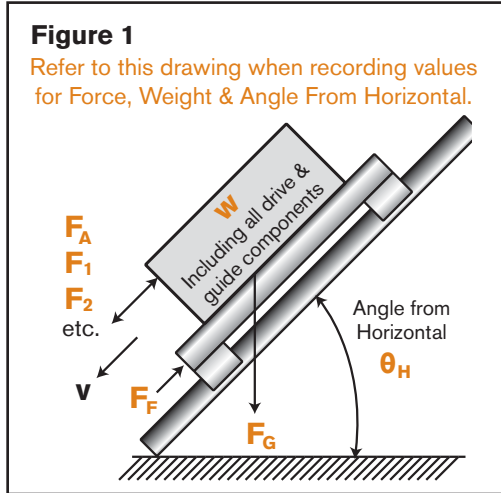

Weight to be Driven should include all drive and guide components and structures being moved and should reflect the maximum weight each individual pinion must bear at any given time. Take into account any movable or asymmetric loads that may shift between multiple pinions during operation.

STEP 1: GATHER APPLICATION DATA

Before you begin calculations, there are nine key measurements that you will need from your application. Collect the data and record it in the chart below. With this data available you can proceed on to the calculations on the following page.

Measurements Required for RPS Selection	Customer Data (record your values below)	Sample Data
Angle from Horizontal (θ_H) Refer to Figure 1.	°	60°
Maximum Velocity (V_{max})	m/s	0.5 m/s
Travel Distance (L) (single direction move)	m	5.4 m
Cycles Per Day (N_{day}) (assumes single direction move)		1000
Acceleration Time (t_A) or Known Acceleration	seconds m/s ²	0.5 s
Weight to be Driven (W)	kgf	150.0 kgf
Other Forces (F_1 , F_2) etc.	N	0 N
Shock Factor (K) Circle the value that best reflects the smoothness of your application.	Shockless Operation 1.0 Normal Operation 1.2 Operation with Impact 1.5 Operation with High Impact 2.5	1.2
Frictional Coefficient (μ) Circle the value that best reflects your application.	Profile Guide Rail 0.005 Ball Bearing Guide Rail 0.02 Polymer Bushing Guide 0.1 Bronze Bushing Guide 0.2	0.01

Other Key Application Information

Application Description:

Environmental Conditions: Typical Industrial High Humidity High Temperature High Dust

Positional Accuracy Requirements:

STEP 2: CALCULATING RPS REQUIREMENTS

Rack selection is based on the load capacity required by your application. Using the information gathered on the preceding page, perform the following calculations to determine the Total Force of the Load. Use the space provided to record your calculations. (The sample calculations assume a single pinion driving an axis. Use the Sample Data from the chart on the preceding page.)

LOAD MASS: $M = W$ Use the total Weight to be Driven as your Load Mass value. <i>Sample: $M = 150.0 \text{ kgf} = 150 \text{ kg}$</i>		LOAD MASS $M =$ <input type="text"/> kg
LOAD ACCELERATION: $A = V_{\max} \div t_A$ A known acceleration from a servo drive provider is preferred if available. <i>Sample: $A = 0.5 \text{ m/s} \div 0.5 \text{ s} = 1.0 \text{ m/s}^2$</i>		LOAD ACCELERATION $A =$ <input type="text"/> m/s \div <input type="text"/> s $A =$ <input type="text"/> m/s ²
FORCE DUE TO LOAD ACCELERATION: $F_A = M \cdot A$ <i>Sample: $F_A = 150 \text{ kg} \cdot 1.0 \text{ m/s}^2 = 150.0 \text{ N}$</i>		FORCE DUE TO LOAD ACCELERATION $F_A =$ <input type="text"/> kg \cdot <input type="text"/> m/s ² $F_A =$ <input type="text"/> N
FORCE DUE TO GRAVITY: $F_G = M \cdot g \cdot \sin(\theta_H)$ <i>Sample: $F_G = 150 \text{ kg} \cdot 9.81 \text{ m/s}^2 \cdot \sin(60^\circ) = 1274.4 \text{ N}$</i>		FORCE DUE TO GRAVITY $F_G =$ <input type="text"/> kg \cdot 9.81 m/s ² \cdot sin(<input type="text"/>) $F_G =$ <input type="text"/> N
FORCE DUE TO FRICTION: $F_F = M \cdot \mu \cdot g \cdot \cos(\theta_H)$ <i>Sample: $F_F = 150 \text{ kg} \cdot 0.01 \cdot 9.81 \text{ m/s}^2 \cdot \cos(60^\circ) = 7.4 \text{ N}$</i>		FORCE DUE TO FRICTION $F_F =$ <input type="text"/> kg \cdot <input type="text"/> \cdot 9.81 m/s ² \cdot cos(<input type="text"/>) $F_F =$ <input type="text"/> N
SUM OF FORCES: $F_S = F_A + F_G + F_F + F_1 + F_2 + \dots \text{etc}$ <i>Sample: $F_S = 150.0 \text{ N} + 1274.4 \text{ N} + 7.4 \text{ N} = 1431.8 \text{ N}$</i>		SUM OF FORCES $F_S =$ <input type="text"/> N + <input type="text"/> N + <input type="text"/> N + <input type="text"/> N + <input type="text"/> N $F_S =$ <input type="text"/> N
TOTAL FORCE WITH SHOCK FACTOR: $F_T = F_S \cdot K$ <i>Sample: $F_T = 1431.8 \text{ N} \cdot 1.2 = 1718.2 \text{ N}$</i>		TOTAL FORCE WITH SHOCK FACTOR $F_T =$ <input type="text"/> N \cdot <input type="text"/> $F_T =$ <input type="text"/> N

STEP 3: SELECTING A RACK MODEL

Use Table 4 in the RPS System section to review the six different rack models and determine the model best suited for your application.

RACK MODEL
<input type="text"/>

STEP 4: SELECTING RACK SIZE

Locate your chosen rack model in Table 1 in the RPS System section and determine the rack size with enough thrust capacity to handle the Total Force with Shock Factor calculated above for your application.

RACK SIZE
<input type="text"/>

STEP 5: EVALUATE LIFE AND VERIFY YOUR SYSTEM SPECIFICATIONS

With the rack model and size selections, evaluate expected life in the System Life section and review the Common Rack Specifications (Table 5 in the Rack Section) to be sure that the rack you have selected will meet all of your application requirements.

RACK PRODUCT NUMBER
<input type="text"/>

Rack Specifications

Table 5 Common Rack Specifications

Attribute		Rack Size	RPS10	RPS12	RPS16		RPS20		RPS25		RPS32		RPS40		RPS4014	
Max Pressure Angle		°	26.4	26.4	27.9		26.4		26.4		26.0		26.0		26.0	
Avg Pressure Angle		°	21.9	21.9	23.4		21.9		21.9		22.7		21.3		20.9	
Module		mm	3.0	3.6	4.8		6.0		7.5		9.5		12.0		12.0	
Max Speed *	All Metal Racks	m/s	4	8	4		5		8		11		6		6	
	Versa Rack	m/s	NA	NA	2		2		2		NA		NA		NA	
Rack Tooth Pitch		mm	10	12	16		20		25		32		40		40	
Rack Height		mm	27	27	30.5		42.0		48.0		57.0		72.6		69.0	
Rack Width		mm	5.7	5.7	11.5		15.5		18.5		24.5		31.5		42.0	
Rack Section Size			Half	Half	Half	Full	Half	Full	Half	Full	Half	Full	Half	Full	Half	Full
Rack Length		mm	480	480	512	992	500	1000	500	1000	512	992	520	1000	520	1000
Number of Rack Teeth			48	40	32	62	25	50	20	40	16	31	13	25	13	25
Rack Weight	All Metal Racks	kg	0.5	0.6	1.1	2.1	2.1	4.1	2.7	5.4	4.2	8.2	6.9	13.2	8.8	17.0
	Versa Rack	kg	NA	NA	0.2	0.4	0.4	0.8	0.5	1.0	NA		NA		NA	

* The maximum rated speed of a RPS system is equal to the lowest rating of either the pinion or the rack.

Rack Dimensions

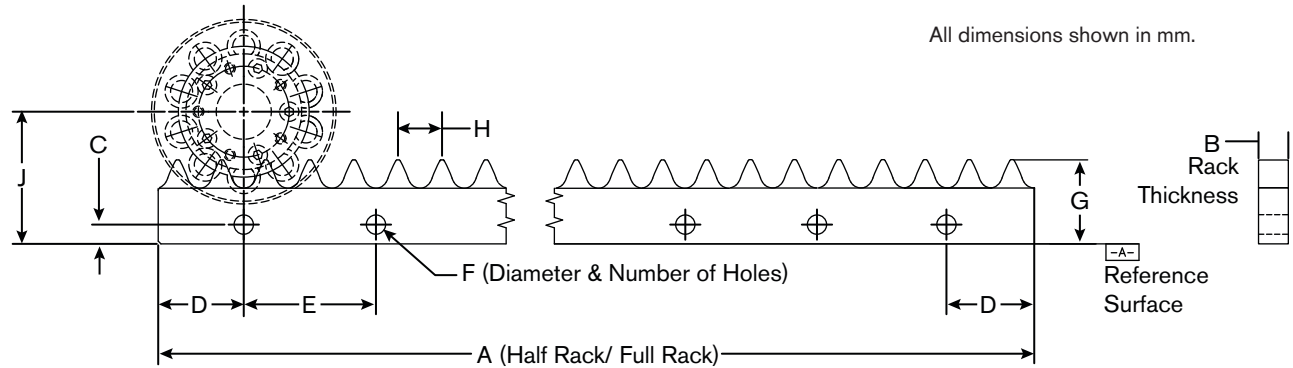

RPS Size	A		B	C	D	E	F			G	H	J
	Rack Length		Rack Thickness	Hole Height	Hole From End	Hole Spacing	Mounting Holes			Rack Height	Tooth Pitch	Axis to Base
	Half	Full					Ø	# Half Rack	# Full Rack			
RPS10	480	NA	5.7	7	29.8	60	5.5	8	NA	27.0	10	37.5
RPS12	480	NA	5.7	7	29.8	60	5.5	8	NA	27.0	12	40
RPS16	512	992	11.5	7	16	96	7	6	11	30.5	16	48
RPS20	500	1000	15.5	10	50	100	9	5	10	42.0	20	64
RPS25	500	1000	18.5	12	50	100	11	5	10	48.0	25	75
RPS32	512	992	24.5	14	16	96	14	6	11	57.0	32	102
RPS40	520	1000	31.5	16	80	120	18	4	8	72.6	40	129
RPS4014	520	1000	42.0	16	60	80	18	6	12	69.0	40	140

See drawings or CAD models on Nexen's website for additional dimensions and tolerances.

Rack Product Numbers

RPS Size	Rack Length		Premium	Standard	Endurance	Universal	Universal Uncoated Stainless	Universal Coated Stainless	Versa
10	Half	480 mm	966768	NA	NA	NA	Contact Nexen	Contact Nexen	NA
	Alignment Tool		966507						
12	Half	480 mm	966769	NA	NA	NA	Contact Nexen	Contact Nexen	NA
	Alignment Tool		966508						
16	Half	512 mm	966652	966602	Contact Nexen	966801	966760	966742	Contact Nexen
	Full	992 mm	966651	966601	966850	966800	966813	966741	966860
	Alignment Tool		966503						
20	Half	500 mm	966662	966612	Contact Nexen	966803	Contact Nexen	Contact Nexen	Contact Nexen
	Full	1000 mm	966661	966611	966851	966802	966625	966619	966861
	Alignment Tool		966513						
25	Half	500 mm	966672	966622	Contact Nexen	966805	Contact Nexen	Contact Nexen	Contact Nexen
	Full	1000 mm	966671	966621	966852	966804	966814	966755	966862
	Alignment Tool		966523						
32	Half	512 mm	966682	966632	Contact Nexen	966807	Contact Nexen	Contact Nexen	NA
	Full	992 mm	966681	966631	966853	966806	966812	Contact Nexen	NA
	Alignment Tool		966533						
40	Half	520 mm	966692	966642	Contact Nexen	966809	Contact Nexen	Contact Nexen	NA
	Full	1000 mm	966691	966641	966854	966808	966815	Contact Nexen	NA
	Alignment Tool		966543						
4014	Half	520 mm	966695	966647	Contact Nexen	966811	Contact Nexen	Contact Nexen	NA
	Full	1000 mm	966694	966646	966855	966810	966816	Contact Nexen	NA
	Alignment Tool		966543						
Rack Grease			853901						



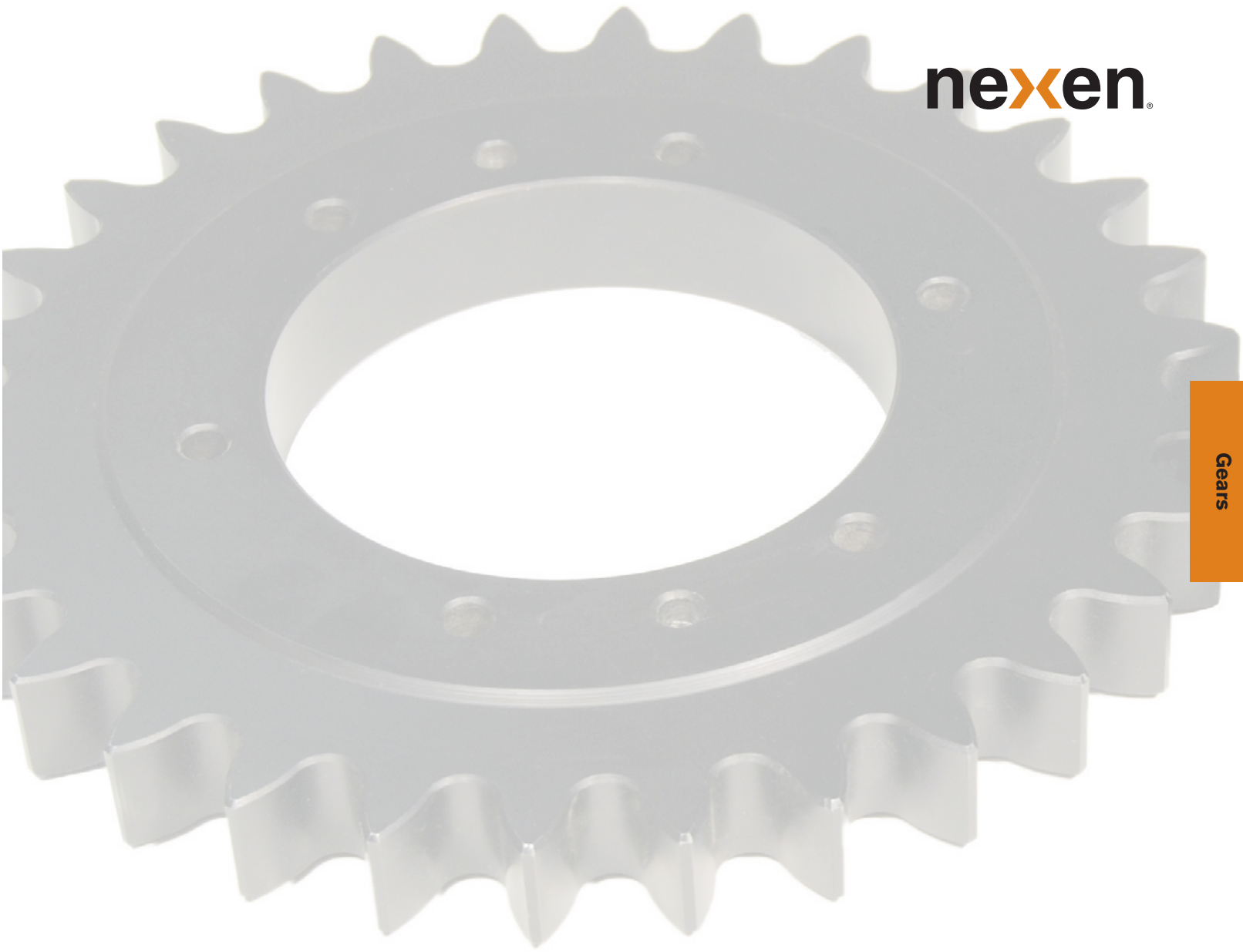

RPG GEARS

Nexen offers the RPG Gears as solid rings up to 1.7 m in diameter. Segmented rings or arcs can also be combined to create your own custom rotary drive system.

Gear Selection Process	16
Application Data	16
Calculations	17
Specifications	18
Dimensional Drawings	19
Product Numbers	19



PATENTED



Rotary Gear Selection Process

Nexen offers both gears and individual arc segments for unlimited possibilities in your machine design. Take advantage of the following guide designed to make selecting the right components for your system simple. **If you don't find what you need, contact Nexen Group about a custom design.**

STEP 1: GATHER APPLICATION DATA

Before you begin calculations, there are key measurements that you will need from your application. Collect the data and record it in the chart below. With this data available you can proceed on to the calculations on the following page.

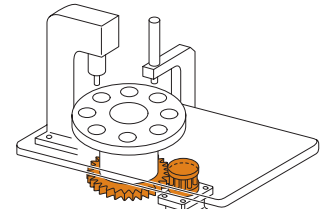

SAMPLE APPLICATION INFORMATION

- Electronics Assembly Indexing Table
- 1 meter in diameter
- 8 stations equally spaced
- 60 indexes per minute desired
- Dwell time 0.33 sec

Measurements Required for RPG Selection	Customer Data (record your values below)	Sample Data
Angle Gear Rotates Relative to Horizontal Plane (θ_H)	°	0°
Rotational Moment of Inertia (I)	kgm ²	10.0 kgm ²
Indexes Per Revolution (N_I)	IPR	8 IPR
Indexes Per Day (N_{day})		10800 RPD
Index Time (t_I) or Known Angular Acceleration (α)	seconds rad/s ²	0.66 sec
Weight to be Driven (W) Should include everything in motion.	kg	20.0 kg
Dwell Time (t_D)	seconds	0.33 sec
Maximum Allowable Ring Gear OD (D_{max})	mm	400 mm
Minimum Allowable Ring Gear ID (D_{min})	mm	200 mm
Ring Gear Tooth Orientation (Select one)	external/internal	external
Other Forces (T_1 , T_2) etc. May include gravitational forces due to imbalanced load, springs, wind, counterbalance, fluid dampening systems, etc.	Nm	0 Nm
Shock Factor (K) Circle the value that best reflects the smoothness of your application.	Shockless Operation 1.0 Normal Operation 1.2 Operation with Impact 1.5 Operation with High Impact 3.0	1.2
Frictional Coefficient (μ) Circle the value that best reflects your application.	Rolling Bearing 0.005~0.02 Sliding Bearing 0.1~0.2	0.01
Diameter of Bearing Element (D_B)	mm	50 mm

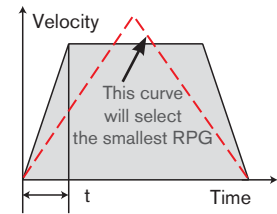

Acceleration based on time is linear and may not reflect the actual curve. All calculations assume constant acceleration.

Other Key Application Information

Application Description:

Environmental Conditions: Typical Industrial High Humidity High Temperature High Dust

Positional Accuracy Requirements:

STEP 2: CALCULATING RPG REQUIREMENTS FOR SIMPLE INDEXING APPLICATIONS

Gear selection is based on the load capacity required by your application. Using the information gathered on the preceding page, perform the following calculations. If acceleration or deceleration times vary, or there are other changes in velocity, calculate the acceleration torque for each interval and use the highest value for RPG selection purposes.

ACCELERATION TIME: $t_A = t_i \div 2$		$t_A =$ <input type="text"/> sec $\div 2$	ACCELERATION TIME $t_A =$ <input type="text"/> sec
<i>Sample: $t_A = 0.66 \text{ seconds} \div 2 = 0.33 \text{ seconds}$</i>			
ROTATION ANGLE PER INDEX: $\theta = 2\pi \div N_I$		$\theta = 2\pi \div$ <input type="text"/> IPR	ROTATION ANGLE PER INDEX $\theta =$ <input type="text"/> rad
<i>Sample: $\theta = 2\pi \div 8 \text{ IPR} = 0.785 \text{ rad}$</i>			
MAX ANGULAR SPEED: $\omega = \theta \div t_i \cdot 2$		$\omega =$ <input type="text"/> rad \div <input type="text"/> sec $\cdot 2$	MAX ANGULAR SPEED $\omega =$ <input type="text"/> rad/sec
<i>Sample: $\omega = 0.785 \text{ rad} \div 0.66 \text{ seconds} \cdot 2 = 2.380 \text{ rad/sec}$</i>			
ANGULAR ACCELERATION: $\alpha = \omega \div t_A$		$\alpha =$ <input type="text"/> rad/sec \div <input type="text"/> sec	ANGULAR ACCELERATION $\alpha =$ <input type="text"/> rad/s ²
<i>Sample: $\alpha = 2.380 \text{ rad/sec} \div 0.33 \text{ sec} = 7.212 \text{ rad/s}^2$</i>			
RING GEAR TORQUE: $T_{\text{gear}} = (I \cdot \alpha) + ((W \cdot \mu \cdot D_B) \div 2000)$		$T_{\text{gear}} =$ <input type="text"/> kgm ² \cdot <input type="text"/> rad/s ² $+$ $\left(\left(\right. \right.$ <input type="text"/> kg \cdot <input type="text"/> \cdot <input type="text"/> mm $\left. \right) \div 2000$	RING GEAR TORQUE $T_{\text{gear}} =$ <input type="text"/> Nm
<i>Sample: $T_{\text{gear}} = (10 \text{ kgm}^2 \cdot 7.212 \text{ rad/s}^2) + ((20 \text{ kg} \cdot 0.01 \cdot 50 \text{ mm}) \div 2000) = 72.125 \text{ Nm}$</i>			
RING GEAR TORQUE WITH SHOCK FACTOR: $T_T = T_{\text{gear}} \cdot K$		$T_T =$ <input type="text"/> Nm \cdot <input type="text"/>	RING GEAR TORQUE W/ SHOCK FACTOR $T_T =$ <input type="text"/> Nm
<i>Sample: $T_T = 72.125 \text{ Nm} \cdot 1.2 = 86.55 \text{ Nm}$</i>			
PINION THRUST REQUIRED AT MAX OD: $F_1 = (T_T \div D_{\text{max}}) \cdot 2000$		$F_1 =$ <input type="text"/> Nm \div <input type="text"/> mm $\cdot 2000$	PINION THRUST REQUIRED AT MAX OD $F_1 =$ <input type="text"/> N
<i>Sample: $F_1 = (86.55 \text{ Nm} \div 400 \text{ mm}) \cdot 2000 = 432.75 \text{ N}$</i>			
PINION THRUST REQUIRED AT MIN ID: $F_2 = (T_T \div D_{\text{min}}) \cdot 2000$		$F_2 =$ <input type="text"/> Nm \div <input type="text"/> mm $\cdot 2000$	PINION THRUST REQUIRED AT MIN ID $F_2 =$ <input type="text"/> N
<i>Sample: $F_2 = (86.55 \text{ Nm} \div 200 \text{ mm}) \cdot 2000 = 865.5 \text{ N}$</i>			

Gear Selection

STEP 3: SELECTING A GEAR SIZE

Using the table to the right, circle the RPG size needed to meet the Pinion Thrust requirements of your application (as calculated above).

RPG SIZE	10	12	16	20	25	32	40	4014	
PREMIUM PINION Dynamic Thrust (N)	@ Min Life	250	500	2400	2900	4000	6300	6000	14000
	@ Max Life	250	500	1000	1500	2200	3600	6000	14000
VALUE PINION Dynamic Thrust (N)	NA		500	750	1100	NA			

STEP 4: VERIFY YOUR SYSTEM SPECIFICATIONS

Using the selected RPG size and the Ring Gear Torque with Shock Factor requirement calculated above, use the tables on the next page to select a gear. Review Gear Specifications to ensure the selected gear meets all of your application requirements.

GEAR PRODUCT NUMBER <input type="text"/>
--



Gear Specifications

Gear Specifications

RPG Size	Gear Product Number	Gear Ratio	Pinion Type	Maximum Dynamic Torque @		Max Static Torque	Max RPM	Accuracy	Repeatability
				Minimum Life	Maximum Life				
				Nm	Nm	Nm	ArcSec	ArcSec	
16	966566	3:1	PREMIUM	183.3	101.1	183.3	500	+/- 84.2	+/- 14
			VALUE	38.1	38.1	38.1	250	+/- 308.7	+/- 14.0
	966567	4:1	PREMIUM	244.4	134.8	244.4	375	+/- 63.4	+/- 10.6
			VALUE	50.8	50.8	50.8	188	+/- 232.5	+/- 10.6
	966568	5:1	PREMIUM	305.5	168.5	305.5	300	+/- 50.9	+/- 8.5
			VALUE	63.5	63.5	63.5	150	+/- 186.5	+/- 8.5
	966569	6:1	PREMIUM	366.6	202.2	366.6	250	+/- 42.5	+/- 7.1
			VALUE	76.2	76.2	76.2	125	+/- 155.7	+/- 7.1
	966570	7:1	PREMIUM	427.7	235.9	427.7	215	+/- 36.5	+/- 6.1
			VALUE	88.9	88.9	88.9	108	+/- 134.0	+/- 6.1
	966797	15:1	PREMIUM	916.5	505.5	916.5	100	+/- 16.9	+/- 2.8
			VALUE	190.5	190.5	190.5	50	+/- 62.1	+/- 2.8
966571	40:1	PREMIUM	2444.0	1348.0	2444.0	38	+/- 6.4	+/- 1.1	
		VALUE	508.0	508.0	508.0	19	+/- 23.4	+/- 1.1	
20	966572	14:1	PREMIUM	1292.2	735.0	1337.0	108	+/- 14.4	+/- 2.4
			VALUE	334.6	334.6	334.6	43	+/- 52.6	+/- 2.4
	966798	15:1	PREMIUM	1384.5	787.5	1432.5	100	+/- 13.4	+/- 2.2
			VALUE	358.5	358.5	358.5	40	+/- 49.2	+/- 2.2
	966799	18:1	PREMIUM	1661.4	945.0	1719.0	84	+/- 11.2	+/- 1.9
			VALUE	430.2	430.2	430.2	34	+/- 41.2	+/- 1.9
	966793	54:1	PREMIUM	4984.2	2835.0	5157.0	28	+/- 3.7	+/- 0.6
			VALUE	1290.6	1290.6	1290.6	12	+/- 13.7	+/- 0.6
	966789	68.4:1	PREMIUM	6313.3	3591.0	6532.2	22	+/- 2.9	+/- 0.5
			VALUE	1634.8	1634.8	1634.8	9	+/- 10.7	+/- 0.5
	966787	90:1	PREMIUM	8307.0	4725.0	8595.0	17	+/- 2.2	+/- 0.4
			VALUE	2151.0	2151.0	2151.0	7	+/- 8.2	+/- 0.4
25	966573	3:1	PREMIUM	477.6	268.5	528.0	607	+/- 53.6	+/- 8.9
			VALUE	138.0	138.0	138.0	160	+/- 196.4	+/- 8.9
	966574	4:1	PREMIUM	636.8	358.0	704.0	455	+/- 40.1	+/- 6.7
			VALUE	184.0	184.0	184.0	120	+/- 147	+/- 6.7
	966575	5:1	PREMIUM	796.0	447.5	880.0	364	+/- 32.3	+/- 5.4
			VALUE	230.0	230.0	230.0	96	+/- 118.4	+/- 5.4
	966576	6:1	PREMIUM	955.2	537.0	1056.0	304	+/- 26.9	+/- 4.5
			VALUE	276.0	276.0	276.0	80	+/- 98.8	+/- 4.5
	966577	7.5:1	PREMIUM	1194.0	671.3	1320.0	243	+/- 21.5	+/- 3.6
			VALUE	345.0	345.0	345.0	64	+/- 78.9	+/- 3.6
	966578	48.6:1	PREMIUM	7737.1	4349.7	8553.6	38	+/- 3.3	+/- 0.6
			VALUE	2235.6	2235.6	2235.6	10	+/- 12.1	+/- 0.6
32	966638	4:1	PREMIUM	1540.0	874.8	1760.0	430	+/- 26.5	+/- 4.4
	966639	7.25:1	PREMIUM	2791.3	1585.6	3190.0	238	+/- 14.6	+/- 2.4
	966763	37.5:1	PREMIUM	14437.5	8201.3	16500.0	46	+/- 2.8	+/- 0.5
	966778	63.3:1	PREMIUM	24383.3	13851.0	27866.7	28	+/- 1.7	+/- 0.3
40	966791	4:1	PREMIUM	1833.6	1833.6	3667.2	188	+/- 21.0	+/- 3.5
	966549	16.7:1	PREMIUM	7640.0	7640.0	15280.0	45	+/- 5.0	+/- 0.8
4014	966818	3:1	PREMIUM	3743.4	3743.4	5614.8	215	+/- 23.8	+/- 4.0
	966696	5.14:1	PREMIUM	6417.3	6417.3	9625.4	126	+/- 14.0	+/- 2.3
	966725	13.7:1	PREMIUM	17112.7	17112.7	25667.7	47	+/- 5.2	+/- 0.9

Common Attributes for All Gears

Estimated Life	See System Life section.
Operating Temperature Range	°C -5 to 40
Tooth Grease	Part Number 853901



Gear Dimensions & Specifications by Product Number

Figure A

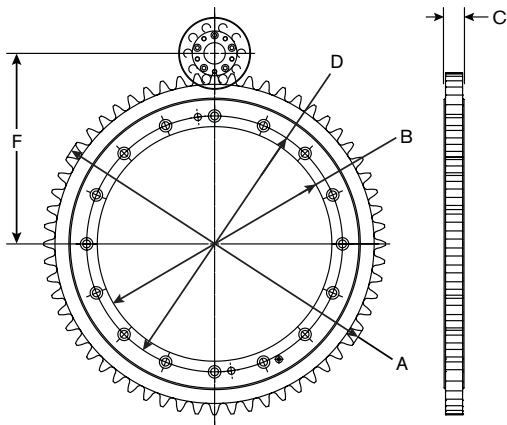

Figure B

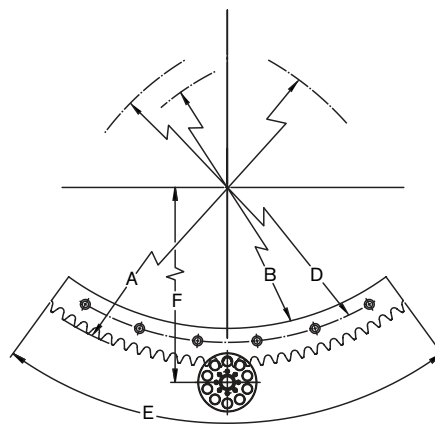
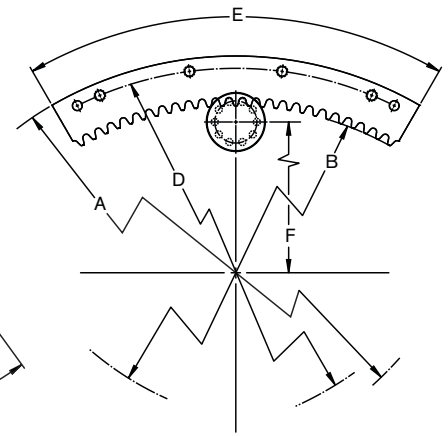

Figure C



Basic gear dimensions shown for selection purposes only and subject to change. Go to www.nexengroup.com for detailed drawings and CAD models. If none of the products below meet your needs, contact Nexen and one can be designed to your specifications. Due to the variety of gears and gear segments, these products are made to order. Please contact Nexen for lead times.

Gear Dimensions & Product Numbers

Dimensions shown in **mm** unless otherwise noted.

RPG Size	Gear Product Number	Alignment Tool Product Number	Teeth Orientation	Number of Teeth	Moment of Inertia	Weight	Figure	Coating	A	B	C	D	E	F
									Outer Diameter	Inner Diameter	Max Width	Bolt Circle Ø	Arc Length/ Full Ring	Distance from Center
16	966566	NA	external	NA/30	0.004	1.2	A	Hard Chrome	161	70	11.5	90	360°/yes	98
	966567	NA	external	NA/40	0.01	1.7	A	Hard Chrome	209	120	11.5	145	360°/yes	122
	966568	NA	external	NA/50	0.03	2.4	A	Hard Chrome	257	160	11.5	180	360°/yes	146
	966569	NA	external	NA/60	0.05	3.4	A	Hard Chrome	305	190	11.5	220	360°/yes	170
	966570	NA	external	NA/70	0.08	3.3	A	Hard Chrome	352	260	11.5	285	360°/yes	193.5
	966797	966557	external	30/150	0.19*	1.6*	B	Hard Chrome	745	652	11.5	670	72°/yes	390
	966571	966656	external	25/400	1.64*	1.8*	B	Hard Chrome	1954	1830	11.5	1870	22.5°/yes	995
20	966572	966706	external	28/140	0.48*	2.9*	B	Hard Chrome	880	770	15.5	810	72°/yes	462
	966798	966615	internal	25/150	0.86*	3.6*	C	Hard Chrome	1038	906	15.5	1013	60°/yes	430
	966799	966734	external	30/180	0.76*	2.7*	B	Hard Chrome	1120	1020	15.5	1060	60°/yes	582
	966793	966794	external	30/540	9.57*	3.6*	B	Hard Chrome	3338	3220	15.5	3250	20°/yes	1692
	966789	966790	internal	19/684	14.9*	3.2*	C	Hard Chrome	4400	4241	15.5	4354	10°/yes	2098
	966787	966788	external	30/900	36.3*	4.9*	B	Hard Chrome	5554	5392	15.5	5438	12°/yes	2800
25	966573	NA	external	NA/30	0.04	4.5	A	Hard Chrome	254	120	18.5	145	360°/yes	154
	966574	NA	external	NA/40	0.12	6.8	A	Hard Chrome	331	190	18.5	220	360°/yes	193
	966575	NA	external	NA/50	0.25	9.1	A	Hard Chrome	404	260	18.5	285	360°/yes	230
	966576	NA	external	NA/60	0.47	11.5	A	Hard Chrome	480	330	18.5	360	360°/yes	268
	966577	NA	external	NA/75	0.93	13.5	A	Hard Chrome	596	460	22.5	490	360°/yes	326
	966578	966740	external	27/486	15.7*	4.6*	B	Hard Chrome	3760	3640	18.5	3684	20°/yes	1908
32	966638	NA	external	NA/48	0.69	16.6	A	Hard Chrome	493	330	24.5	360	360°/yes	292
	966639	NA	external	NA/87	4.4	27.8	A	Black Oxide	874	730	24.5	770	360°/yes	482
	966763	966685	external	18/450	35.7*	7.7*	B	Hard Chrome	4400	4220	24.5	4280	14.4°/yes	2246
	966778	966779	external	19/760	112.8*	8.4*	B	Hard Chrome	7428	7250	24.5	7310	9°/yes	3760
40	966791	NA	external	NA/48	2.5	39.2	A	Hard Chrome	622	390	35.5	430	360°/yes	369
	966549	966546	external	11/200	9.1*	6.4*	B	Hard Chrome	2482	2320	31.5	2360	19.8°/no	1300
4014	966818	NA	external	NA/42	1.69	31.5	A	Hard Chrome	551	390	46	430	360°/yes	346
	966696	966547	external	18/72	2.82*	17.3*	B	Hard Chrome	916	711.2	42	785	90°/yes	529
	966725	966548	external	12/192	12.5*	9.4*	B	Hard Chrome	2392	2230	42	2270	22.5°/yes	1268

* Per Segment



RPS ROLLER PINION

Once you have selected your rack/gear, finding the right pinion is easy. The following pages offer step-by-step selection instructions as well as pinion specifications and details on accessories.

Pinion Selection Process	22
Specifications	22
Dimensional Drawings	23–26
Pinion Accessories	

Adapters	27
----------------	----

Preloaders	27–29
------------------	-------



PATENTED



RPS Pinion Selection Process

STEP 1: Determine your rack/gear size and find the same RPS pinion size. Always use the same size rack/gear and pinion.

STEP 2: Select the material best suited for your application. (Other materials available upon request.)

Hard Chrome: alloy steel with a thin, dense chrome coating

Nickel: alloy steel with nickel plating

Stainless: stainless steel with or without a hard chrome coating

STEP 3: Select Mounting Style: For easy installation and maximum versatility, Nexen recommends using the flange-mounted version when practical.

Shaft Mount

- Shaft Coupling or Shaft & Keyway mounting option
- Coupling option uses a keyless mechanical compression coupling to secure to shaft
- Available in multiple bore diameters. Contact Nexen.

Flange Mount

- Conforms to ISO 9409 specifications
- Nexen adapter preloader options available with this version

Pinion Selection

Pinion Type	RPS Size	Number of Rollers	Distance per Revolution	Pitch Circle Diameter	Max RPM *	Product Number	Base Material/Coating	Mount Style	Bore Size	Mass	Moment of Inertia
			mm	mm					mm		kg
PREMIUM PINIONS	10	10	100	31.8	2400	966480	Hard Chrome	Shaft Coupling	12	0.2	0.4
	12	10	120	38.2	4000	966490	Hard Chrome	Shaft Coupling	16	0.3	1.0
	16	10	160	50.9	1500	966819	Nickel	Shaft Coupling	16	0.7	3.9
						966650	Nickel	Shaft Coupling	20	0.7	3.9
						966761	Stainless	Shaft Coupling	20	0.7	3.9
						966687	Nickel	Flange	N/A	0.8	4.0
						966759	Stainless	Flange	N/A	0.8	4.0
						Request	Stainless	Flange	N/A	0.8	4.0
	20	10	200	63.7	1500	966820	Nickel	Shaft Coupling	22	1.4	10.6
						966660	Nickel	Shaft Coupling	25	1.3	10.5
						966771	Stainless	Shaft Coupling	25	1.3	10.5
						966675	Nickel	Flange	N/A	1.2	10.2
						Request	Stainless	Flange	N/A	1.2	10.2
	25	10	250	79.6	1820	966670	Nickel	Shaft Coupling	30	2.1	25.5
						966758	Stainless	Shaft Coupling	30	2.1	25.2
						966673	Nickel	Flange	N/A	2.1	25.2
						Request	Stainless	Flange	N/A	2.1	25.2
	32	12	384	122.2	1719	966821	Nickel	Shaft Coupling	32	7.3	173.0
						966822	Nickel	Shaft Coupling	40	6.8	171.0
						966680	Nickel	Shaft Coupling	45	6.4	169.0
						Request	Stainless	Shaft Coupling	45	6.4	169.0
						966677	Nickel	Flange	N/A	6.6	168.0
						Request	Stainless	Flange	N/A	6.6	168.0
	40	12	480	152.8	750	966823	Nickel	Shaft Coupling	55	12.9	598.0
						966690	Nickel	Shaft Coupling	60	12.4	594.0
						Request	Stainless	Shaft Coupling	60	12.4	594.0
						966697	Nickel	Flange	N/A	15.5	665.0
						Request	Stainless	Flange	N/A	15.5	665.0
4014	14	560	178.3	643	966824	Nickel	Shaft Coupling	55	21.4	1184.0	
					966693	Nickel	Shaft Coupling	60	20.9	1180.0	
					Request	Stainless	Shaft Coupling	60	20.9	1180.0	
					966700	Nickel	Flange	N/A	23.5	1306.0	
					Request	Stainless	Flange	N/A	23.5	1306.0	
VALUE PINIONS	16	10	160	50.9	750	966826	Aluminum	Shaft & Keyway	16	0.4	2.4
	20	10	200	63.7	600	966827	Aluminum	Shaft & Keyway	16	0.7	6.0
	25	10	250	79.6	480	966828	Aluminum	Shaft & Keyway	22	1.1	14.7

* The maximum rated speed of a RPS system is equal to the lowest rating of either the pinion or the rack.

See the **Definitions** section for more information on these attributes.

Common Attributes for All Pinions

Estimated Life	See <i>System Life</i> section.	
Operating Temperature Range	°C	-5 to 40
Lubrication/Tooth Grease	Part Number 853901	

Pinion Dimensions

ADDITIONAL DIMENSIONS

The Pinion dimensions listed here are for selection purposes only. For detailed drawings and CAD models, please visit www.nexengroup.com.

PINION ADAPTERS

Pinion adapters allow the pinion to mount to one frame-size larger of a reducer. Moving up a reducer size is sometimes needed due to reducer availability or motor sizing reasons. All Nexen pinion adapters are made from corrosion resistant materials or coatings. For your convenience, we have included pinion adapter dimensions next to each ISO9409 flange mounted pinion. See Table 6 for pinion adapter part numbers.

RPS10 Premium Pinion

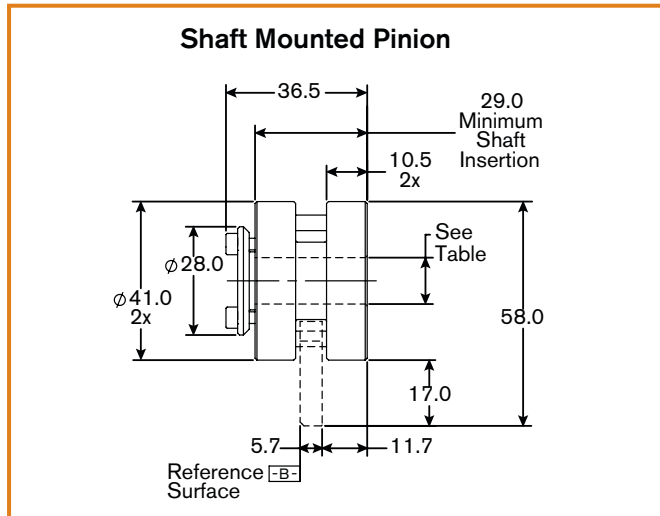

RPS12 Premium Pinion

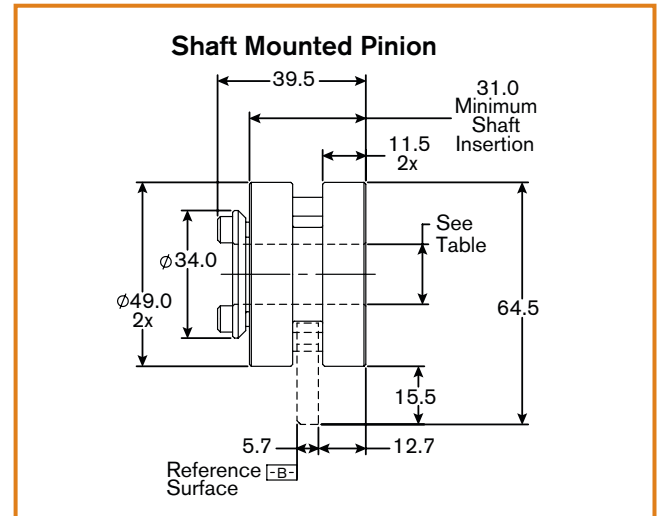

Pinion Dimensions

RPS16 Premium Pinion

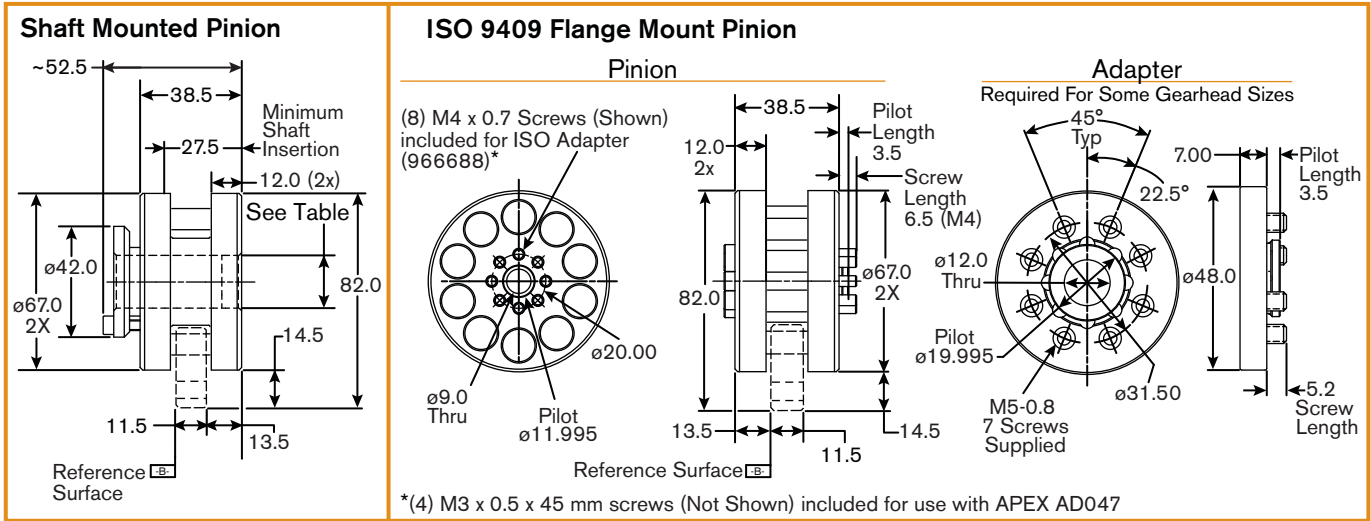

RPS16 Value Pinion

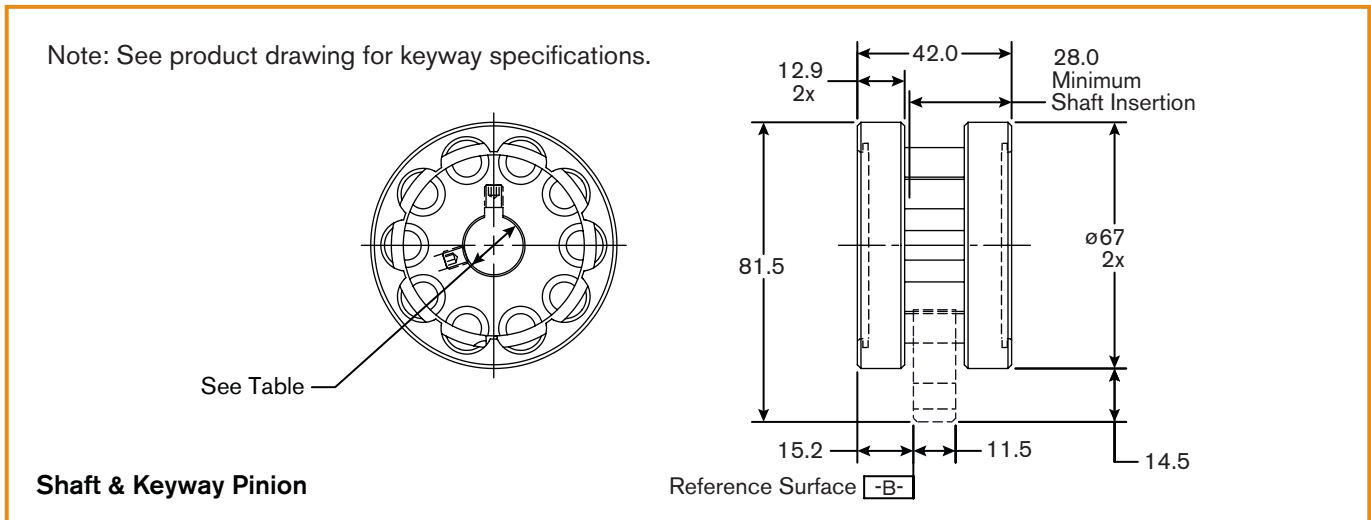

RPS20 Premium Pinion

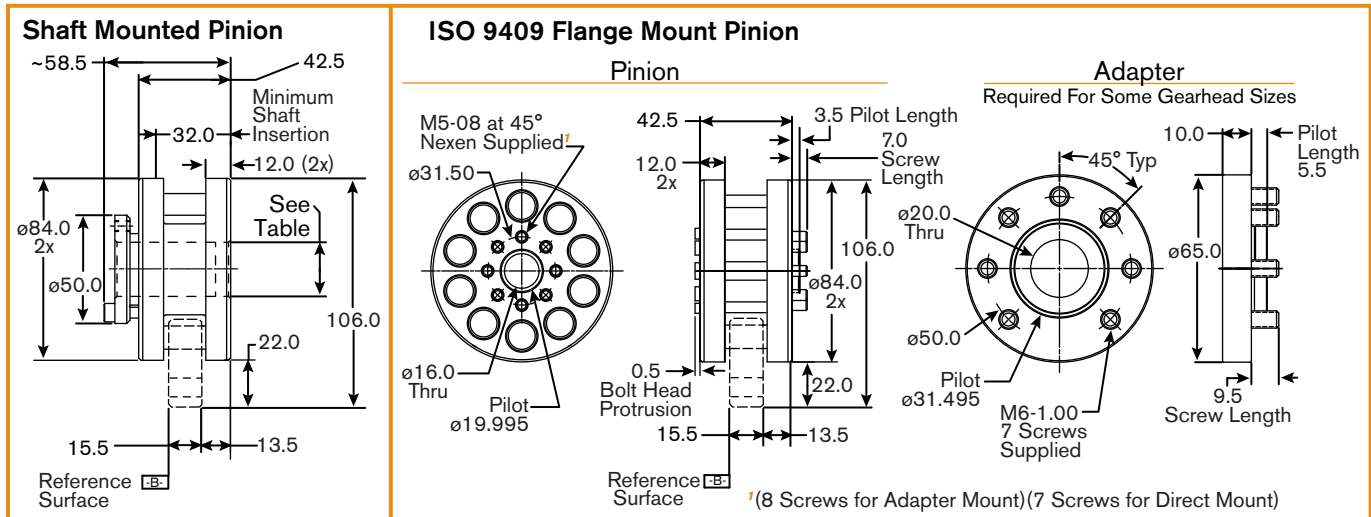

Pinion Dimensions

RPS20 Value Pinion

Note: See product drawing for keyway specifications.

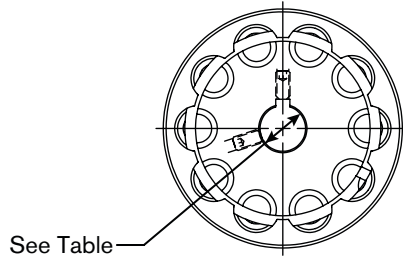

See Table

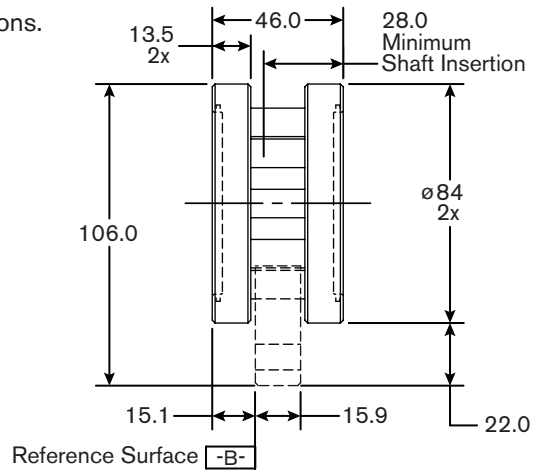

Shaft & Keyway Pinion

RPS25 Premium Pinion

Shaft Mounted Pinion

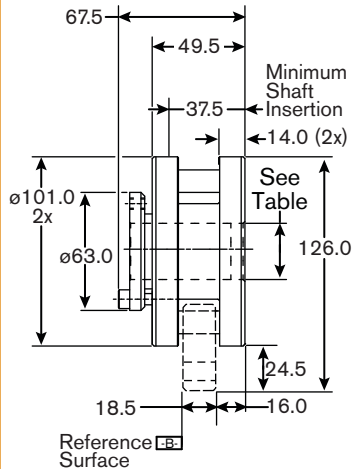

ISO 9409 Flange Mount Pinion

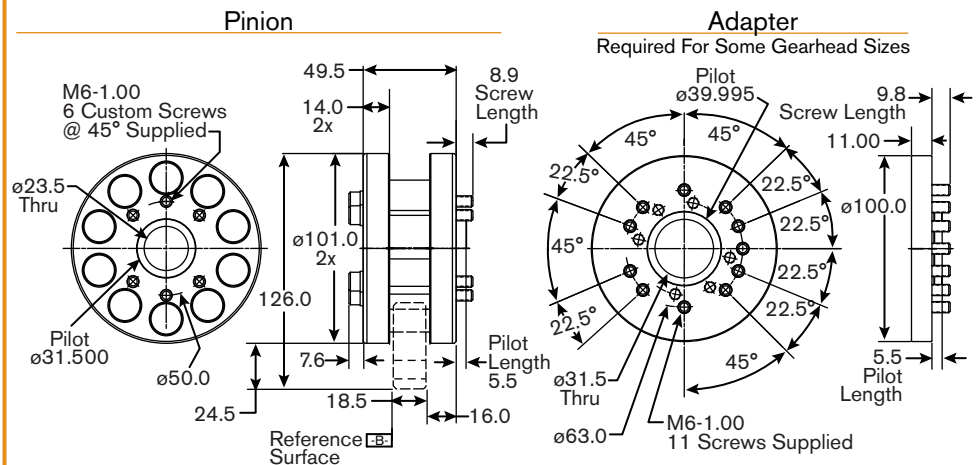

RPS25 Value Pinion

Note: See product drawing for keyway specifications.

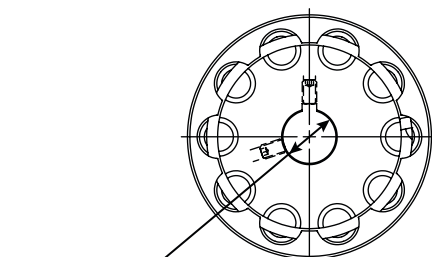

See Table

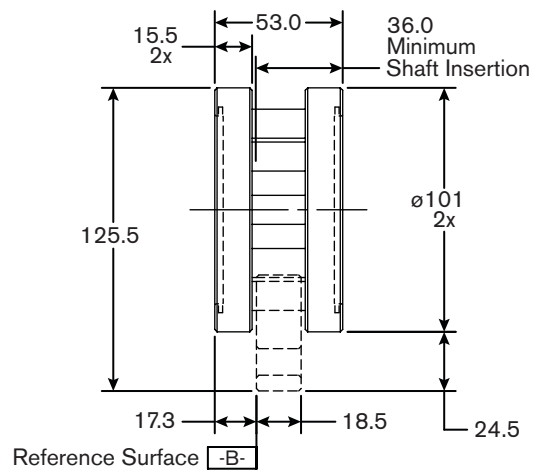

Shaft & Keyway Pinion

Pinion Dimensions

RPS32 Premium Pinion

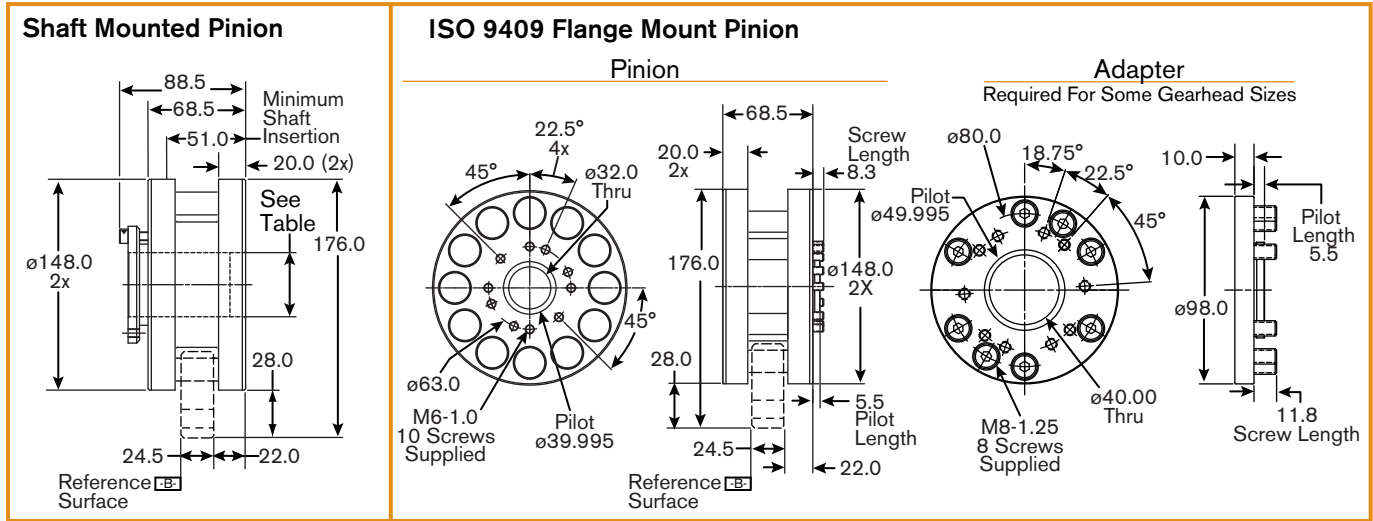

RPS40 Premium Pinion

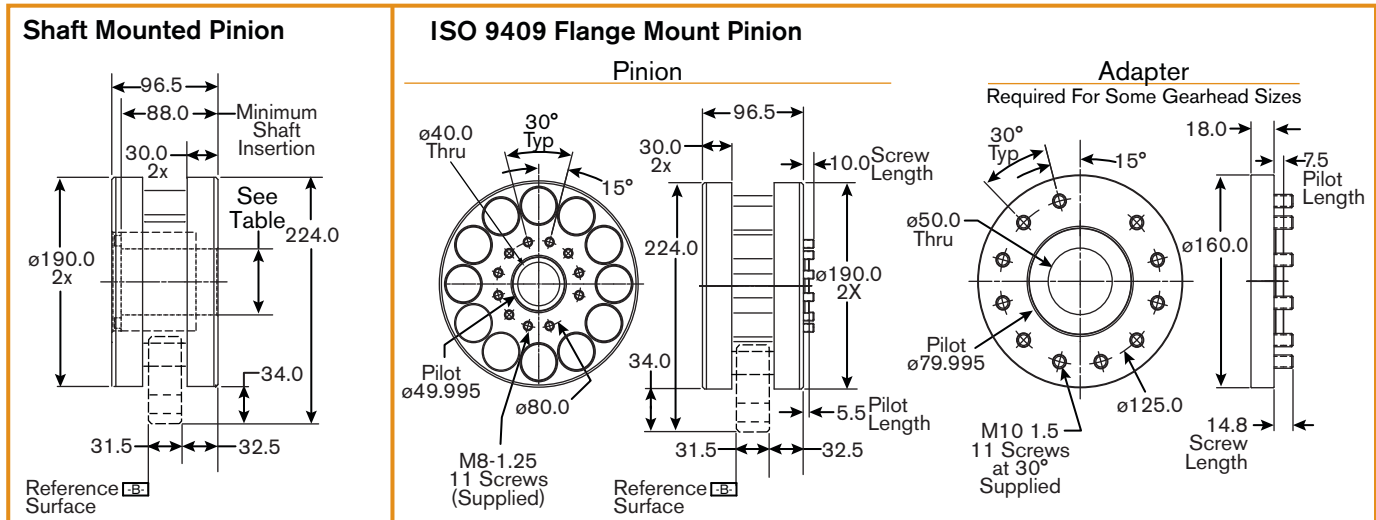

RPS4014 Premium Pinion

