

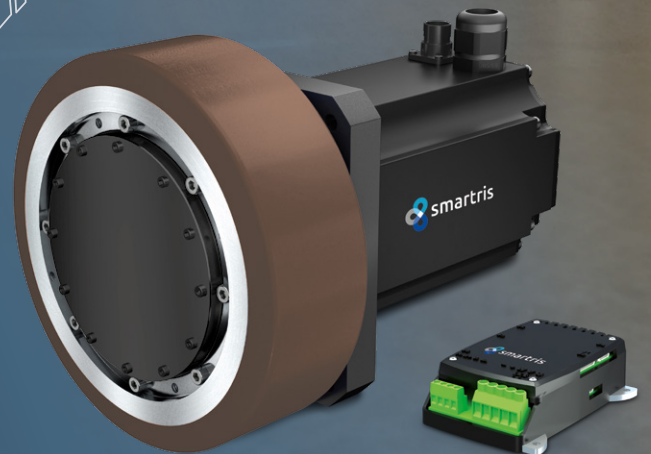

smartris
solutions for AGV/AMR

Packaged-Drive System Solution

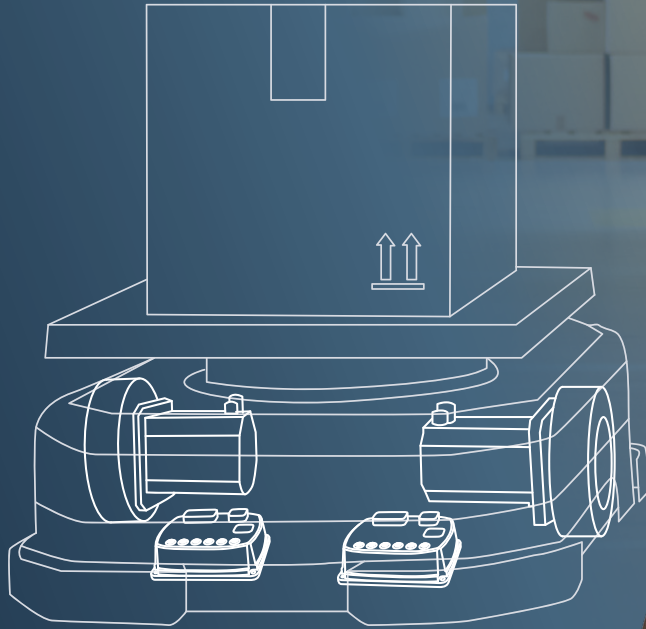

Sumitomo Drive Technologies

LAFERTGROUP
Member of Sumitomo Drive Technologies

www.smartris.com



Benefits

- Complete Package Solution:
Gear + Servo Motor + Drive + Wheel
- High integration of all components
- One single supplier with global presence
- **Compact solution**
- Safety features
- Easy installation and commissioning
- Maintenance free
- **Customizations** available on request

The range

- Total weight up to approx. 3.000 kg
- Max speed 2.0 m/s
- Max acceleration 1.0 m/s²

Target Applications

- Unit Load Carriers
- Tow Vehicles
- Assembly Line Trucks
- Mobile Robots

Suitable for shuttle horizontal AGV configuration with electronic differential drive system.

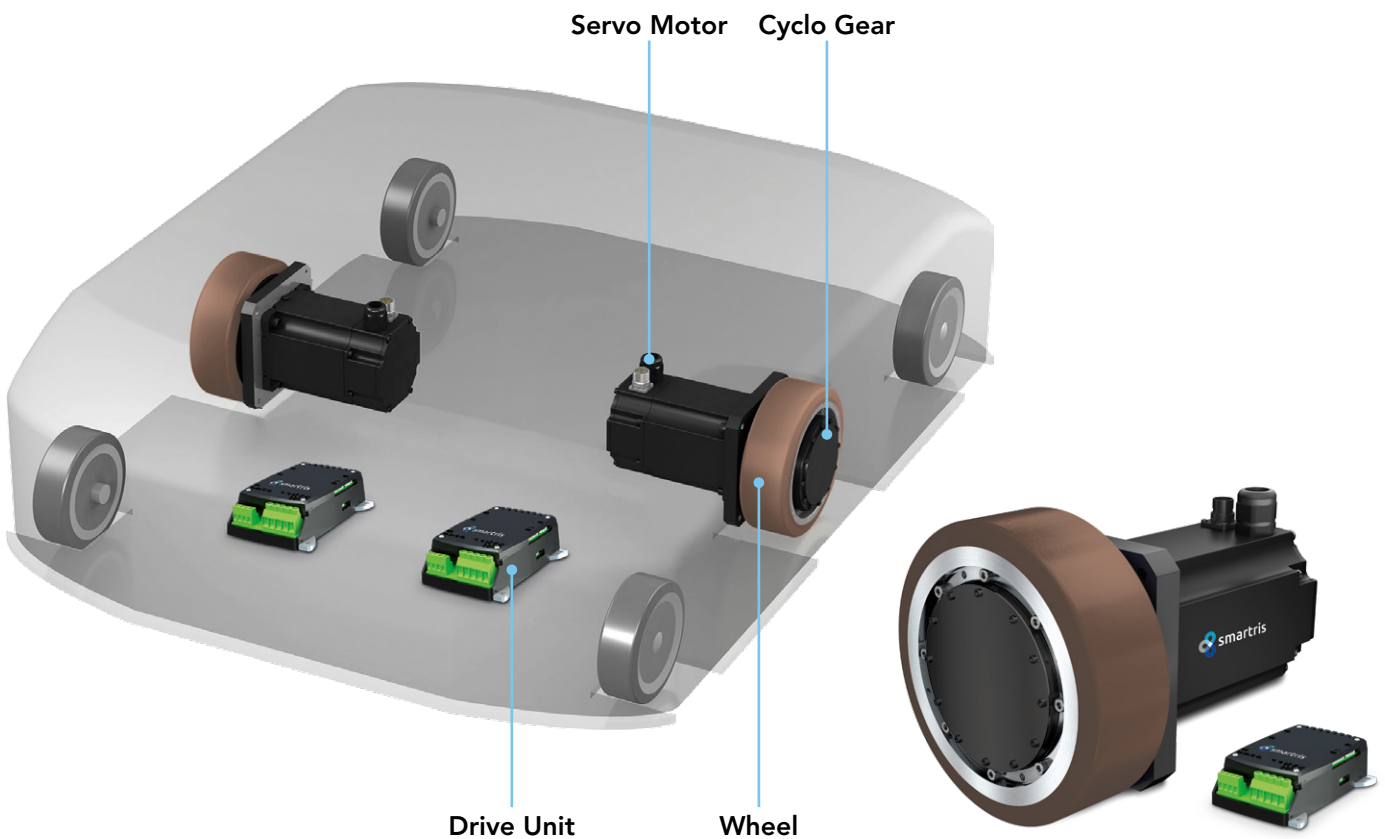

Two Product Lines to satisfy Customer Needs

ECO LINE

- Gear Output Shaft Rotation Design
- Cost efficient solution
- Ideal for light payloads and high-speed AGV

PRO LINE

- Ring Gear Housing Rotation Design
- High radial loads
- Reduced overall dimension

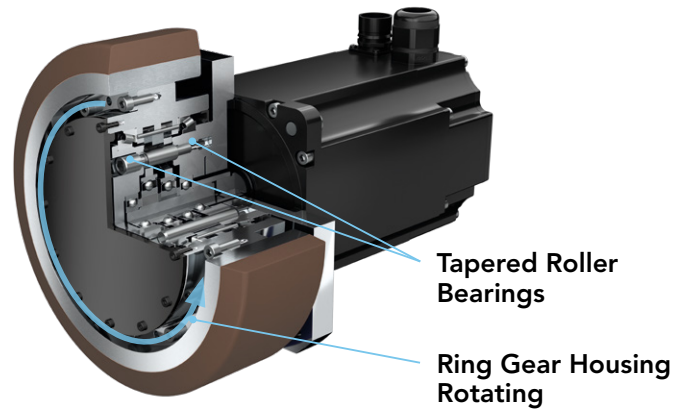
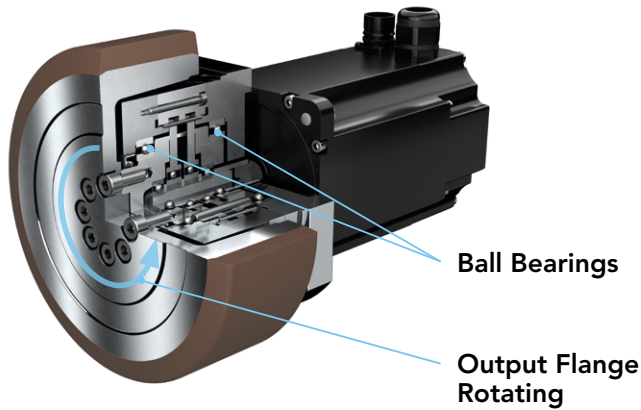

Gearmotor Performances

		ECO		PRO	
		S	M	M	L
Voltage	[Vdc]	48	48	48	48
Max Radial Load per Driving Wheel	[N]	1500	3000	6500	10000
Gear Ratio		21 - 25 - 29	21 - 25 - 29	22 - 26	22 - 26 - 30
Max Motor Speed	[rpm]	4500	4500	4500	3000
Max Wheel Speed	[rpm]	214 - 180 - 155	214 - 180 - 155	205 - 173	136 - 115 - 100
Nominal Wheel Torque	[Nm]	16 - 18.9 - 18.9	39.3 - 40.4 - 40.5	39.3 - 40.4	84.7 - 87.5 - 80.3
Max Acceleration Wheel Torque for 2 sec	[Nm]	61.9 - 73.7 - 84.8	145 - 179 - 207	145 - 179	312 - 365 - 246
Minimum Holding Torque (Static Brake)	[Nm]	76 - 91 - 105	191 - 227 - 264	200 - 236	200 - 236 - 276
Minimum Holding Torque (Dynamic Brake)	[Nm]	33 - 40 - 46	191 - 227 - 264	200 - 236	200 - 236 - 276
Ambient Temperature	[°C]	-10 ÷ 40		-10 ÷ 40	
Protection Class		IP54		IP54	
Thermal Motor Class		F		F	
Rotation Type		Gear Output Shaft Rotation		Ring Gear Housing Rotation	

Example of AGV Configuration

		ECO		PRO	
		S	M	M	L
Max Tot Weight (AGV mass + payload)	[kg]	800	1100	1800	2700
No. of Driving Wheels		2	2	2	2
No. of Supporting Wheels		4	4	4	4
Max AGV Speed	[m/s]	2	2	2	1.8
Max AGV Acceleration	[m/s ²]	1	1	1	1
Wheel Diameter	[mm]	180	200	200	250
Gear Ratio		21	21	22	22
Nominal Wheel Speed	[rpm]	212	191	191	136
Average Wheel Torque	[Nm]	14.1	21.6	35.3	66.2
Average Wheel Power	[W]	314	432	706	943
Load Bearing per Supporting Wheel	[kg]	125	125	125	175

Dimensions - ECO LINE

GEARMOTOR

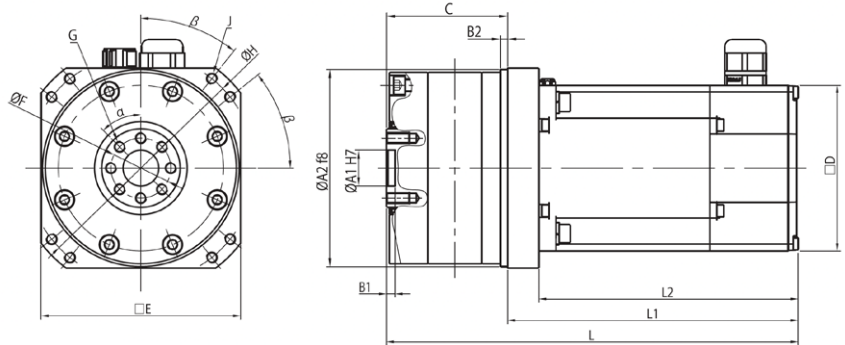
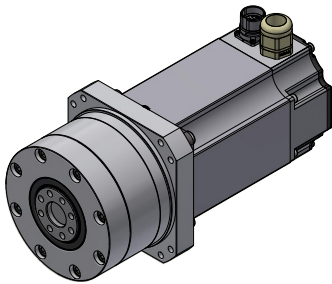

Line	Size	ØA1 [mm]	ØA2 [mm]	B1 [mm]	B2 [mm]	C [mm]	□D [mm]	□E [mm]	ØF [mm]	G [mm]	ØH [mm]	J [mm]	α°	β°	Mass [Kg]
ECO	S	25	110	6	4	76	80	110	35	10-M6	130	4-M8	36	45	5.6
ECO	M	25	138	6	5	85	116	140	42	8-M8	160	8-M8	45	38.5	11.3

Dimensions above refer to standard design. For special design, please contact us.

Line	Size	TRANSDUCER	BRAKE	L [mm]	L1 [mm]	L2 [mm]
ECO	S	RESOLVER	STATIC	235	159	143
		RESOLVER	DYNAMIC	234	158	142
		SKS36S	STATIC	249	173	157
		SKS36S	DYNAMIC	248	172	156
ECO	M	RESOLVER	STATIC	288.5	203.5	181.5
		RESOLVER	DYNAMIC	298.5	213.5	191.5
		SKS36S	STATIC	288.5	203.5	181.5
		SKS36S	DYNAMIC	298.5	213.5	191.5

WHEEL MOTOR

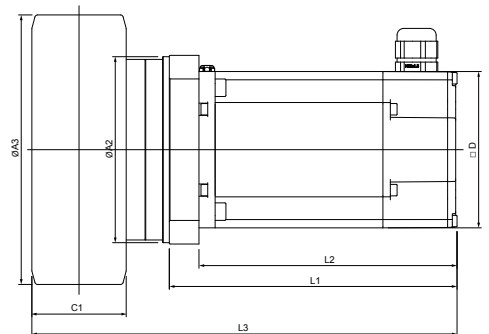
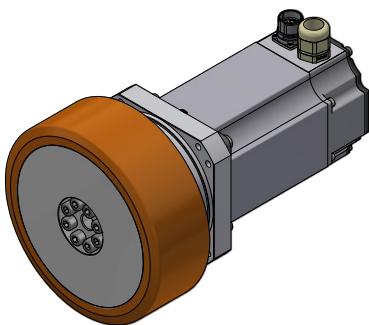

Line	Size	L3 [mm]	WHEEL DIAMETER ØA3 [mm]	WHEEL WIDTH C1 [mm]
ECO	S	L + 14.5	180	65
ECO	M	L + 17	200	70

Dimensions – PRO Line

GEARMOTOR

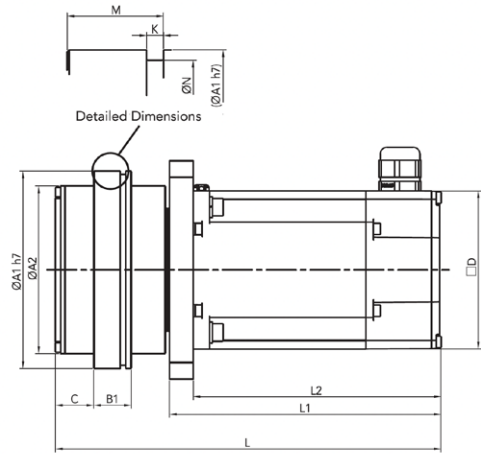
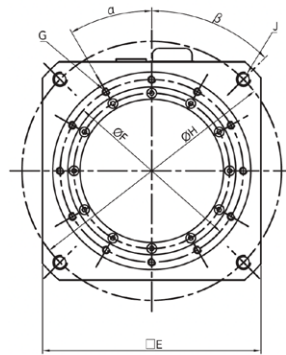
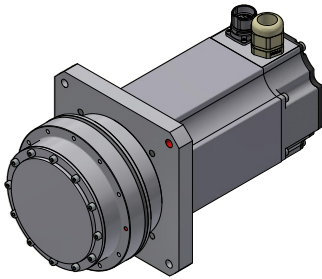

Line	Size	ØA1 [mm]	ØA2 [mm]	B1 [mm]	C [mm]	□D [mm]	□E [mm]	ØF [mm]	G [mm]	ØH [mm]	J [mm]	K [mm]	ØN [mm]	M [mm]	α°	β°	Mass [Kg]
PRO	M	145	123	27.5	28	116	160	134	12-M5	190	4-M10	4.1	140	23.5	30	45	14.5
PRO	L	182	155	38	30	142	196	170	12-M6	230	4-M12	4.78	175.8	32.8	30	45	24.5

Dimensions above refer to standard design. For special design, please contact us.

To prevent fretting corrosion on wheel rim and ring gear housing (just for PRO gears), is recommended to apply molybdenum disulfide grease (or similar agent). Customer needs to apply this agent.
To prevent anti corrosion grease leakage, is recommended to apply O-Ring on proper ring gear housing (just on PRO gears). Customer needs to provide and apply O-Ring.

Size	O-ring (Nitrile Rubber) Wire Diameter x Inner Diameter
M	3.1x139.4
L	3.53x171.04

Line	Size	TRANSDUCER	BRAKE	L [mm]	L1 [mm]	L2 [mm]
PRO	M	RESOLVER	STATIC	282.5	198.8	181.5
		RESOLVER	DYNAMIC	292.5	208.8	191.5
		SKS36S	STATIC	282.5	198.8	181.5
		SKS36S	DYNAMIC	292.5	208.8	191.5
PRO	L	RESOLVER	STATIC	299.1	202.6	185.3
		RESOLVER	DYNAMIC	305.6	209.1	191.8
		SKS36S	STATIC	309.3	212.8	195.5
		SKS36S	DYNAMIC	315.8	219.3	202

WHEEL MOTOR

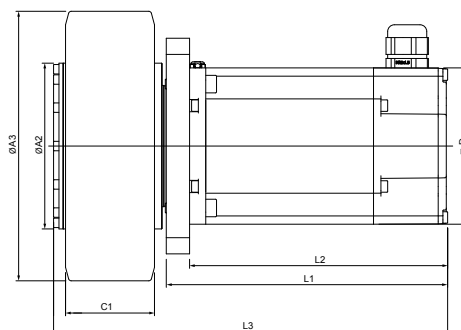
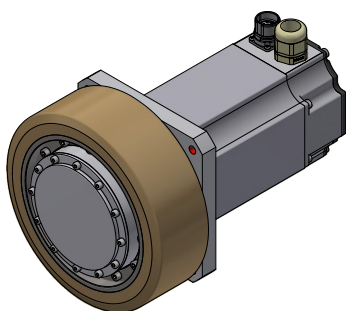

Line	Size	L3 [mm]	WHEEL DIAMETER ØA3 [mm]	WHEEL WIDTH C1 [mm]
PRO	M	L + 0	200	66
PRO	L	L + 0	250	75

Drive Performances

- Easy installation without additional PID tuning
- Easy to install with state machine profile suitable for all AGVs
- Specifically designed for prompt reaction in case of AGV emergency quick stop
- NEW Smartris Compact Drive for sizes S - M: a quarter of the size of the Smartris Drive

	ECO		PRO	
	S	M	M	L
Smartris Drive	✓	✓	✓	✓
Smartris Compact Drive	✓	✓	✓	-

Size		ECO		PRO	
		SMALL	MEDIUM	MEDIUM	LARGE
Voltage	[Arms]	48V (60V Max)		48V (60V Max)	
Rated Current	[Arms]	12.5	25.8	25.8	35.8
Peak Current for 2 sec	[Arms]	41	96.3	96.3	136.2
Peak Current for 10 sec	[Arms]	24.9	57.5	57.5	81.3

SMARTRIS DRIVE - IP 54

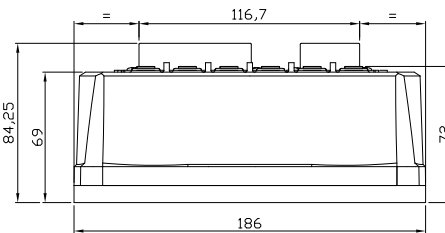
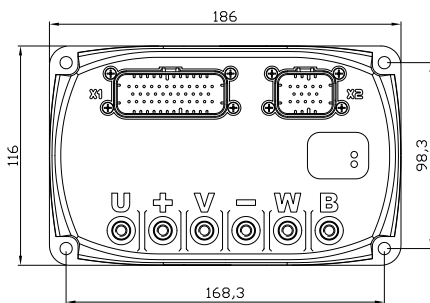

Weight 1.6 kg



SMARTRIS COMPACT DRIVE - IP 20

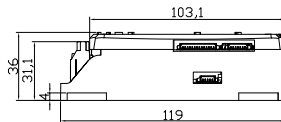
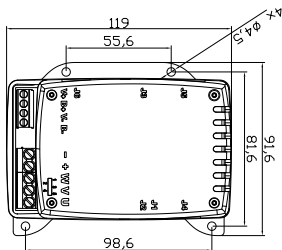

Weight 310 gr



Drive Specifications

Transducer	Sin/Cos Encoder - Resolver
Fieldbus	CANOpen (DS402), Modbus RTU
Control Mode	Torque, Speed and Position*
Brake Management	Manual or Automatic
Auxiliary power supply for control stage	Available (24 or 48 Vdc)
Digital Output	4 Output Optical Isolated @ 24V - 100mA
Digital Input	4 Input Optical Isolated @ 24V - 7mA (NPN or PNP type)
Analog Input	1 Input \pm 10V or Single ended 0-10V (10 K Ω)
Analog Output	1 Output 0-10V R _{LOAD} \geq 1 K Ω
Safety Feature	STO (24Vdc - 29mA) Smartris Compact drive SIL2(IEC 61800-5-2)/PLd(EN 13849-1) Smartris drive SIL3(IEC 61800-5-2)//PLe(EN 13849-1)
Options	Heatsink
Certification	CE, UL

* Position control under development

Up-to-date data, along with dimensional drawings and 3D models, available at www.smartris.com

Feedback Cables

Feedback cables connect motor transducer directly to our Smartris Drives.

Main Features:

- Insulating material: PVC/PUR
- Shielded and Twisted in pair
- Extra flexible

FOR SMARTRIS DRIVE

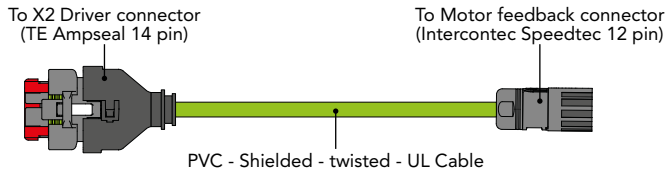

FOR SMARTRIS COMPACT DRIVE

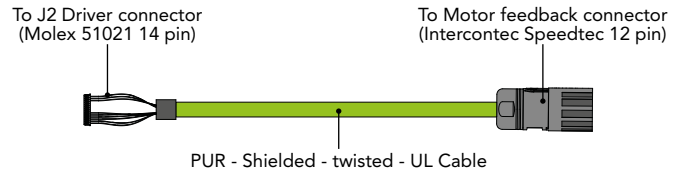

Y-CABLE

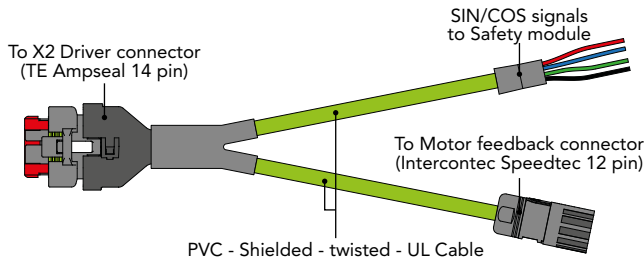

Y-cable is meant to split our safety encoder Sin/Cos signals both to our drive and Safety module in order to achieve highest safety level without using any additional encoder in the vehicle.

Wheels Specifications

Line	Size	WHEEL DIMENSION [mm]	TYRE MATERIAL	RIM MATERIAL	MAX SPEED [Km/h]	MAX RADIAL LOAD [N]	MASS [Kg]
ECO	S	180x65	Polyurethane 92ShA	Steel	8	1500	3.7
ECO	M	200x70	Polyurethane 92ShA	Steel	8	3000	5.2
PRO	M	200x66	Polyurethane HP 93ShA	Steel	8	6500	2.7
PRO	L	250x75	Polyurethane HP 93ShA	Steel	6.5	10000	6.4

Wheels are suitable for tiles and cement-resin. Use on other kind of floors has to be confirmed by manufacturer. Wheels are not suitable if large obstacles are present. Operating temperature range 0-40°C. Recommended for use in environments without condensation accumulation.

Mounting

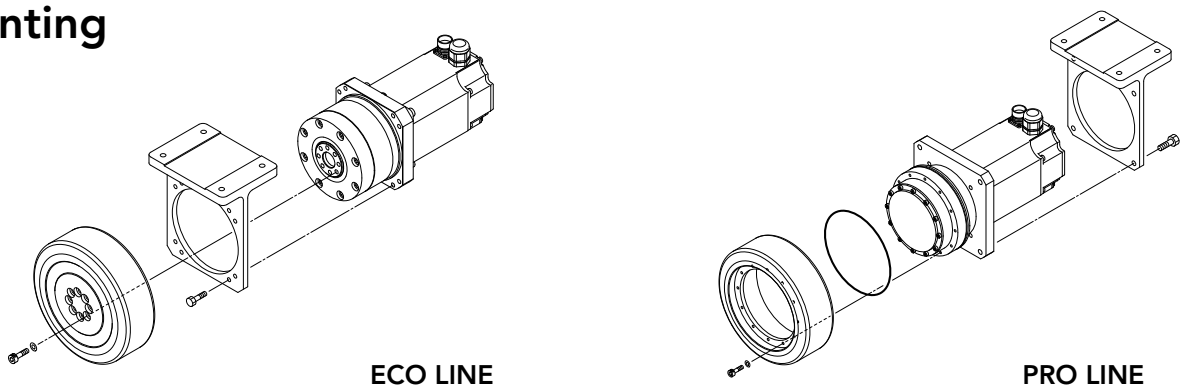

Sumitomo Drive Technologies

Sumitomo (SHI) Cyclo Drive Germany GmbH
Cyclostraße, 92 – 85229 Markt Indersdorf, Germany
Tel. +49 8136 660
scg.info@shi-g.com - www.sumitomodrive.com



Lafert S.p.A.
Via J.F. Kennedy 43 – 30027 – San Donà di Piave (Venice), Italy
Tel +39 0421 229 611
lafert.info@shi-g.com - www.lafert.com